

MODEL

- GK26 - 1
- GK26 - 2
- GK26 - 1A
- GK26 - 2A
- GK26 - 1H

PORTABLE FILLED BAG CLOSING MACHINE

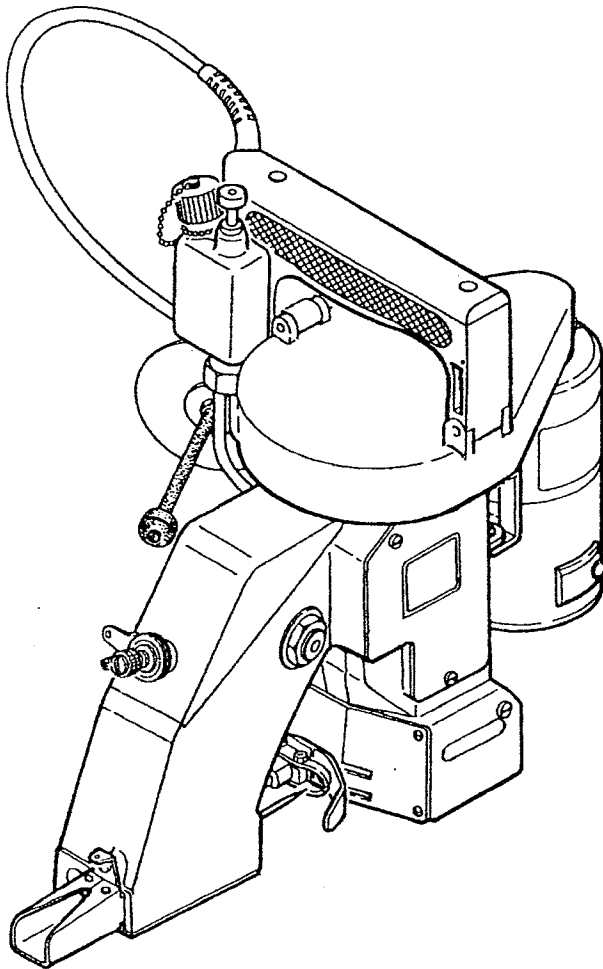

INSTRUCTION MANUAL/PARTS LIST

CONTENS

1. SPECIFICATIONS	1
2. PREPARATION FOR START	2
1. Oiling	2
2. Needle Setting	2
3. Threading	2
3. START	3
4. ADJUSTMENTS	4
4-1. Thread Tension	4
4-2. Position of Needle and Looper	4
4-3. Position of Feed Dog	4
4-4. Pressure of Presser Foot	4
4-5. For Replacement or Adjustment of Ball Rod	4
5. LUBRICATOR	5
6. MAINTENANCE	6
7. ORDERING PARTS	7

1. SPECIFICATIONS

TECHNICAL DETAILS

1. Seam	Single Thread Chain Stitch
2. Stitch Range(mm)	6.5(fixed)
3. Revolution(rpm)	1250
4. Needle	DN×1#25
5. Thread(vinylon, synthetic or cotton)	20/6
6. Bag Material To Be Closed	Kraft Paper, pp/PE, Woven cloth, Cotton, Hessian, Jute
7. Drive Motor	90W
8. Power Supply	110,220 or 240V, A. C.
9. Net Weight(Kg)	5.9Kg
10. Machine Dimension(mm)	
GK26 - 1, GK26 - 1A	275mmW, 370mmL, 305mmH
GK26 - 2, GK26 - 2A	320mmW, 370mmL, 305mmH

STANDARD ACCESSORIES

1. Needles DN×1#25	10pcs
2. Thread Vinylon 20/6	1roll
3. Timing Belt	1pcs
4. Looper	1pcs
5. Motor Brushes	2pcs
6. Screw Driver	1pcs
7. Forceps	1pcs
8. Hex Wrench	1pcs
9. Oiler	1pcs

2. PREPARATION FOR START

1. Oiling(Fig. 1)

Oiling is imperative to keep the machine in good operating condition. Pour oil in the reservoir (capacity 45 cc). To begin the flow of oil to the machine, push the button of the lubricator ten times continuously before starting the machine. This should dispense enough oil for an average running of four hours under normal operating conditions. Do not run the machine without oil as it could causes a machine failure or break down.

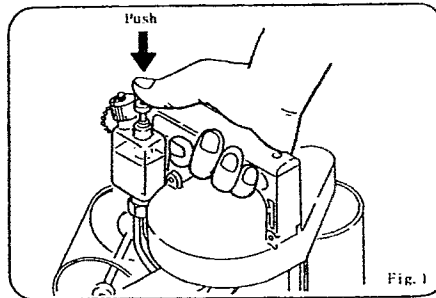

2. Needle Setting (Fig. 2,3,4)

Turn the pulley until Needle Bar reaches its highest position. Loosen Needle Bar Clamping Nut, and set Needle in the Bar as deep as it will go. Be sure to set a Needle with its concave part facing correctly toward the Loper. Fix Clamping Nut tightly, otherwise Needle may come loose during operation and break.

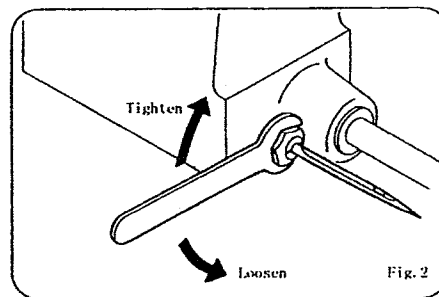

3. Threading(Fig. 5)

The machine is delivered being threaded to show you proper threading of the machine, which is shown in Fig. 5, for identification. Follow the guide numbers 1 to 7 of Fig. 5.

- | | |
|-----------------|-----------------|
| ① Thread Eyelet | ⑤ Needle Bar |
| ② Tension Disc | ⑥ Thread Eyelet |
| ③ Thread Eyelet | ⑦ Needle |
| ④ Thread Eyelet | |

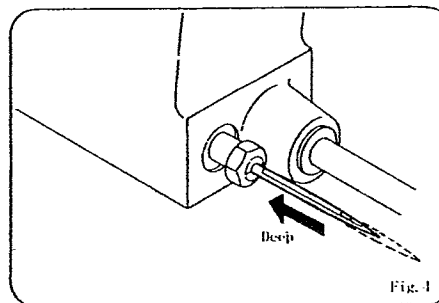
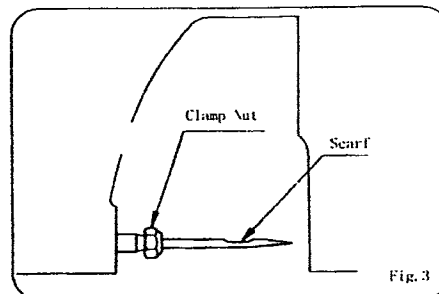
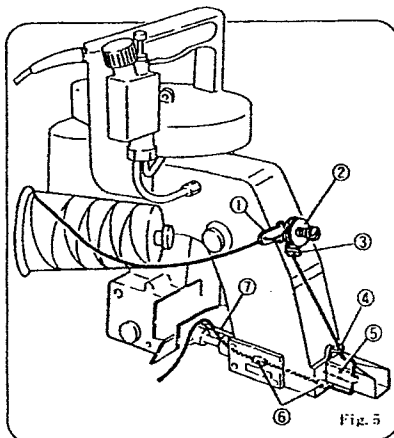

3. START

Before starting, make sure that the supply voltage accords with the specification of the motor.

Hold the machine in your right hand and place your index finger on the switch button on the handle. (Fig. 6)

Hold the bag in your left lightly and insert the bag mouth between Feed Dog and Presser Foot. (Fig. 7)

7)

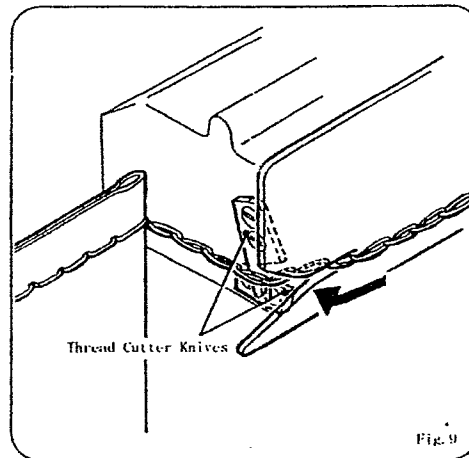
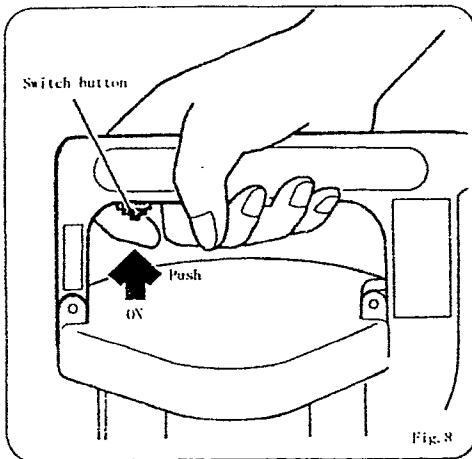
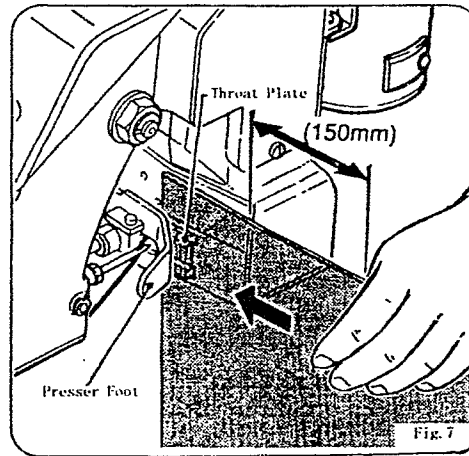
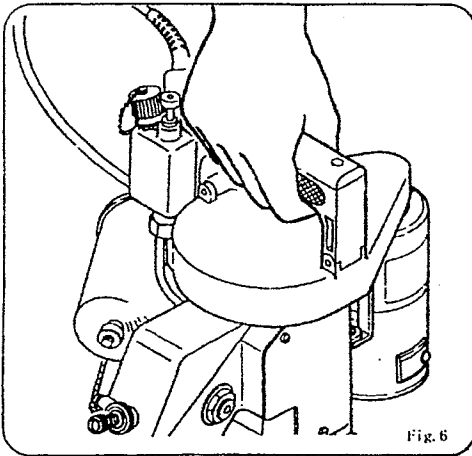

Run the machine while keeping the bag straight. Never pull or pull back the bag.

After closing, the thread is cut by the built-in nibbler type cutter.

When cutting the thread, leave at least 3 cm long extended tail to prevent the unwilling loosening of the seam. (Fig. 9)

Run the machine with empty bags and make sure you are well versed in its operation before entering into actual operation.

4. ADJUSTMENTS

Important!

When adjusting the machine or replacing parts, always disconnect the Electric Cord from the power source.

This is important in view of safety to the operator and adjuster.

4 - 1. Thread Tension

Thread Tension is adjustable by turning the Thread Tension Nut.

Turn the Nut clockwise for tighter tension and counter - clockwise for looser.

4 - 2. Position of Needle and Loper(Fig. 10)

Looper must pass the concave part of Needle with clearance of 0.1 mm as shown in Fig. 10.

Adjustment of the clearance can be done after loosening the screw of Loper Rocker.

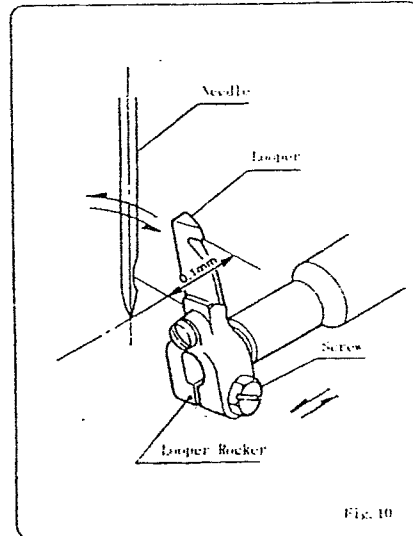

Fig. 10

4 - 3. Position of Feed Dog

When installing a new feed dog ensure that it is positioned correctly onto the feed dog carrier block and lightly tighten the fixing screw. Check that the feed dog teeth are 2.8mm above the throat plate when the feed dog is in the highest position before final tightening of the fixing screw.

4 - 4. Pressure of Presser Foot

When to adjust the pressure of Presser Foot, take out Needle Bar Guard and loosen Screw of Presser Bar Connection. Move up Presser Bar to increase the pressure and down to decrease. After the adjustment, tighten the Screw firmly.

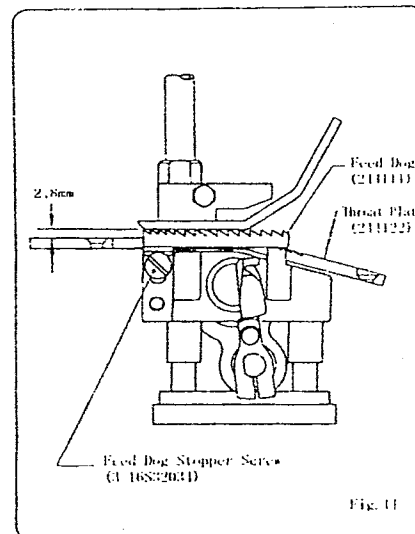

Fig. 11

4-5. For replacement or adjustment of Ball Rod, refer to Fig. 12.

Take out Screw ① and disconnect Rod End ② from Needle Bar Lever ③. After loosening the Nut ④, adjust the clearance between Connecting Rod ⑤ and Rod End ②, so that Needle Bar moves in the center of the clearance between the upper and lower Presser Bar Bushings. (Needle Bar stroke is 37 mm).

To fix Eccentric Cam ⑦ on Main Shaft ⑧, tighten the Screws ⑨ and ⑨' on Main Shaft ⑧ (Eccentric Cam ⑦ should contact Spacer ⑩ slightly).

The position of Needle is adjusted so that the distance between the point of Needle (at its highest position) and Throat Plate is 13 mm, after loosening screw on Needle Bar Connection Assembly ⑥ in Fig. 12.

① Screw 11/64S40089

② Rod End 6APOS8

③ Needle Bar Lever 242051A

④ Nut 1N8

⑤ Connecting Rod Assembly 242011A

⑥ Needle Bar Connection Assembly 242101A

⑦ Eccentric Cam (part of Connecting Rod Assembly) 242011

⑧ Main Shaft 241101

⑨ ⑨' Screw 11/64S40001

⑩ Spacer 241161

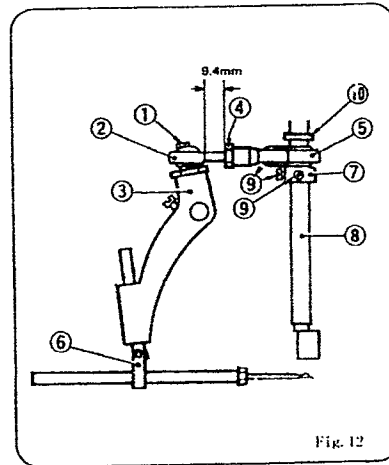

Fig. 12

5. LUBRICATOR

1. Operation

The lubricator comprises a pump and a reservoir. The reservoir holds max 45 cc of oil. (Effective oil volume is 28 cc.)

Use mineral oil 22 - 32 cSt at 40°C (Eg. Tellus oil #32).

To operate the lubricator:

1. First unscrew the reservoir cap by half a turn. *
2. Push the button to its lowest position (stroke: 12mm).
3. When released, the button will automatically return to its original position.
4. Lastly, tighten the cap to prevent oil leak during operation.

* Repeated working on the button without first loosening the cap may produce negative pressure in the reservoir, and the dust in the atmosphere

may be easily introduced in it when the cap is loosened.

2. Maintenance

1. Keep off dust or foreign matter when to fill oil (They may cause jamming of the piston and the check valve).
2. Rate of discharge is fixed and not adjustable (0.08cc per push).
3. At high temperatures, grease may run along points A. This is normal, grease being used when the lubricator was assembled in our plant.
4. Reservoir is made of high density polyethylene. Keep off fire and refrain from using organic, benzene, or xylene chemicals for cleaning. Check periodically for correct working of the pump. (Repeat oil feed and look at the oil through the discharge pipe.)

Troubleshooting

Trouble	Cause	Remedy
Oil not fed.	Low oil level.	Fill oil.
Full stroke movement not obtainable.	Dust attached on the interior wall of the pumping chamber.	Replace lubricator.
Button will not return.	Dust accumulated, or break of spring.	Replace lubricator.
Oil leak fromⒶ	Wornout or displaced seal of O - Ring.	Replace lubricator.
Oil leak fromⒷ	Wornout or displaced seal of packing.	Replace lubricator.
Oil leak fromⒸ	Loose plug.	Tighten plug or Replace lubricator.

PUSH - BUTTON LUBRICATOR

6. MAINTENANCE

Clean the machine at the end of the day's work, and oil the bushings, shaft; ect. that are not lubricated by a lubricator. Wipe dust and other foreign matter off the Feed Dog teeth Looper and Throat Plate eyelet where they are easily gathered. Care should be taken to keep the machine free from dust, especially when to leave it unused for some time.

Important!

The motor body should not be opened for the maintenance.

When adjusting the machine or replacing parts, always disconnect the Electric Cord from the power source.

This is important in view of safety to the operator and adjuster.

[NOTES ON CARRYING AND STORAGE]

1. Carry the machine in a storage box.
2. After the use of the machine, remove the plug, clean the dirt, take the thread from the machine and then put it into a storage box.
We suggest you to use a soft brush to clean the rear of the machine.
3. Never store the machine under the sunlight dried or wet condition.

7. ORDERING PARTS

The parts list showing all the parts used in the machine is included in this book.

Check the list, and specify parts numbers and quantities required clearly.

Send your order to the nearest agent, distributor or one of our branch offices.

1. Description of each part and its stamp number is described in this parts list. Screws and nuts for parts are shown adjacent to the relevant parts. When ordering parts, describe clearly stamp number with its name of part.
 2. The parts which have no Ref. Number can not be delivered independently; always order it as an assembly.
 3. A set of assembled parts is represented by the stamp number of its main parts.
 4. The last figure on the parts stamp number advances on each improvement of the parts.
 5. Parts No. described in [] of Remarks means old parts No.
- * The parts list is subject to change without prior notice.

CONTENTS

(1) THREAD TENSION AND COVERS PARTS	8
(2) BUSHING, OILINGS AND HANDLE PARTS	10
(3) NEEDLE BAR , PRESSER BAR AND DRIVING PARTS	12
(4) LOOPER DRIVING PARTS	14
(5) FEED DRIVING AND THREAD CUTTER PARTS	16
(6) MOTOR PARTS(For Totally Enclosed Type Motor)	18
(7) SPECIAL PARTS FOR GK26 – 1H TYPE	20

(1) THREAD TENSION AND COVER PARTS

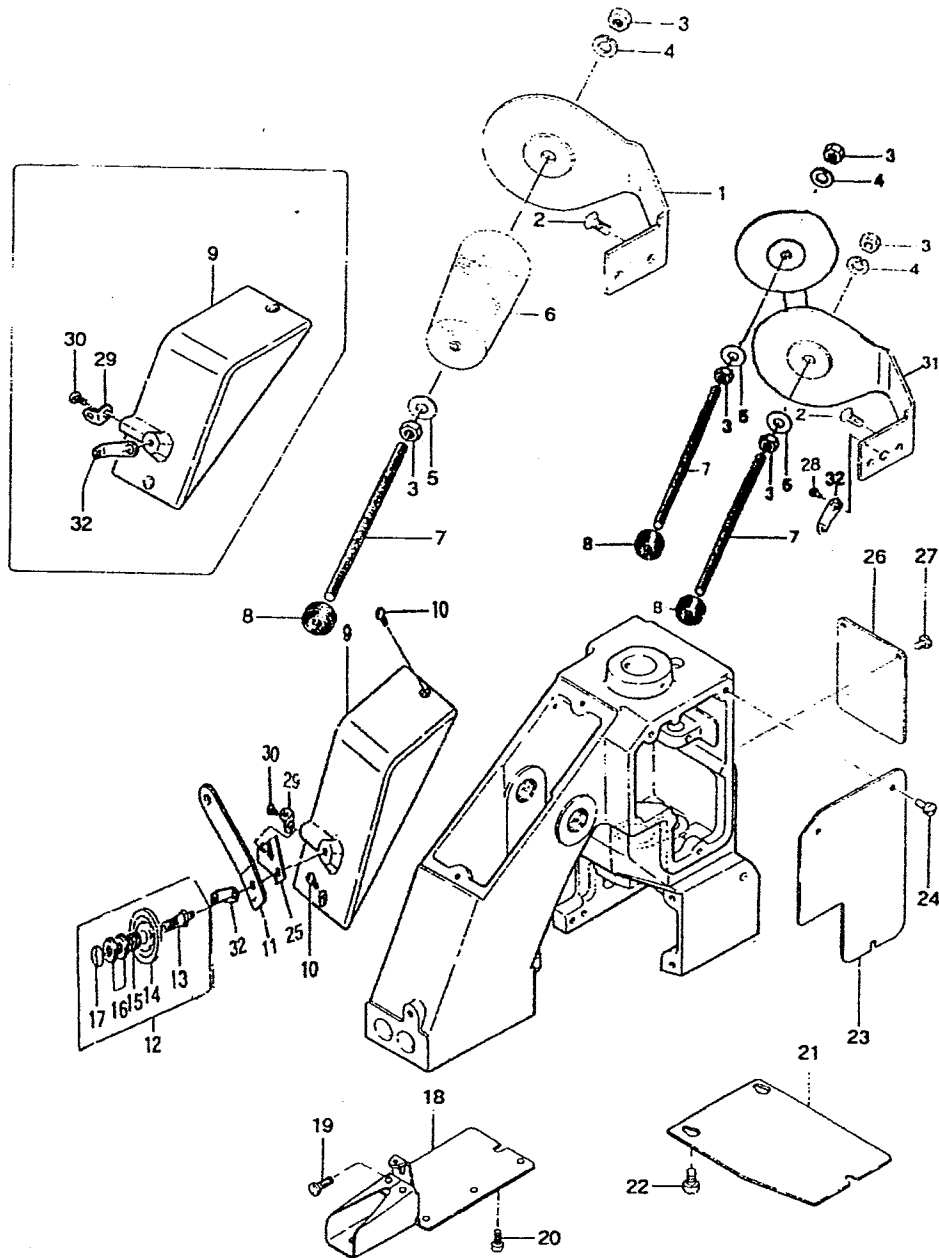

(1) THREAD TENSION AND COVER PARTS

Ref No.	Part No.	Description	Part No. NP-7	Q' ty	Remarks
1	1-30-3	Thread Stand	245042	1	
2	1-37	Screw, for 245042	15/64S28028	2	
3	GB6175-86	Nut	1N6	2	GK26-2 4
4	GB859-87	Spring Washer	3W6	1	GK26-2 2
5	GB95-85	Washer	2W6	1	GK26-2 2
6		Thread	K01001	1	GK26-2 2
7	1-30-1	Thread Cone Clamping Rod	245052	1	GK26-2 2
8	1-30-2	Thread Cone Clamping Nut	245201	1	GK26-2 2
9	1-21	Top Cover	245014	1	
10	S40	Screw for 245014	9/64S40005	2	
11	1-39	Thread Eyelet	245551	1	GK26-2
12		Thread Tension Assembly	245081A	1	(13-17)
13	1-17	Tension Post	245081	1	
14	R56	Tension Disc	065261	2	
15	1-20	Tension Spring	245101	1	
16	1-19	Tension Nut	245091	2	
17	1-18	Screw, for 245081A	9/64S40011	1	
18	1-11	Needle Bar Guard	245033	1	
19	S40	Screw, for 245033	9/64S40065	1	
20	S40	Screw, for 245033	9/64S40065	2	
21	1-10	Looper Cover	245222	1	
22	S40	Screw, for 245222	9/64S40065	3	
23	1-12	Side Plate	245022	1	
24	S40	Screw, for 245022	9/64S40005	3	
25	1-40	Thread Tension Eyelet		1	GK26-2
26	1-13	Inside Cover	245302	1	
27	S40	Screw, For 245302	9/64S40005	4	
28	GS55	Screw	11/64S40	1	GK26-2
29	1-35	Thread Eyelet	245261	1	
30	S40	Screw, for 245261	11/64S40006	1	
31	1-30-3A	Thread Stand		1	GK26-2
32	1-16	Thread Tension Eyelet	245071	1	GK26-2 2

(2) BUSHINGS, OILINGS AND HANDLE PARTS

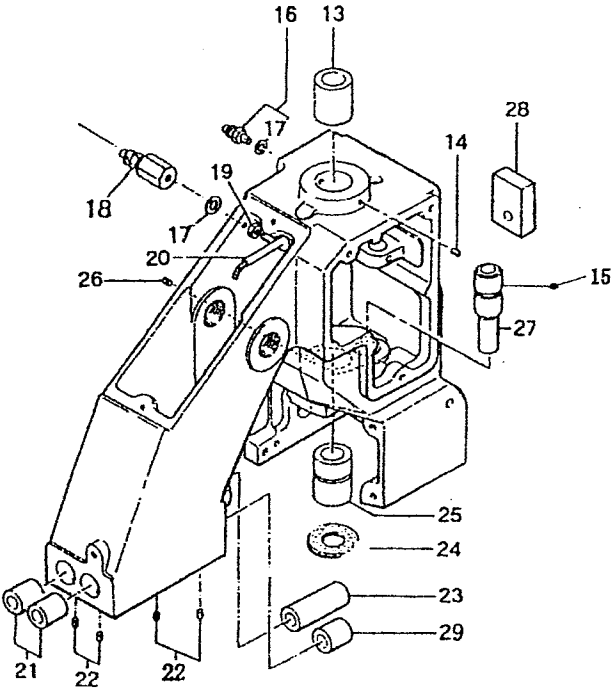
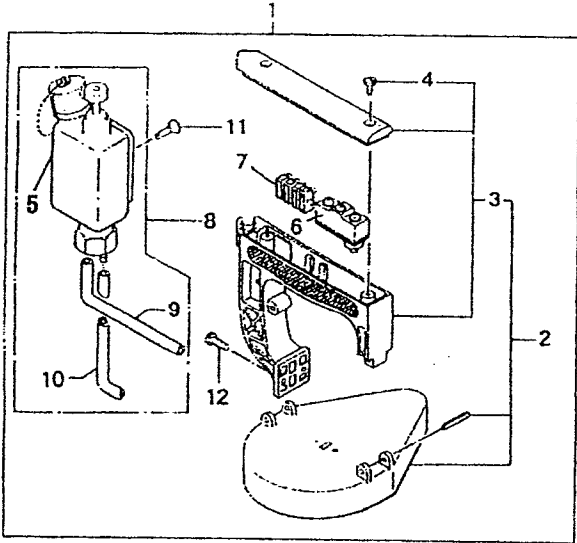

(2) BUSHINGS, OILINGS AND HANDLE PARTS

Ref No.	Part No.	Description	Part No. NP-7	Q'ty	Remarks
1		Handle Assembly	241024AS	1	
2		Handle Assembly	241024A	1	(3-4)
3	1-2	Handle	241024	1	
4	1-18	Screw, for 241024A	9/64S40011	2	
5	6-0	Pump		1	
6	Lx5-11/D	Micro Switch(Z-15GK655-B)	C02001	1	
7	X ₅ C ₀ V ₁ °A	Flexible Terminal Block (ML - SK-1,4P)	C05008	1	
8		Oiler	D03003	1	
9		Oil Tube, with oil felt	8EU2-6×90F	1	
10		Oil Tube, with oil felt	8FU2-6×60F	1	
11	GB68-85	Screw, for D03003	6S5×15	1	
12	1-36	Screw, for 241024A	15/64S28021	2	
13	2-11	Main Shaft Bushing, rear	241122	1	
14	S38	Screw, for 241122	11/64S40	1	
15	S38		11/64S40	1	
16	6-14	Joint(BN-5-6)	D07021	1	
17	7-7	Washer	E03014	2	
18	6-15	Joint	245471	1	
19	GB6175-86	Nut	1N4	1	
20	6-17	Oil Pipe	245461	1	
21	2-2	Bushing for Presser Bar & Needle Bar, upper	242212	2	
22	S38	Screw, for 242212	11/64S40	4	
23	5-8	Presser Bar Bushing, lower	242222	1	
24	4-19	Oil Felt	245541	1	
25	2-22	Main Shaft Bushing, lower	241111	1	
26	S38	Screw, for 241111	11/64S40	1	
27	3-4	Looper Rocker Shaft Bushing	243021	1	
28	3-5	Oil Felt	245162	1	
29	2-4	Needle Bar	242212	1	

(3) NEEDLE BAR, PRESSER BAR AND DRIVING PARTS

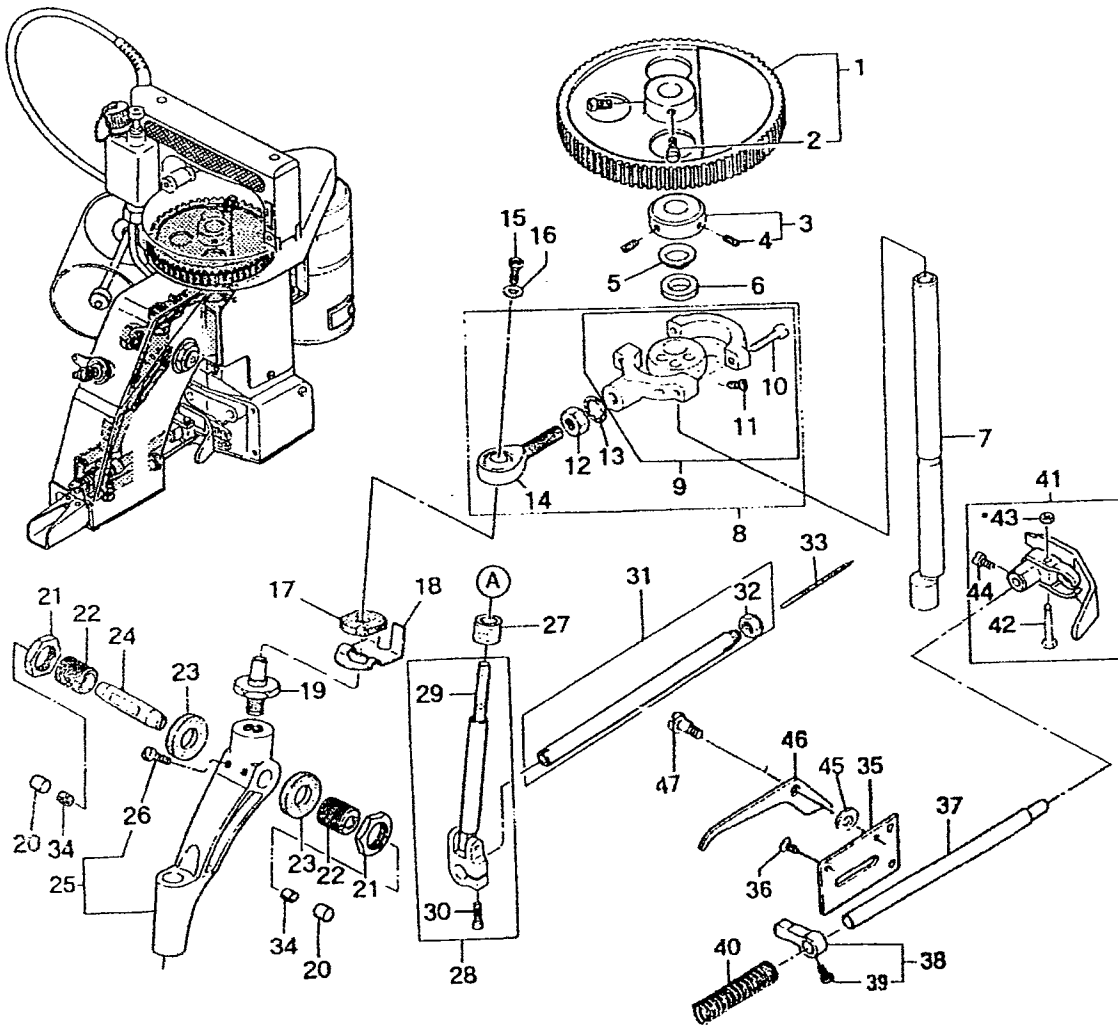

(3) NEEDLE BAR, PRESSER BAR AND DRIVING PARTS

Ref No.	Part No.	Description	Part No. NP-7	Q'ty	Remarks
1	1-23	Synchro Pulley	241092	1	
2	S30	Screw, for 241092	11/64S40	2	
3	2-13	Retaining Collar	241131	1	
4	GS55	Screw, for 241131	11/64S40502	2	
5	2-10	Spacer	241161	1	
6	2-9	Oil Felt	205131	1	
7	2-12	Main Shaft	241102	1	
8		Connecting Rod Assembly	242011A	1	
9	2-8-1	Connecting Rod Sub - Assembly	242011	1	
10	2-8-2	Screw, for connecting rod cap	3/16S28029	2	
11	GS55	Screw, for eccentric cam	11/64S40001	2	
12	GB6175-86	Nut, for 242011A	1N8	1	
13	GB861-2-87	Washer, for 242011A	5W8	1	
14	2-8-5	Rod End(POS-8)	6A04001	1	
15	4-11	Screw, for 242031	3/16S32	1	
16	GB95-85	Washer, for 242031	11/64W15103	1	
17	2-15	Oil Felt	245211	1	
18	2-14	Spring	242041	1	
19	2-16	Rod End Stud	242031	1	
20		Cap	245491	2	
21	2-19	Nut, for 242081	5/8N18101	2	
22	2-18	Adjusting Stud	242081	2	
23	2-21	Oil Felt	245231	2	
24	2-20	Needle Bar Lever Stud	242071	1	
25	2-7	Needle Bar Lever Assembly	242051A	1	
26	S30	Screw, for 242051A	11/64S40004	2	
27	2-3-3	Oil Felt	245371	1	
28	2-3-1 2-3-2 2-3-4	Needle Bar Connection Assembly	242101A	1	
29	2-3-5	Oil Felt	205171	1	
30	GS55	Screw, for 242101A	11/64S40003	1	
31	2-1	Needle Bar with Nut	242121A	1	
32	2-5	Needle Clamp Nut	242131	1	
33	2-6	Needle(DN×1 #25)	B01002	1	
34		Oil Felt	055561	2	
35	5-5	Presser Foot Lifter Base	242172	1	
36	S47	Screw, for 242172	11/64S40002	3	
37	5-9	Presser Bar	242201	1	
38	5-7	Presser Bar Connection	242181	1	
39	GS55	Screw, for 242181	11/64S40003	1	
40	5-6	Presser Spring	242191	1	
41		Presser Foot Assembly	242231A	1	
42	5-2	Screw	9/64S40055	1	
43	5-1	Nut	9/64N40101	1	
44	GS55	Screw, for 242231A, 242233A	11/64S40005	1	
45	5-13	Washer		1	
46	5-12	Presser Foot Lifter	242161	1	
47	5-14	Screw, for 242161		1	

(4) LOOPER DRIVING PARTS

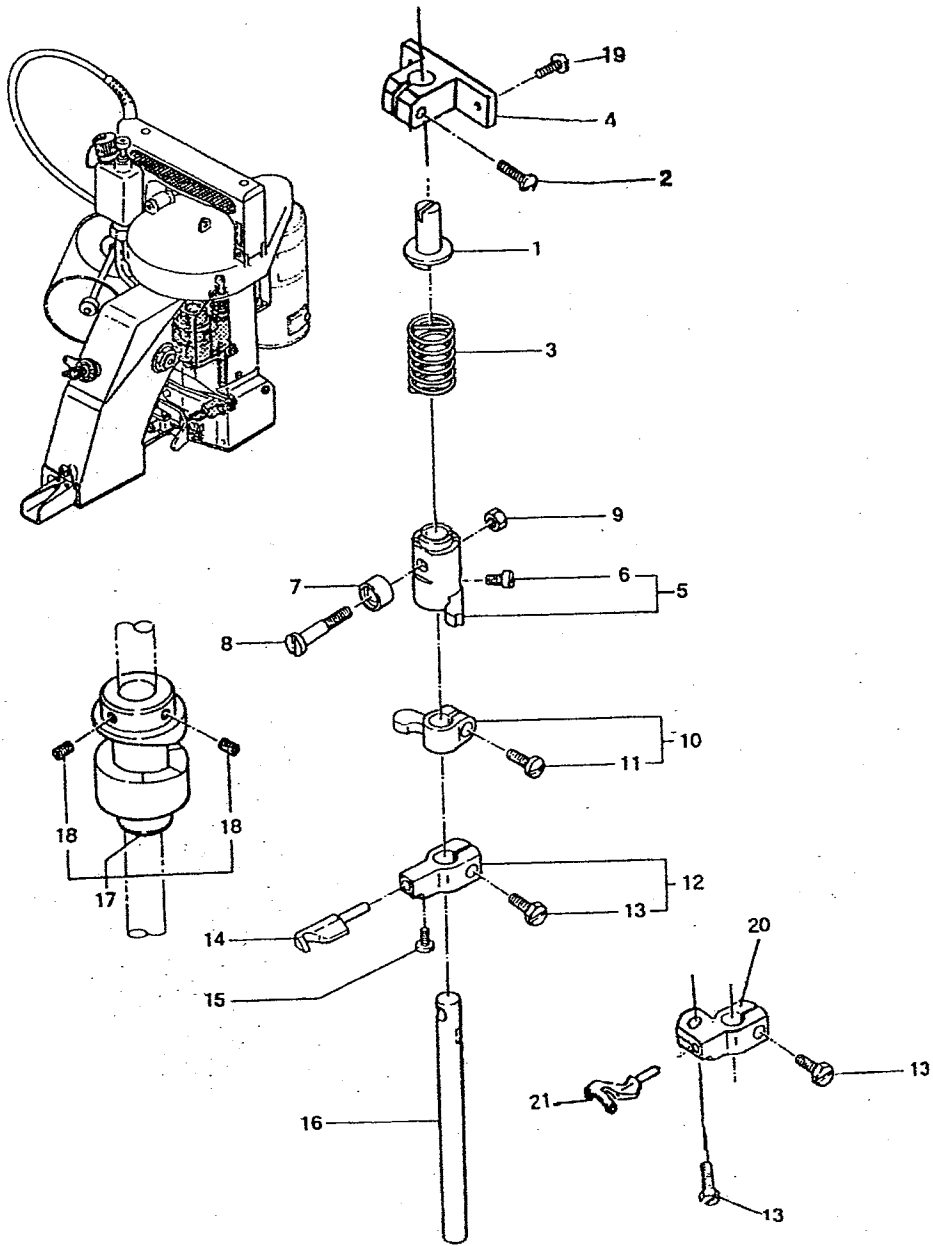

(4) LOOPER DRIVING PARTS

Ref No.	Part No.	Description	Part No. NP-7	Q' ty	Remarks
1	3-14	Spring Supporter	243121	1	
2	S30	Screw	11/64S40	1	
3	3-12	Spring	243131	1	
4	3-13	Spring Supporter Block	243111	1	
5	3-8	Looper Rocker Shaft Arm(A)	243071	1	
6	GS55	Screw, for 243071	11/64S40	1	
7	3-11	Roller	243041	1	
8	3-9	Roller Stud Screw	243061	1	
9	3-10	Nut, for 243061	11/64N40201	1	
10	3-7	Looper Rocker Shaft Arm(B)	243081	1	
11	GS55	Screw, for 243081	11/64S40	1	
12	3-2	Looper Rocker	243092	1	
13	3-15	Screw, for 243092	11/64S40089	1	GK26-2 2
14	3-1	Looper	243102	1	
15	S40	Screw, for 243102	9/64S40001	1	
16	3-3	Looper Rocker Shaft	243032	1	
17	3-6	Looper Drive Cam	243012	1	
18	S2	Screw, for 243012	15/64S28524	2	
19	S40	Screw	9/64S40	2	
20	3-2A	Looper Rocker		1	GK26-2
21	3-1A	Looper		1	GK26-2

(5) FEED DRIVING AND THREAD CUTTER PARTS

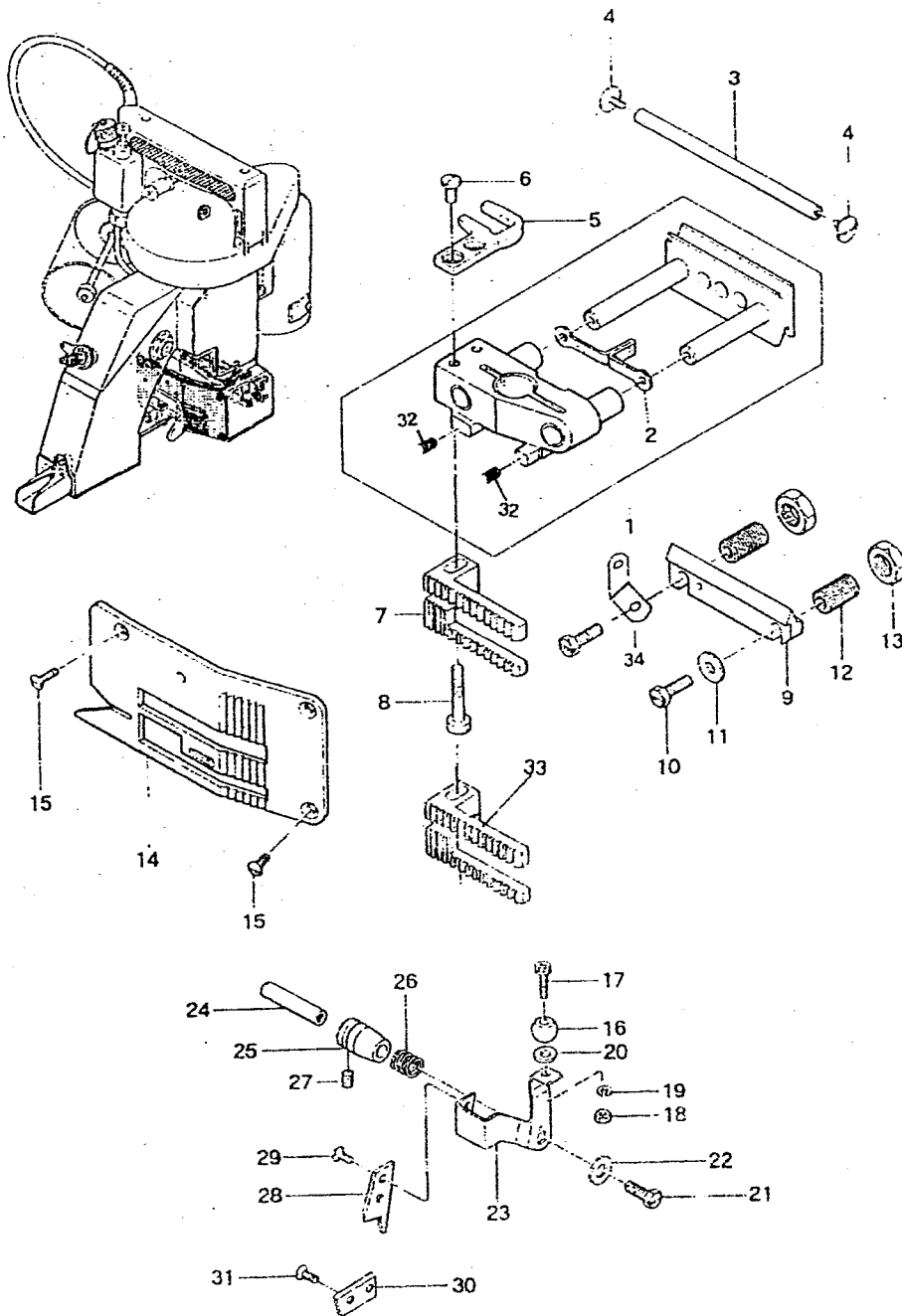

(5) FEED DRIVING AND THREAD CUTTER PARTS

Ref No.	Part No.	Description	Part No. NP-7	Q'ty	Remarks
1	4-18	Feed Dog Carrier Block Assembly	244011A		
2	4-21	Oil Felt	245391	1	
3	4-25	Slide Block Guide Stud	244102	1	
4	1-18	Screw, for 244102	9/64S40011	2	
5	4-15	Knife Bracket Extension	246011	1	
6	4-11	Screw, for 246011	3/16S32031	2	
7	4-14	Feed Dog	244111	1	
8	4-12	Screw, for 244111	3/16S32034	1	
9	4-24	Slide Block Adjusting	244081	1	
10	4-23	Lock Bolt, for 244091	3/16S32025	2	
11	2-24	Washer, for 244091	11/64W15103	2	GK26-2 1
12	4-2	Stud Slide Block Adjusting Support	244091	2	
13	4-1	Lock Nut, for 244091	3/8N24201	2	
14	4-13	Throat Plate	244122	1	
15	4-10	Screw, for 244122	9/64S40043	3	
16	4-9-2	Ball	246081	1	
17	GB5783-86	Bolt, for 246081(M3×0.5×121)	4B×12	1	
18	GB6175-86	Nut, for 246081(M3×0.5)	1N3	1	
19	GB3859-87	Spring Lock washer(M3)	3W3	1	
20	GB95-85	Washer, for 246081(M3)	1W3	1	
21	GS55	Screw, for 246021	11/64S40049	1	
22	GB95-85	Washer, for 246021	11/64W15103	1	
23	4-9-1	Knife Bracket	246021	1	
24	4-5	Knife Bracket Pin	246032	1	
25	4-4	Bushing, for 246032	246042	1	
26	4-6	Knife Tension Spring	246051	1	
27	S38	Screw, for 246042	11/64S40	1	
28	4-9-3	Knife Moving	246061	1	
29	4-7	Screw, for 246061	1/8S40003	2	
30	4-8	Knife Stationary	246071	1	
31	4-7	Screw, for 246071	1/8S40003	2	
32	4-17	Screw		2	
33	4-14A	Feed Dog		1	GK26-2
34	1-35	Thread Eyelet		1	GK26-2

(6) MOTOR, PARTS (For Totally Enclosed Type Motor)

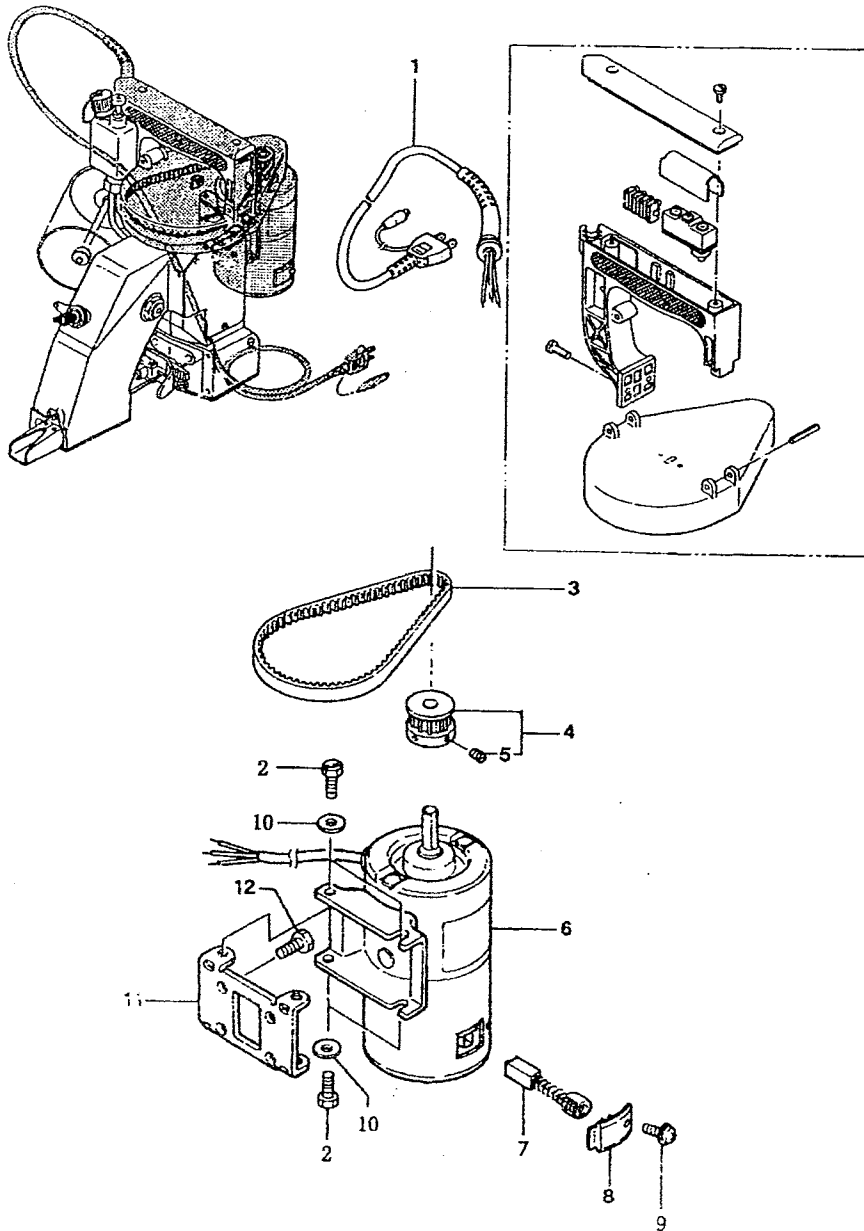

(6) MOTOR, PARTS (For totally Enclosed Type Motor)

Ref No.	Part No.	Description	Part No. NP-7	Q'ty	Remarks
1	1-9	Cabtyer Cord, With Plug (Standard Type)	C04001	1	
		Cabtyer Cord, With Plug (American Type)	C04003	1	
		Cabtyer Cord, Word, With Plug (British Type)	C04004	1	
		Cabtyer Cord, With Plug (German Type)	C04005	1	
		Cabtyer Cord, With Plug (French Type)	C04006	1	
		Cabtyer Cord, With Plug (Australian Type)	C404007	1	
		Cabtyer Cord, With Plug (South Africa Type)	C04012	1	
2	3-15	Screw	11/64S40091	4	
3	1-22	Timing Belt	F01001	1	
4	1-29	Motor Pulley	241083	1	
5	S38	Screw, for 241083		2	
6		Universal Motor (220V - 90W)	C01028	1	
		Universal Motor (240V - 90W)	C01029	1	
		Universal Motor (110V - 90W)	C01030	1	
7		Carbon Brush	C08004	2	
8		Cap	C07003	2	
9	GB818-85	Screw	4S3×6-W	2	
10	GB95-85	Washer	11/64W10101	4	
11	1-27	Motor Base B	241073	1	
12	1-32	Screw, for 241073	15/64S28004	4	

(7) SPECIAL PARTS FOR GK26 - 1H

Ref No.	Part No.	Description	Part No. NP-7	Q'ty	Remarks
1	1-2-1	Handle	241024	1	GK26-1 H
2	1-18	Screw	9/64S40011	2	
3	1-2-2	Pulley Cover	241212	1	GK26-1 H
4	GB65-85	Screw, for 241053	9/64S40004	2	GK26-1 H
5	GB65-85	Screw, for 241053	9/64S40052	1	GK26-1 H
6	7-1	Pulley Cover Holder A	241242	1	GK26-1 H
7	1-32	Screw, for 241242	15/64S28004	2	
8	7-2	Pulley Cover Holder B	241231	1	GK26-1 H
9	S40	Screw, for 241231	9/64S40005	1	
10	7-3	Handle Base	241223	1	GK26-1 H
11	GB70-85	Screw, for 241253	15/64S28032	2	
12	7-4	Handle Base Holder	241253	1	GK26-1 H
13	7-5	Joint(BN-5-6)	D07021	4	GK26-1 H
14	7-7	Washer	E03014	3	
15	6-15	Joint		1	
16		Oil Tube ($\phi 6 \times 95\ell$), With oil felt	8FU2 - 6 \times 95F	2	
17		Oil Tube ($\phi 6 \times 70\ell$), With oil felt	8FU2 - 6 \times 70F	1	
18	6-17	Oil Pipe	245462	1	
19	7-6	Tube Dlip	DO7009		