

ARTISAN

1-Needle, Unison-feed, Lockstitch Machine

DNU-1541

1-Needle, Unison-feed, Lockstitch Machine
(with a Safety Device For Hook)

DNU-1541S

PARTS LIST

1.FRAME & MISCELLANEOUS COVER COMPONENTS

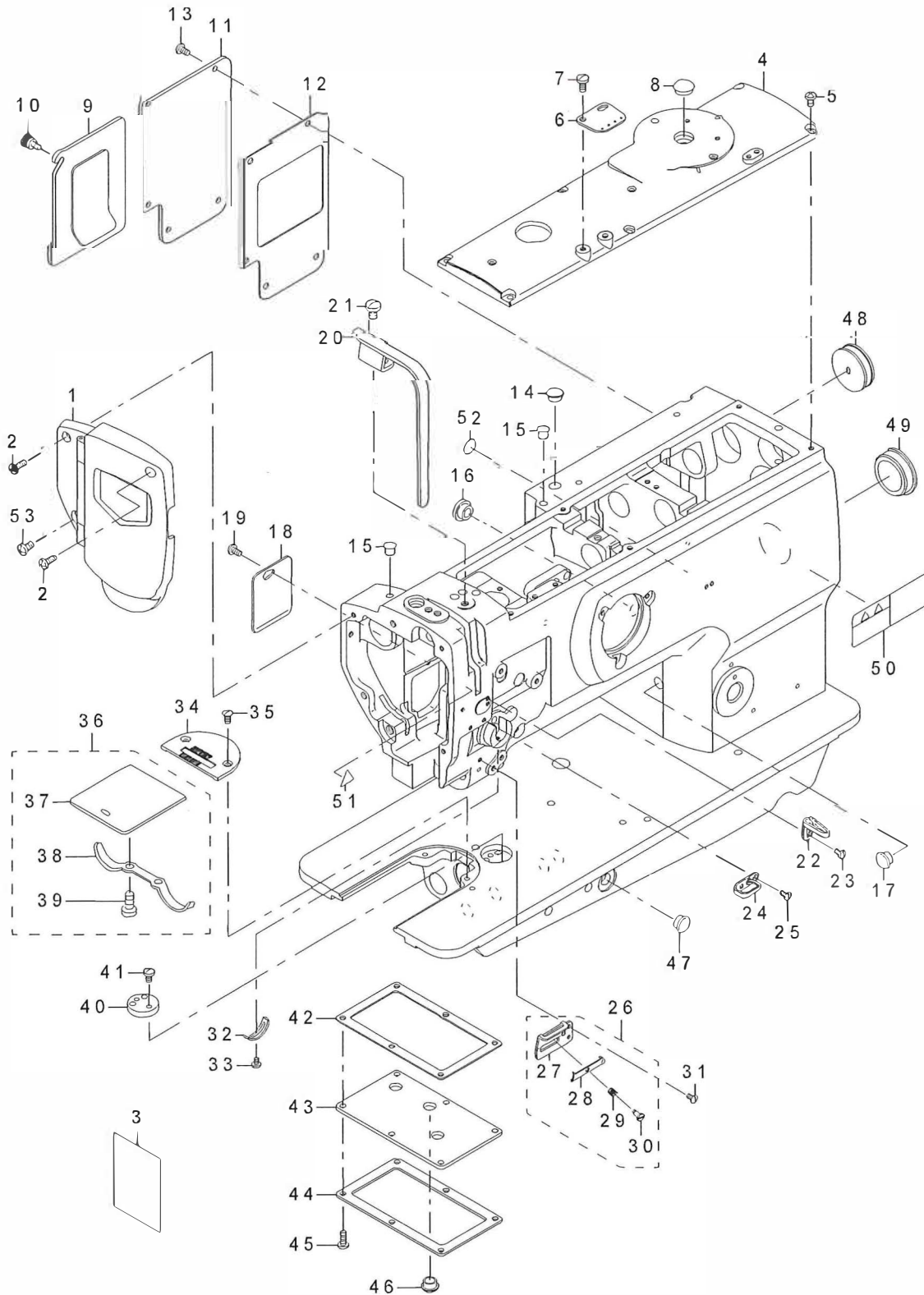

No	note	Parts No.	DESCRIPTION	Qty
1		40016798	FACE PLATE ASM.	1
2		SS4111215SP	SCREW 11/64-40 L=12	2
3		40019114	LUBRICATION SUPPLEMENT	1
4		21331301	TOP COVER B	1
5		SS4110815SP	SCREW 11/64-40 L=8	6
6		21355904	ARM THREAD GUIDE	1
7		SS7621040SP	SCREW 3/16-32 L= 9.5	2
8		TA1450404R0	RUBBER PLUG D=14.5 L=4	1
9		21331756	WINDOW PLATE A ASM.	1
10		21331202	SETScrew	1
11		21331806	WINDOW PLATE B	1
12		21332002	WINDOW PLATE PACKING B	1
13		SS4110815SP	SCREW 11/64-40 L=8	5
14		TA1250504R0	RUBBER PLUG	1
15		TA0750704R0	RUBBER PLUG	2
16		TA1250504R0	RUBBER PLUG	1
17		TA1050504R0	RUBBER PLUG	1
18		21332309	SIDE COVER	1
19		SS4110815SP	SCREW 11/64-40 L=8	1
20		21331608	BALANCE COVER	1
21		SS7150910TP	SCREW 15/64-28 L=9	1
22	#02	40108674	THREAD GUIDE	1
23	#02	SS5090610SP	SCREW 9/64-40 L=6	1
24		40108675	FRAME THREAD GUIDE	1
25		SS2090710TP	SCREW 9/64-40 L=7.2	2
26		21408554	THREAD GUIDE ASM.	1
27		21408505	THREAD GUIDE PLATE	(1)
28		17912106	NEEDLE THREAD PRESSER PLATE	(1)
29		B1132521000	THREAD PRESSER PLATE SPRING	(1)
30		SD0380551SL	HINGE SCREW D= 3.80 H= 5.5	(1)
31		SS2090710TP	SCREW 9/64-40 L=7.2	1
32		B3138512000	TAKE-UP SPRING ADJUSTING PLATE	1
33		SS7090520TP	SCREW 9/64-40 L= 4.5	1
34		21410006	THROAT PLATE	1
35		SS2110920TP	SCREW 11/64-40 L=8.5	2
36		B1112241HA0	BED SLIDE ASM.	1
37		B1112241H00	BED SLIDE	(1)
38		A1111007000	SLIDE PLATE SPRING	(1)
39		SS6060210SP	SCREW 3/32-56 L= 1.9	(2)
40		B1103141H00	SCALE BASE PLATE	1
41		SS7110720SP	SCREW 11/64-40 L=7	2
42		21401302	GASKET	1
43		21401401	OIL TANK COVER	1
44		21401500	OIL TANK COVER PLATE	1
45		SS4111015SP	SCREW 11/64-40 L=10	6
46		TA1050504R0	RUBBER PLUG	3
47		TA1050504R0	RUBBER PLUG	1
48		10201200	RUBBER PLUG	1
49		22619100	CAP	1
50		CM301300001	SAFETY LABEL	1
51	#01	CM300200001	ATTENTION SEAL	1
52		22901805	GROUND MARK	1
53		SS4150915SP	SCREW 15/64-28 L=9	1

1...#01EXCEPT USE IN JAPAN / 2...#02FOR DNU-1541·DNU-1541S / 3... /

DNU-1541/DNU-1541H/DNU-1541S
2. UPPER SHAFT DRIVING & BALANCE COMPONENTS

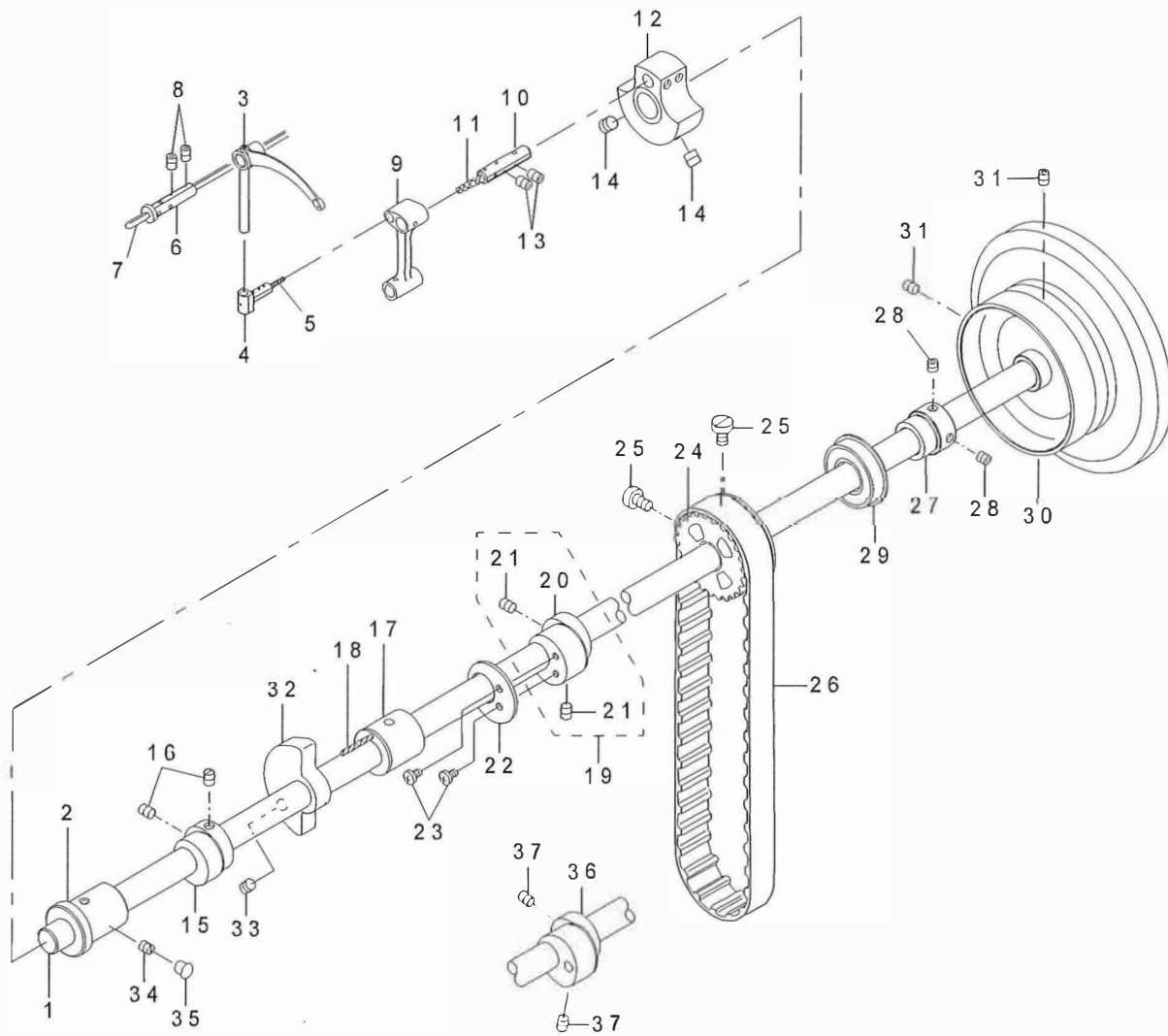

DNU-1541/DNU-1541H/DNU-1541S
 2.UPPER SHAFT DRIVING & BALANCE COMPONENTS

No	note	Parts No.	DESCRIPTION	Qty
1		21332705	UPPER SHAFT	1
2		21333000	UPPER SHAFT FRONT METAL	1
3		21401906	THREAD TAKE-UP LEVER	1
4		22605406	TAKE-UP LEVER THRUST PIN	1
5		CQ202000000	OIL WICK	0.03
6		B1906051000	TAKE-UP LEVER PIN	1
7		CQ303000000	OIL WICK	0.45
8		SS8150822TP	SCREW 15/64-28 L=8	2
9		21339106	NEEDLE BAR CRANK ROD	1
10		B1210051000	NEEDLE BAR CRANK PIN	1
11		CQ505000000	OIL WICK	0.03
12		21332507	COUNTER WEIGHT (A) (36MM)	1
13		SS8150822TP	SCREW 15/64-28 L=8	2
14		SM8080812TP	SCREW M8X8	2
15		21339502	UPPER FEED CAM (3.5)	1
16		SS8660810TP	SCREW 1/4-40 L=8	2
17		21333109	UPPER SHAFT INNER METAL	1
18		CQ202000000	OIL WICK	0.15
19	#01	21336557	ECCENTRIC CAM A ASM.	1
20		21336508	ECCENTRIC CAM A	(1)
21		SS8660810TP	SCREW 1/4-40 L=8	(2)
22	#01	21353008	HORIZONTAL FEED CAM COVER	1
23	#01	SS7110710SP	SCREW 11/64-40 L=7	2
24		22604904	UPPER SPROCKET	1
25		SS6661110SP	SCREW 1/4-40 L=11	2
26		22604300	TIMING BELT	1
27		21402300	UPPER SHAFT BEARING HOOK	1
28		SM8060602TP	SCREW M6X6	2
29		B1203512000	BUSHING REAR	1
30		21334008	FLYWHEEL	1
31		SS8150822TP	SCREW 15/64-28 L=8	2
32		21333406	BALANCER	1
33		SS8151550SP	SCREW 15/64-28 L=15	2
34		SS8150710TP	SCREW 15/64-28 L=7	1
35		TA0750704R0	RUBBER PLUG	1
36	#02	40019905	TRIANGULAR CAM A	1
37	#02	SS8660810TP	SCREW 1/4-40 L=8	2

1...#01FOR DNU-1541 DNU-1541S / 2...#02FOR DNU-1541H / 3... /

DNU-1541/DNU-1541H/DNU-1541S
3.NEEDLE BAR ROCKING COMPONENTS

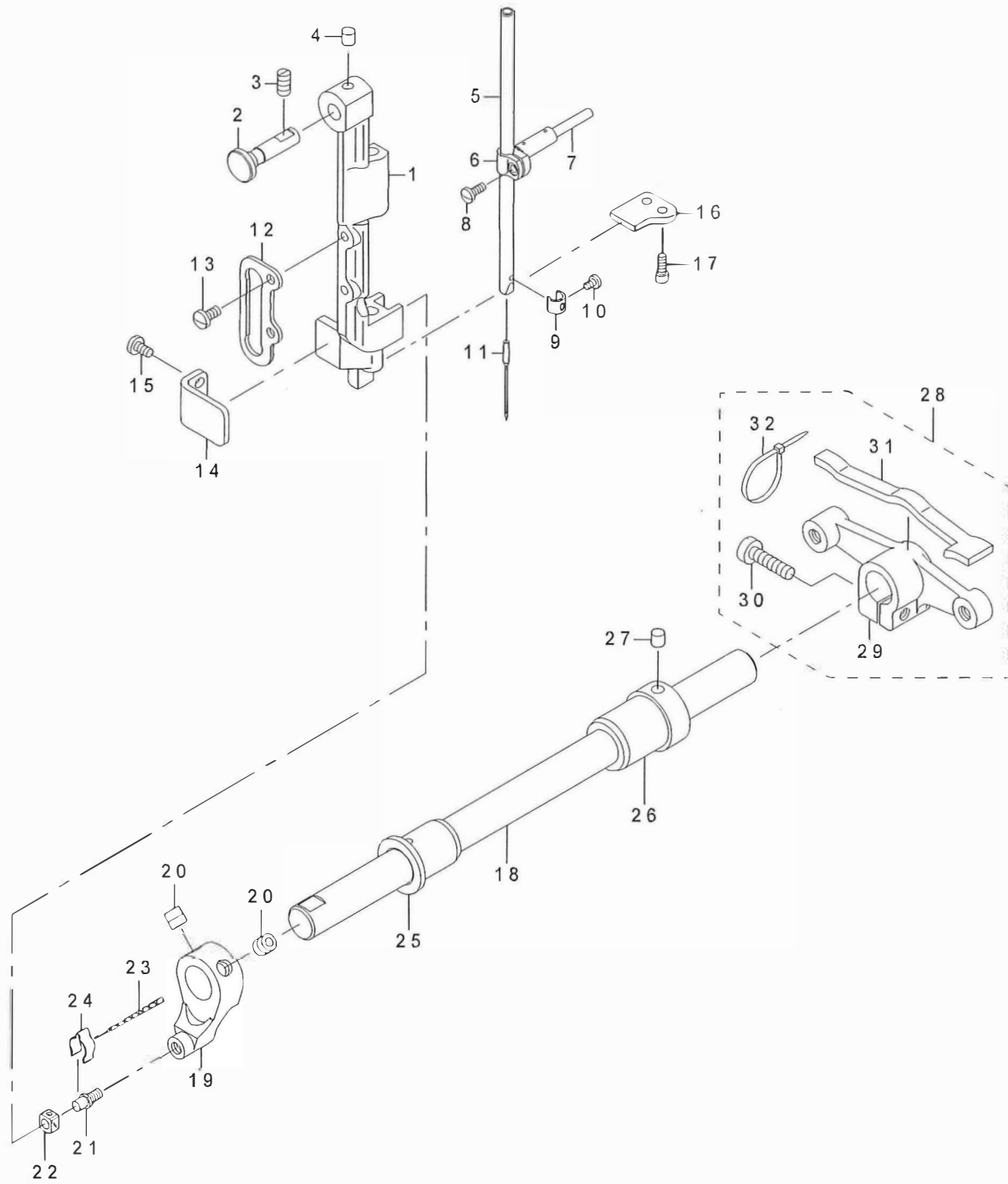

No	note	Parts No.	DESCRIPTION	Qty
1		B1420563000	NEEDLE BAR FRAME	1
2		21405204	HINGE STUD	1
3		SS8151150TP	SCREW 15/64-28 L=10.5	1
4		22814909	FELT	1
5		B1401053000	NEEDLE BAR	1
6		B1411053000	NEEDLE BAR CONNECTION	1
7		B1412051000	FELT	1
8		SS7090910SP	SCREW 9/64-40 L= 8.5	1
9		10308609	THREAD GUARD	1
10		SS7080510TP	SCREW 1/8-44 L=4.5	1
11		M1351731600	NEEDLE 135X17 #160	1
12		B1467563000	UPPER FEED BAR GUIDE	1
13		SS7110910TP	SCREW 11/64-40 L= 8.5	2
14		21388400	ROCKING BASE GUIDE	1
15		SS7110830SP	SCREW 11/64-40 L= 7.5	2
16		21338603	ROCKING BASE GUIDE (B)	1
17		SS6091022TP	SCREW	2
18		21338900	ROCKING SHAFT	1
19		21338801	ROCKING FRONT ARM	1
20		SM8080802TP	SCREW	2
21		B1410771000	STUD	1
22		B1414232000	SQUARE BLOCK	1
23		CQ202000000	OIL WICK	0.05
24		B1437051000	OIL WICK RETAINER	1
25		21339304	ROCKING SHAFT FRONT METAL	1
26		40027746	BUSHING REAR	1
27		22814909	FELT	1
28		21339056	ROCKING REAR ARM ASM.	1
29		21339007	ROCKING REAR ARM	(1)
30		SS6152440SP	SCREW 15/64-28 L=23.5	(1)
31		21347406	ROCKING REAR ARM FELT	(1)
32		EA9500B0100	CABLE BAND	(2)

1... /

4.PRESSURE ADJUSTING & UPPER FEED MECHANISM COMPONENTS

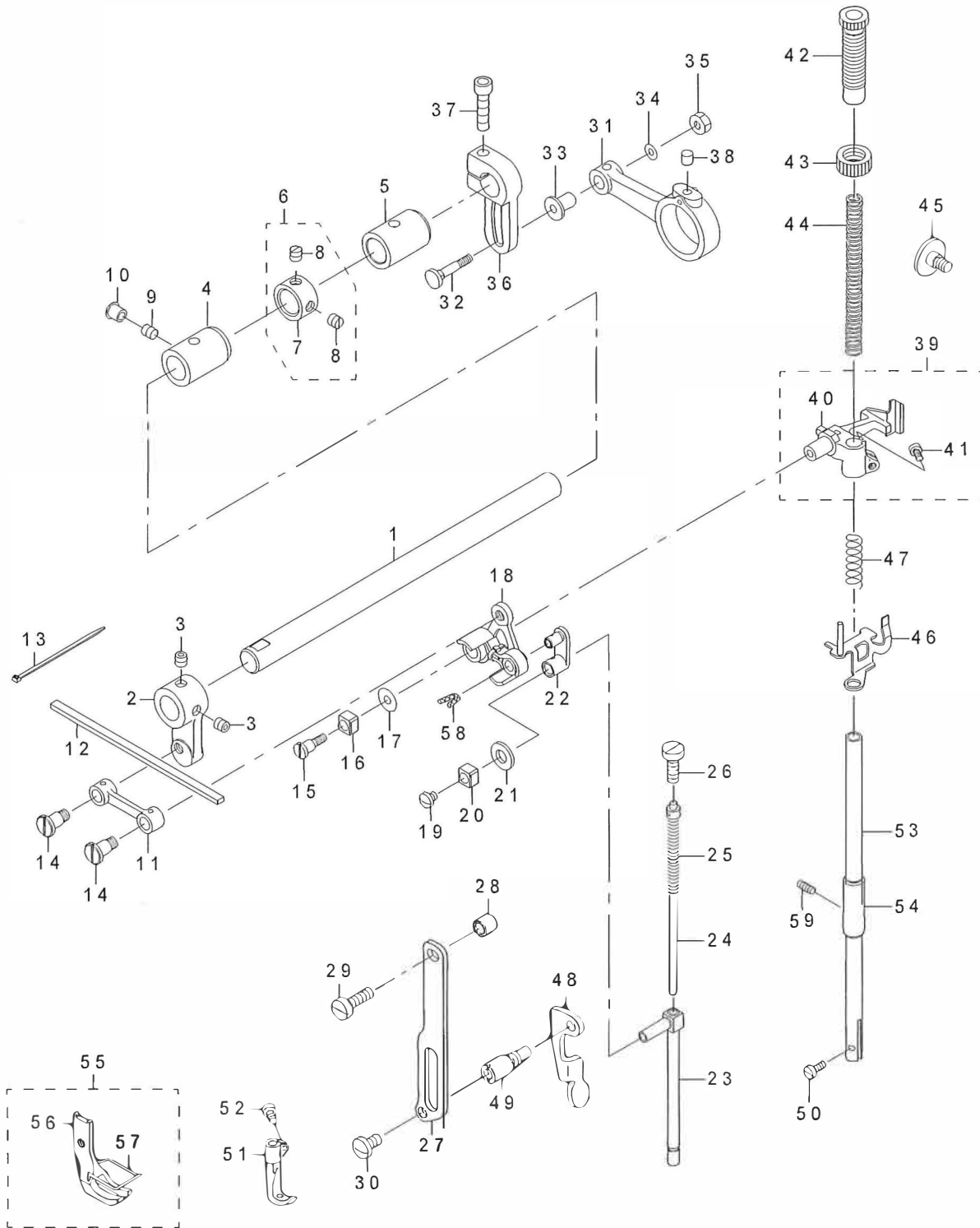

4.PRESSURE ADJUSTING & UPPER FEED MECHANISM COMPONENTS

No	note	Parts No.	DESCRIPTION	Qty
1		21340401	UPPER FEED SHAFT	1
2		21340500	UPPER FEED FRONT ARM	1
3		SS8660612TP	SCREW 1/4-40 L=6	2
4		21341904	FRONT METAL	1
5		21378302	FEED SHAFT METAL	1
6		22904155	MAIN SHAFT THRUST COLLAR ASM.	1
7		22904106	MAIN SHAFT THRUST COLLAR	(1)
8		SS8660610TP	SCREW 1/4-40 L=6	(2)
9		SS8150710TP	SCREW 15/64-28 L=7	1
10		TA0750704R0	RUBBER PLUG	1
11		40033026	UPPER FEED LINK	1
12		21347109	FELT	1
13		EA9500B0000	CLIP CV-70S	2
14		40018340	SCREW	2
15		40018339	SCREW	1
16		B1414555000	SLIDE BLOCK	1
17		WP0501046SC	WASHER 5 X 14 X 1	1
18		40033029	TRIANGULAR LEVER ASM.	1
19		SS7110510SP	SCREW 11/64-40 L=5	1
20		B1414555000	SLIDE BLOCK	1
21		10509701	FELT	1
22		40018341	WALKING BAR DRIVING LINK	1
23		40033030	WALKING BAR A	1
24		B14670530A0	WALKING BAR ASM.	1
25		B1468053000	WALKING BAR SPRING	1
26		SS6151780SP	SCREW 15/64-28 L=17.0	1
27		21406509	UPPER FEED GUIDE PLATE	1
28		26225201	ROLLER	1
29		SS6151920SP	SCREW 15/64-28 L=19.0	1
30		SS7150740SP	SCREW 15/64-28 L=7	1
31		21340104	UPPER FEED ROD	1
32		D1456055B00	HINGE SCREW	1
33		D1455055B00	CONNECTING STUD	1
34		WP0482086SD	WASHER 4.8X11.5X2	1
35		NS6110530SP	NUT 11/64-40	1
36		21437900	UPPER FEED REAR ARM	1
37		SM6062502TP	SCREW M6 L=25	1
38		22814909	FELT	1
39		40033032	PRESSER BAR HOLDER A ASM.	1
40		40033031	PRESSER BAR HOLDER A	(1)
41		SS7110910TP	SCREW 11/64-40 L= 8.5	(1)
42		21340906	PRESSER ADJUSTING SCREW	1
43		22907604	PRESSER SPRING REGULATOR NUT	1
44		B1502246000	PRESSER SPRING	1
45		SD0800481SP	HINGE SCREW D= 8 H= 4.9	1
46		21341151	THREAD RELEASE HOLDING PLATE	1
47		B1462053000	THREAD RELEASE SPRING	1
48		21406103	PRESSER LIFTER LEVER	1
49		21406608	GUIDE PLATE SPACER	1
50		SS6090910TP	SCREW 9/64-40 L=9	1
51		B1470241H00	WALKING FOOT	1
52		B1471241H00	SCREW	1
53		B1501241H00	PRESSER BAR	1
54		B1510155000	PRESSER BAR LOWER BUSHING	1
55		B1525241HA0	PRESSER FOOT ASM.	1
56		B1525241H00	PRESSER FOOT	(1)
57		10337905	FINGER GUARD	(1)
58		CQ252000000	OIL WICK	0.02
59		SS8111010TP	SCREW 11/64-40 L=9.5	1

1... /

DNU-1541/DNU-1541H/DNU-1541S
5. FEED MECHANISM COMPONENTS

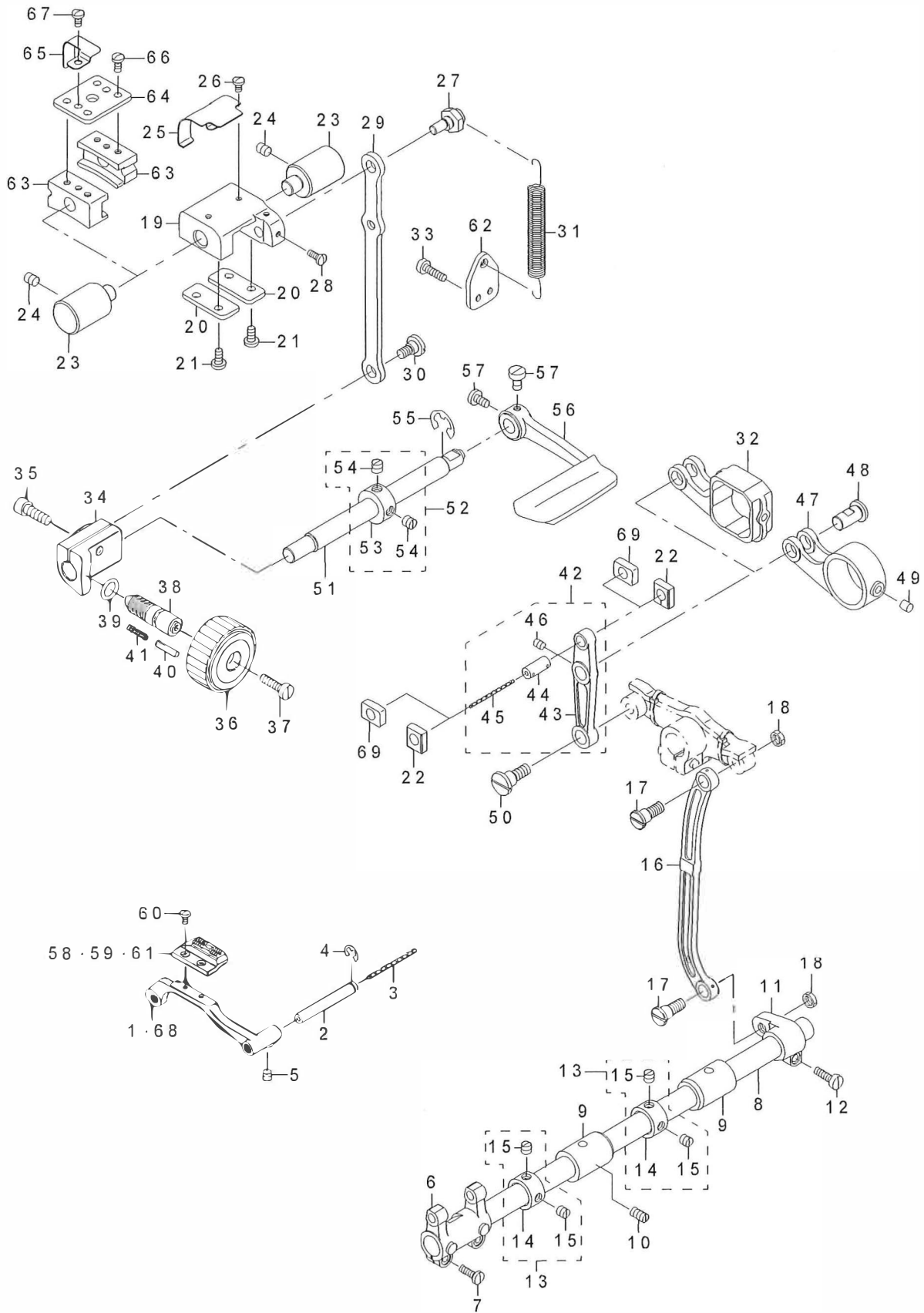

No	note	Parts No.	DESCRIPTION	Qty
1	#05	21405006	FEED BASE	1
2		B1604012000A	FEED BAR SHAFT	1
3		CQ202000000	OIL WICK	0.14
4		RE0500711KP	SNAP RING 5	1
5		SM8050512TP	SCREW	1
6		B1603512000	FEED ROCKER	1
7		SS7111410TP	SCREW 11/64-40 L=14	2
8		22609408	FEED ROCK SHAFT	1
9		21378302	FEED SHAFT METAL	2
10		SS8151150TP	SCREW 15/64-28 L=10.5	1
11		22609309	FEED ROCKER SHAFT CRANK	1
12		SS6121610TP	SCREW 3/16-28 L=15.5	1
13		22904155	MAIN SHAFT THRUST COLLAR ASM.	2
14		22904106	MAIN SHAFT THRUST COLLAR	(1)
15		SS8660610TP	SCREW 1/4-40 L=6	(2)
16		10205201	NEEDLE BAR FRAME ROD	1
17		SD0900701TP	HINGE SCREW D=9 H=7	2
18		NS6680320SP	NUT 9/32-28	2
19	#05	21337506	FEED ADJUSTING BASE	1
20	#05	21337704	FEED ADJUSTING BASE COVER	2
21	#05	SS7110910TP	SCREW 11/64-40 L= 8.5	4
22	#05	21337407	SQUARE BLOCK	2
23		21337803	FEED ADJUSTING BASE SUPPORT	2
24		SS8150822TP	SCREW 15/64-28 L=8	2
25	#05	21338306	FELT SUPPORT	1
26	#05	SS7090610SP	SCREW 9/64-40 L=6	2
27		21337902	ECCENTRIC PIN	1
28		SS7090910TP	SCREW 9/64-40 L= 8.5	2
29		21337308	FEED ADJUSTING ROD	1
30		SD0800402TP	HINGE SCREW D= 8 H= 4	1
31		21337605	SPRING	1
32	#03	40011400	FEED ROD (C)	1
33		SS6111610SP	SCREW 11/64-40 L=16	2
34		21337209	FEED ADJUSTING A	1
35		SM6061802TP	SCREW M6 L=18	1
36		21336805	FEED DIAL A	1
37		SS6121860SP	SCREW 3/16-28 L=18	1
38		11009909	FEED REGULATOR SCREW	1
39		RO092270200	RUBBER RING	1
40		22912000	FEED REGULATOR PIN	1
41		22912109	FEED REGULATOR PIN SPRING	1
42		21336656	FEED LINK ASM.	1
43		21336607	FEED LINK	(1)
44		B1418761000	CONNECTING FORKED LINK PIN	(1)
45		CQ202000000	OIL WICK	(0.04)
46		SM8050612TP	SCREW M5X6	(1)
47	#05	21336706	FEED ROD A	1
48		21338207	FEED LINK PIN	1
49		21387402	FELT	1
50		SD1000801SH	HINGE SCREW D=10 H=8	1
51		21336300	BACKWARD FEED LEVER SHAFT	1
52		CS1201010SH	THRUST COLLAR ASM. D=12 W=10	1
53		CS1201011SH	THRUST COLLAR D=12 W=10	(1)
54		SS8660610TP	SCREW 1/4-40 L=6	(2)
55		RE0900000KO	E-RING 9	1
56		21388004	REVERSE FEED ROCK SHAFT	1
57		SS6120930TP	SCREW 3/16-28 L=9	2
58	#01	40019908	FEED DOG(4X2.5)	1
59	#02	40019910	FEED DOG(6X2.5)	1
60		SS4080620TP	SCREW 1/8-44 L=6	2
61	#04	40019911	FEED DOG(2.6X2.2)	1
62		40019926	SPRING HOOK	1
63	#03	40038711	FEED ADJUSTING BASE B	2
64	#03	21407408	FITTING PLATE	2
65	#03	40038712	FELT HOLDER	1
66	#03	SS7110910TP	SCREW 11/64-40 L= 8.5	4
67	#03	SS7110710SP	SCREW 11/64-40 L=7	1
68	#03	40019907	FEED BASE	1
69	#03	21407309	SQUARE BLOCK	2

1..#01FOR DNU-1541 / 2..#02FOR DNU-1541S / 3..#03FOR DNU-1541H / 4..#04OPTIONAL PARTS / 5..#05FOR DNU-1541 DNU-1541S / 6... /

DNU-1541/DNU-1541H/DNU-1541S
 6.HOOK SHAFT & LOWER SHAFT COMPONENTS

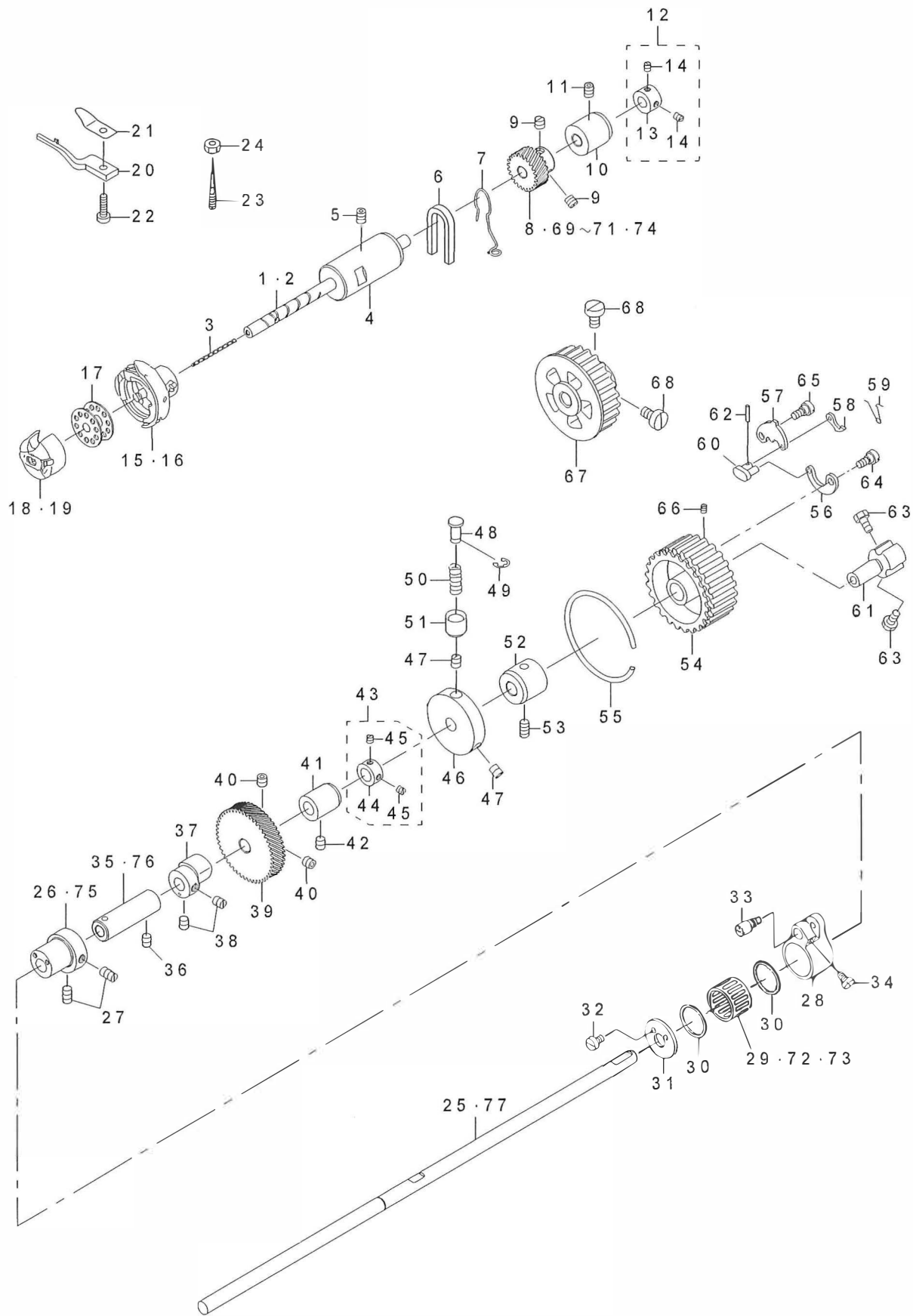

6.HOOK SHAFT & LOWER SHAFT COMPONENTS

No	note	Parts No.	DESCRIPTION	Qty
1	#01	21403506	HOOK SHAFT	1
2	#02	21403605	HOOK SHAFT	1
3		CQ200000000	OIL WICK	0.1
4		B1802141H00A	DRIVING SHAFT BUSHING FRONT	1
5		SS8150822TP	SCREW 15/64-28 L=8	1
6		B1155141H00	OIL PIEP	1
7		21407804	FELT SUPPORT	1
8		21404009	HOOK SHAFT GEAR A	1
9		SS8660610TP	SCREW 1/4-40 L=6	2
10		B1803141H00	BUSHING INTERMEDIATE	1
11		SS8150822TP	SCREW 15/64-28 L=8	1
12		CS0791010SH	THRUST COLLAR ASM. D=7.94 W=10	1
13		CS0791016SH	THRUST HOLDER D=7.94 W=10	(1)
14		SS8110422TP	SCREW 11/64-40 L=4	(2)
15	#01	B1830241HA0	HOOK ASM.	1
16	#02	B1830241SA0	HOOK ASM.	1
17		B9117201000	BOBBIN	1
18	#01	B1837241H00	BOBBIN CASE	1
19	#02	B1837241S00	BOBBIN CASE	1
20		11038809	BOBBIN CASE HOLDER	1
21		B1829241H00	THREAD PRESSER PLATE	1
22		SS6111620SP	SCREW 11/64-40 L=16.0	1
23		B1834512000A	OIL ADJUSTING SCREW	1
24		NS6110530SP	NUT 11/64-40	1
25		21402409	LOWER SHAFT	1
26		21405105	FEED DRIVING CAM	1
27		SS8151150TP	SCREW 15/64-28 L=10.5	2
28		23618200	FEED DRIVING BASE ARM	1
29	#03	SB32000060A	BEARING	1
30		23618101	FEED DRIVING CAM THRUST BUSH	2
31		21405303	FEED DRIVING CAM PLATE	1
32		SS6090620TP	SCREW	2
33		23618408	FEED DRIVING BASE SHAFT	1
34		SS7110740TP	SCREW 11/64-40 L=7	1
35		21402508	LOWER SHAFT FRONT METAL	1
36		SS8150710TP	SCREW 15/64-28 L=7	1
37	#02	21404405	OPENER CAM	1
38	#02	SS8150710TP	SCREW 15/64-28 L=7	2
39		21402706	LOWER SHAFT GEAR	1
40		SS8660612TP	SCREW 1/4-40 L=6	2
41		21402607	LOWER SHAFT INNER METAL	1
42		SS8150710TP	SCREW 15/64-28 L=7	1
43		CS0950810SH	THRUST COLLAR ASM. D=9.5 W=8	1
44		CS0950816SH	THRUST COLLAR D=9.5 W=8	(1)
45		SS8110410TP	SCREW 11/64-40 L= 3.5	(2)
46	#02	21403001	SAFETY CLUTCH DISC	1
47	#02	SS8150710TP	SCREW 15/64-28 L=7	2
48	#02	B1312563000A	SAFETY CLUTCH PUSH BUTTON	1
49	#02	RE0500000K0	E-RING	1
50	#02	B1639051000	SPRING	1
51	#02	B1313055000	SAFETY CLUTCH KNOB SLEEVE	1
52		21402805	LOWER SHAFT BACK METAL	1
53		SS8150710TP	SCREW 15/64-28 L=7	1
54	#02	21333505	LOWER SPROCKET	1
55	#02	B1214019000	SPROCKET RING	1
56	#02	B1305055000A	SAFETY CLUTCH SPRING	1
57	#02	B1307055000	SAFETY CLUTCH HOOK	1
58	#02	B1308055000	SAFETY CLUTCH COUNTER-HOOK	1
59	#02	B1309055000	COUNTER-HOOK SPRING	1
60	#02	B1310055000	SAFETY CLUTCH SMALL LINK	1
61	#02	10503605	SAFETY BASE	1
62	#02	B1314055000	SAFETY CLUTCH SMALL LINK PIN	1
63	#02	SS6661110SP	SCREW 1/4-40 L=11	2
64	#02	SD0640322TP	HINGE SCREW D= 6.35 H= 3.2	1
65	#02	SD0640322TP	HINGE SCREW D= 6.35 H= 3.2	1
66	#02	SS8090540SP	SCREW 9/64-40 L=5	1
67	#01	22623201	SPROCKET WHEEL	1
68	#01	SS6661110SP	SCREW 1/4-40 L=11	2
69	#03	21404207	HOOK SHAFT GEAR C	1
70	#03	21404108	HOOK SHAFT GEAR B	1
71	#03	21404306	HOOK SHAFT GEAR D	1
72	#03	SB32000060B	BEARING	1
73	#03	SB32000060C	BEARING	1
74	#03	21403902	HOOK SHAFT GEAR Z	1
75	#04	21405501	FEED DRIVING CAM	1
76	#04	40026828	LOWER SHAFT FRONT METAL ASM.	1
77	#01	40082634	LOWER SHAFT	1

1...#01FOR DNU-1541·DNU-1541H / 2...#02FOR DNU-1541S / 3...#03SELECTIVE PARTS / 4...#04FOR DNU-1541H / 5... /

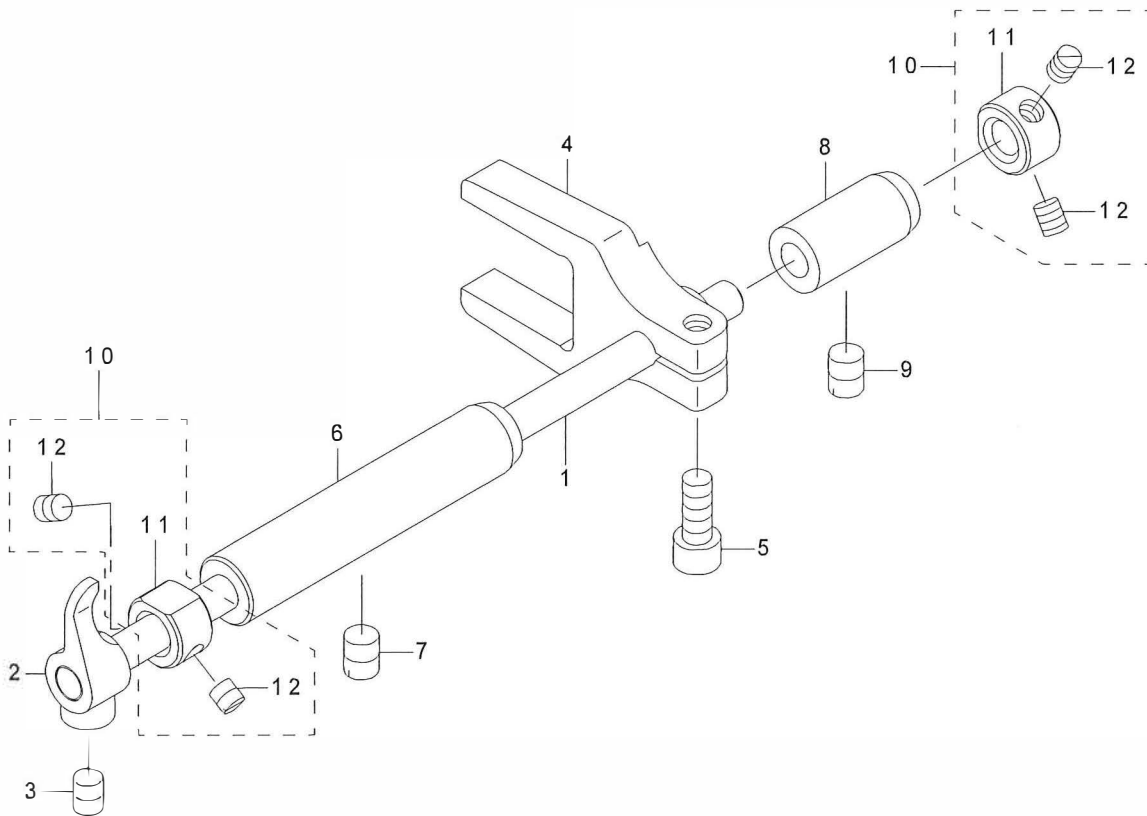

DNU-1541/DNU-1541H/DNU-1541S
 7.OPENER COMPONENTS (FOR DNU-1541S)

Part No	Note	DESCRIPTION	Qty
1	21404504	OPENER SHAFT	1
2	B1805241H00	OPENER	1
3	SM8050602TP	SCREW M5 L=6	1
4	B1806241H00	OPENER ARM	1
5	SM6051202TP	SCREW M5X0.8 L=12	1
6	21404603	BUSHING FRONT	1
7	SS8150710TP	SCREW 15/64-28 L=7	1
8	B1810241H00	OPENER SHAFT REAR METAL	1
9	SS8150710TP	SCREW 15/64-28 L=7	1
10	CS0640860SH	THRUST COLLAR ASM. D=6.35 W=8	2
11	CS0640863SH	THRUST COLLAR D=6.35 W=8	(2)
12	SS8110510SP	SCREW 11/64-40 L=5	(4)

1... /

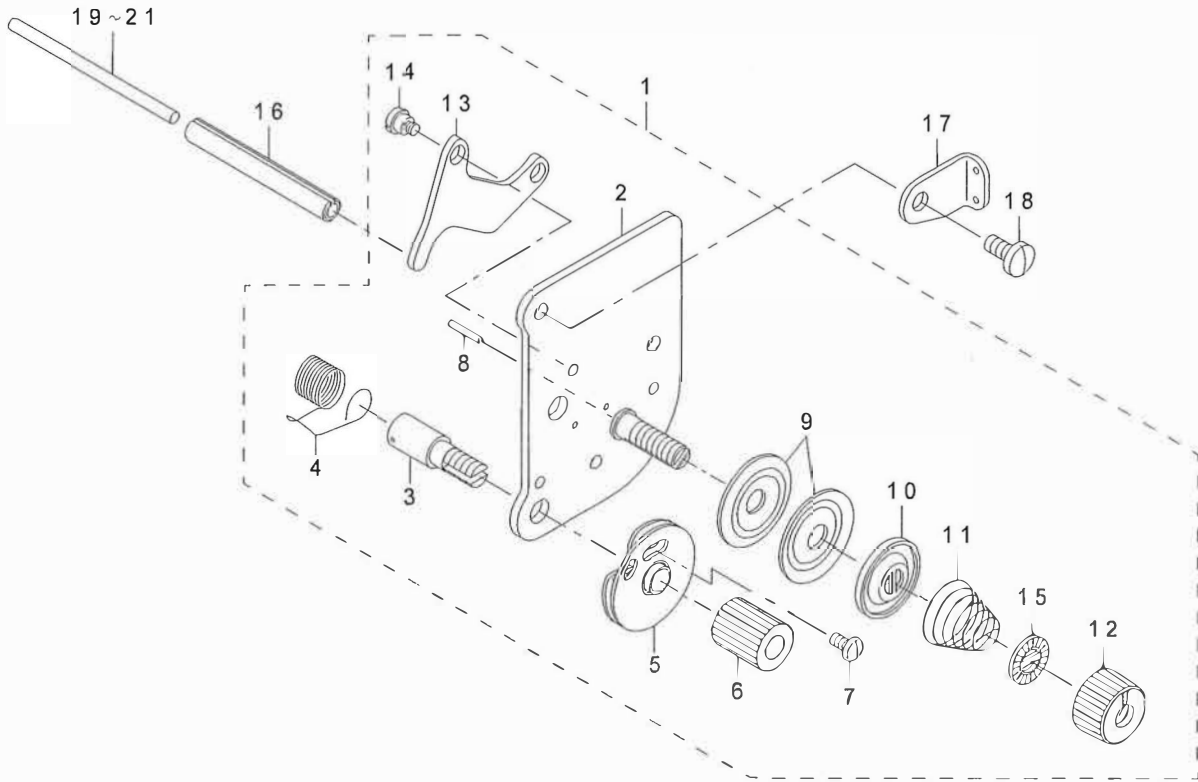

8.THREAD TENSION COMPONENTS

No	note	Parts No.	DESCRIPTION	Qty
1		40103059	THREAD TENSION ASM.	1
2		40103060	THREAD POST BASE COMPL.	(1)
3		10320109	SCREW STUD	(1)
4		B3128051000	THREAD TAKE-UP SPRING A	(1)
5		B31370510A0	TAKE-UP SPRING GUIDE DISC ASM.	(1)
6		10320208	THRED TENSION STUD NUT	(1)
7		SS4080620TP	SCREW 1/8-44 L=6	(1)
8		B3127051000	TENSION RELEASE P'IN SHORT	(1)
9		13138201	THREAD TENSION DISK	(2)
10		22617906	THREAD TENSION DISK PRESSER	(1)
11		B3129053000	TENSION SPRING	(1)
12		22921308	THREAD TENSION NUT	(1)
13		B3134521000	TENSION RELEASE LEVER	(1)
14		SD0470281SP	HINGE SCREW D=4.7 H=2.8	(2)
15		22921407	ROTATION STOPPER	(1)
16		PS0600502KP	SPRING PIN	1
17		21409909	GUIDE PLATE	1
18		SS7110910TP	SCREW 11/64-40 L= 8.5	2
19		21348206	TENSION RELEASE BAR	1
20	#01	10321107	TENSION RELEASE BAR	1
21	#01	23006406	TENSION RELEASE BAR	1

1...#01SELECTIVE PARTS / 2... /

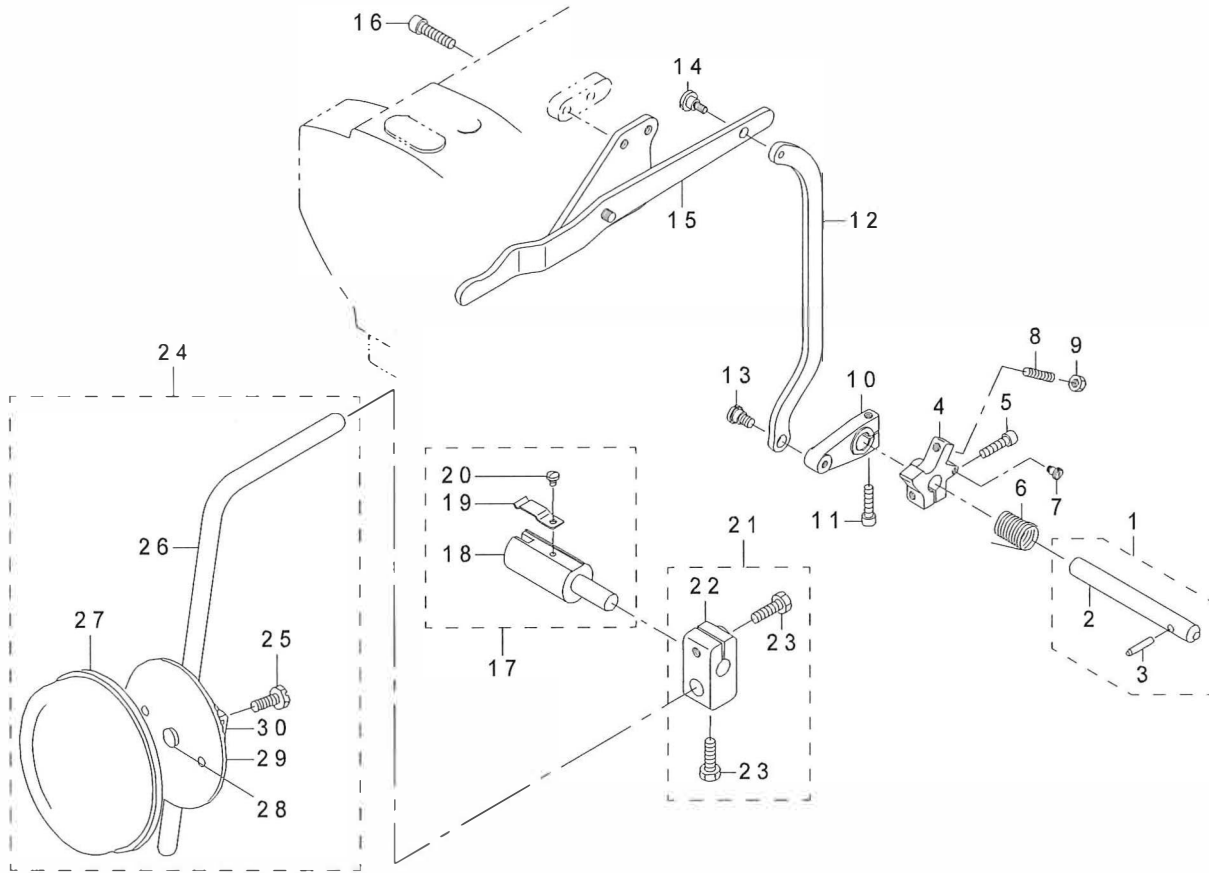

No	note	Parts No.	DESCRIPTION	Qty
1		21406053	KNEE LIFTER SHAFT ASM.	1
2		21406004	KNEE LIFTER SHAFT	(1)
3		21342605	KNEE LIFTER SHAFT PIN	(1)
4		21405808	KNEE LIFTER SPRING RACK	1
5		SM6052002TP	SCREW M5 L=20	1
6		21405907	KNEE LIFTER SHAFT SPRING	1
7		SD0450401SP	HINGE SCREW D= 4.5 H= 4	1
8		SM8052502TP	SCREW M5X0.8 L=25	1
9		NM6050001SD	NUT M5X0.8	1
10		21405709	KNEE LIFTER ARM	1
11		SM6052002TP	SCREW M5 L=20	1
12		21405600	KNEE LIFTER CONNECTING PLATE	1
13		SD0790451SP	HINGE SCREW D= 7.94 H= 4.5	1
14		SD0700451TP	HINGE SCREW D=7 H=4.5	1
15		21343355	KNEE LIFTER LEVER ASM.	1
16		SM6062502TP	SCREW M6 L=25	2
17		22863252	KNEE LIFTER JOINT ASM.	1
18		22863203	KNEE LIFTER JOINT	(1)
19		B3428521000	PRESSER SPRING	(1)
20		SS7090510SP	SCREW 9/64-40 L= 4.6	(1)
21		22932453	BRACKET ASM.	1
22		22932404	BRACKET	(1)
23		22934707	SCREW	(2)
24		21343157	KNEE PRESS PLATE ASM.	1
25		SM9061203SE	SCREW M6 L=12	(1)
26		21343108	KNEE PRESS LEVER	(1)
27		22934509	KNEE PAD PLATE COVER	(1)
28		22934400	KNEE PAD PLATE RUBBER	(1)
29		22934202	KNEE PAD PLATE	(1)
30		22934301	KNEE PAD PLATE SUPPORT	(1)

1... /

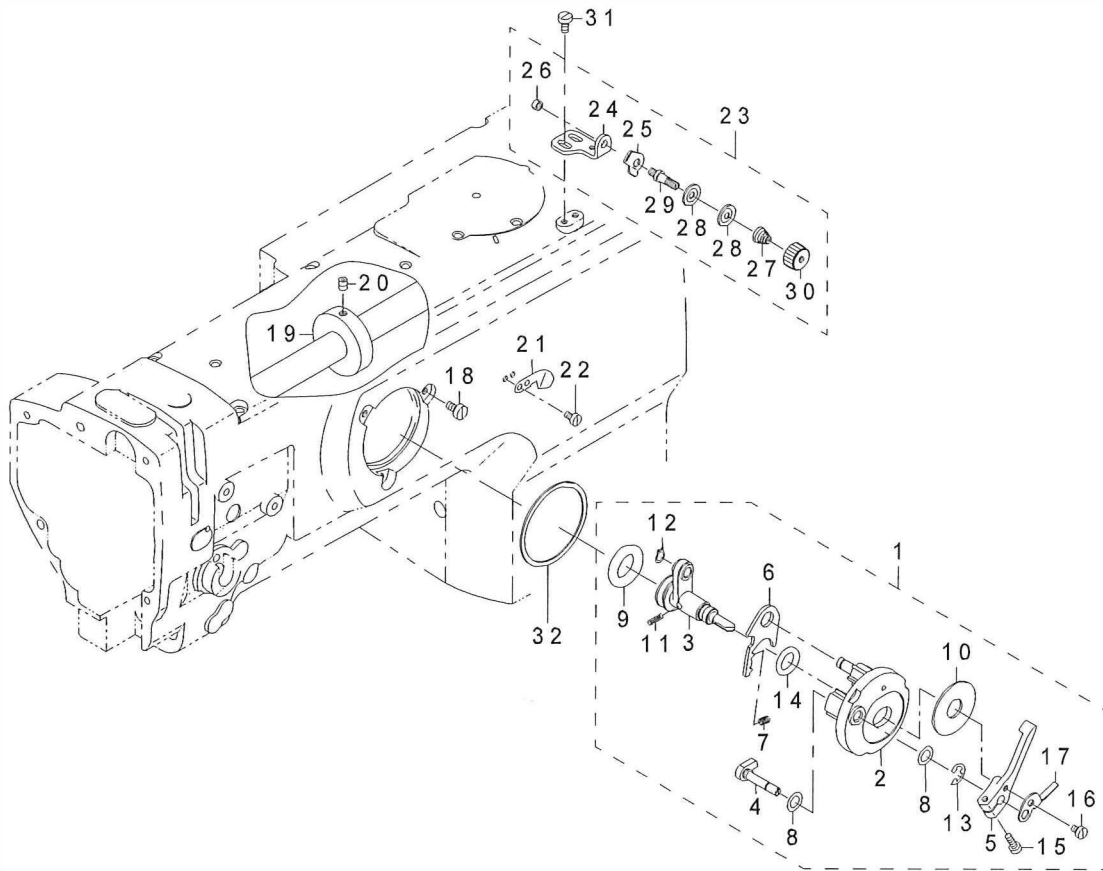

DNU-1541/DNU-1541H/DNU-1541S
 10.LOWER THREAD WINDER MECHANISM COMPONENTS

No	note	Parts No.	DESCRIPTION	Qty
1		21357967	BOBBIN DEVICE ASM.	1
2		22537658	BOBBIN FITTING BASIS COMPL.	(1)
3		21357959	BOBIN SHAFT COMPL.	(1)
4		22538151	BOBBIN CAM SHAFT COMPL.	(1)
5		23636202	BOBBIN LEVER	(1)
6		21356001	ADJUSTING PLATE	(1)
7		B152989000CA	PRESSUR FOOT SPRING	(1)
8		10618304	VERTICAL ROLLER WASHER	(2)
9		21358205	BOBBIN FRICTION GEAR	(1)
10		B3205210000	CUSHION	(1)
11		B1148555000	SPRING	(1)
12		RC0560711KP	RETAINING RING	(1)
13		RE0500000K0	E-RING	(1)
14		RO092270200	RUBBER RING	(1)
15		SS7091410SP	SCREW 9/64-40 L=13.5	(1)
16		SS6090520SP	SCREW 9/64-40 L= 5.0	(1)
17		14512503	BOBBIN ADJUSTING PLATE	(1)
18		SS6110810TP	SCREW 11/64-40 L=8	3
19		10704807	BOBBIN FRICTION WHEEL	1
20		SM8050602TP	SCREW M5 L=6	2
21		10502300	THREAD CUTTER	1
22		SS6090620TP	SCREW	2
23		21355755	LOWER THREAD GUIDE ASM.	1
24		21355706	FITTING BASE	(1)
25		D3162555B00	THREAD GUIDE	(1)
26		NS6110310SP	NUT 11/64-40	(1)
27		22945505	THREAD TENSION SPRING	(1)
28		40113092	THREAD TENSION DISK	(2)
29		21378708	THREAD TENSION POST	(1)
30		22945703	THREAD TENSION NUT	(1)
31		SM6040800SP	SCREW	2
32		22538706	PACKING	1

1... /

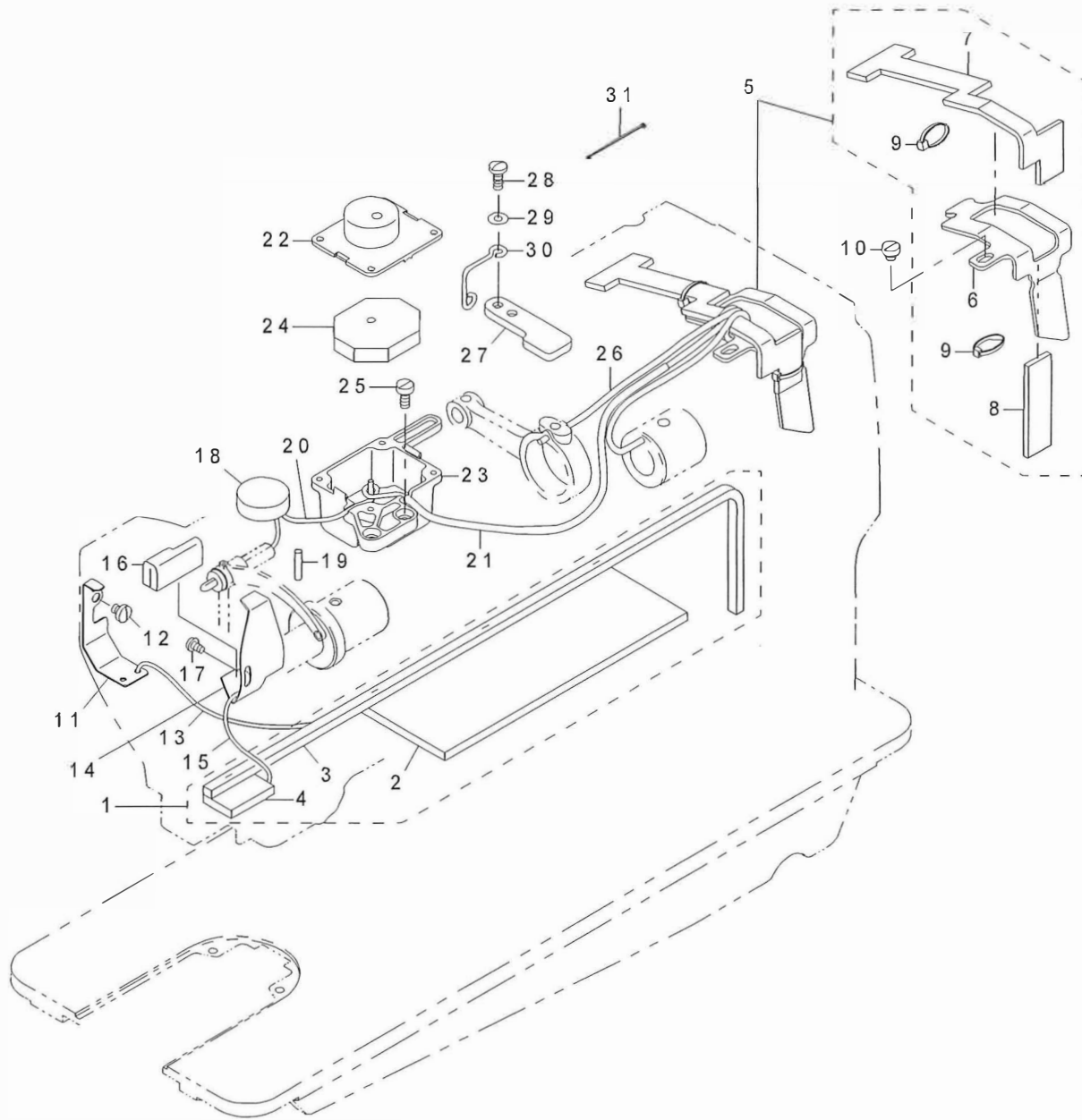

No	note	Parts No.	DESCRIPTION	Qty
1		21345756	ARM ONCE THROUGH OIL FELT ASM.	1
2		21345707	ARM ONCE THROUGH FELT A	1
3		21345806	FELT B	1
4		21345905	FACE ONCE THROUGH FELT	1
5		21346358	FELT SUPPORT ASM.	1
6		21346309	FELT	(1)
7		21346507	FEED CHANGE FELT	(1)
8		21346408	FELT	(1)
9		EA9500B0000	CLIP CV-70S	(2)
10		SS6110480SP	SCREW 11/64-40 L=4.3	1
11		21340708	UPPER FEED OIL BAR PLATE	1
12		SS7110510SP	SCREW 11/64-40 L=5	1
13		CQ202000000	OIL WICK	0.2
14		21347000	TAKE-UP OIL PLATE	1
15		CQ202000000	OIL WICK	0.25
16		21347208	TAKE-UP LUBRICATION FELT	1
17		SS3090610SP	SCREW 9/64-40 L=6	1
18		21346002	FELT	1
19		B1412051000	FELT	1
20		CQ252000000	OIL WICK	0.3
21		BT0500300EA	OIL TUBE	0.25
22		21407507	OIL TANK A	1
23		21407606	OIL TANK B	1
24		21407705	FELT	2
25		SS6111010SP	SCREW 11/64-40 L= 9.5	2
26		CQ202000000	OIL WICK	0.2
27		21339700	UPPER FEED STOPPER PLATE (B)	1
28		SS7111120TP	SCREW	2
29		WP0450801SD	WASHER 4.5X10X0.8	1
30		22620504	OIL WICK HOLDER	1
31		EA9500B0000	CABLE BAND	1

1... /

DNU-1541/DNU-1541H/DNU-1541S
12.BELT COVER & OIL RESERVOIR COMPONENTS

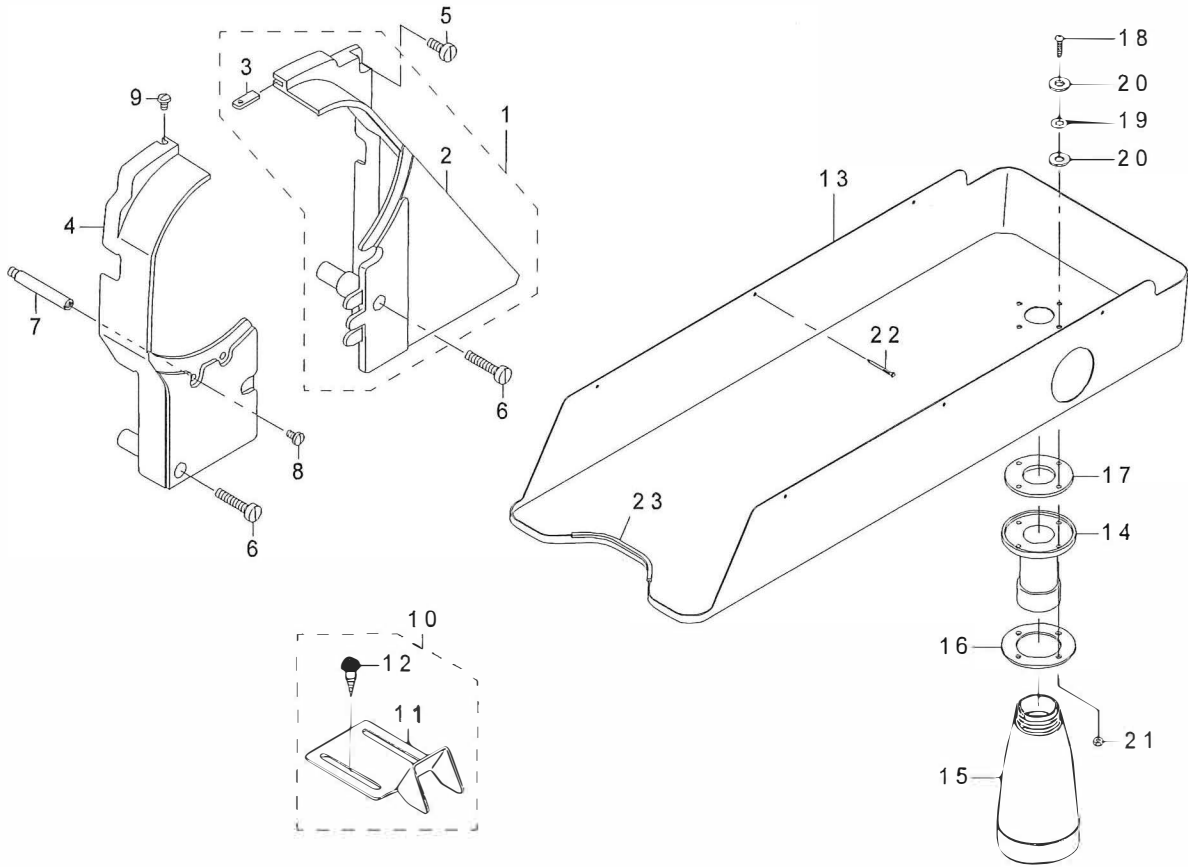

DNU-1541/DNU-1541H/DNU-1541S
 12.BELT COVER & OIL RESERVOIR COMPONENTS

No	note	Parts No.	DESCRIPTION	Qty
1		21351150	BELT COVER ASM. (RIGHT)	1
2		21351101	BELT COVER (RIGHT)	(1)
3		21351002	BELT COVER AUXILIARYPLATE	(1)
4		21351200	BELT COVER (LEFT)	1
5		SS6151440SP	SCREW 15/64-28 L=14	1
6		SS6153040SP	SCREW 15/64-28 L=30	2
7		D8232241E00	BELT COVER SUPPORT A	1
8		SS7110840SP	SCREW 11/64-40 L=7.8	1
9		SS5110740TP	SCREW 11/64-40 L= 6.5	1
10		10755254	BELT COVER C ASM. (FOR JE)	1
11		10755205	BELT COVER C(JE)	(1)
12		SK3482500SC	WOOD SCREW D=4.8 L=25	(2)
13		21413000	OIL RESERVOIR	1
14		B8202205000	OIL MANAGEMENT	1
15		B9121012000	OIL CAN	1
16		21379003	OIL MANAGEMENT WASHER	1
17		B8112220000	OIL SEAL	1
18		SM3031401SE	SCREW M3X0.5 L=14	4
19		WP0320501SC	WASHER M3	4
20		10748101	OIL REMOVING SETSCREW PACKING	8
21		NM6030001SC	NUT M3	4
22		10539906	SET NAIL	6
23		MAV02130000	EDGING	1

1... /

13.THREAD STAND COMPONENTS

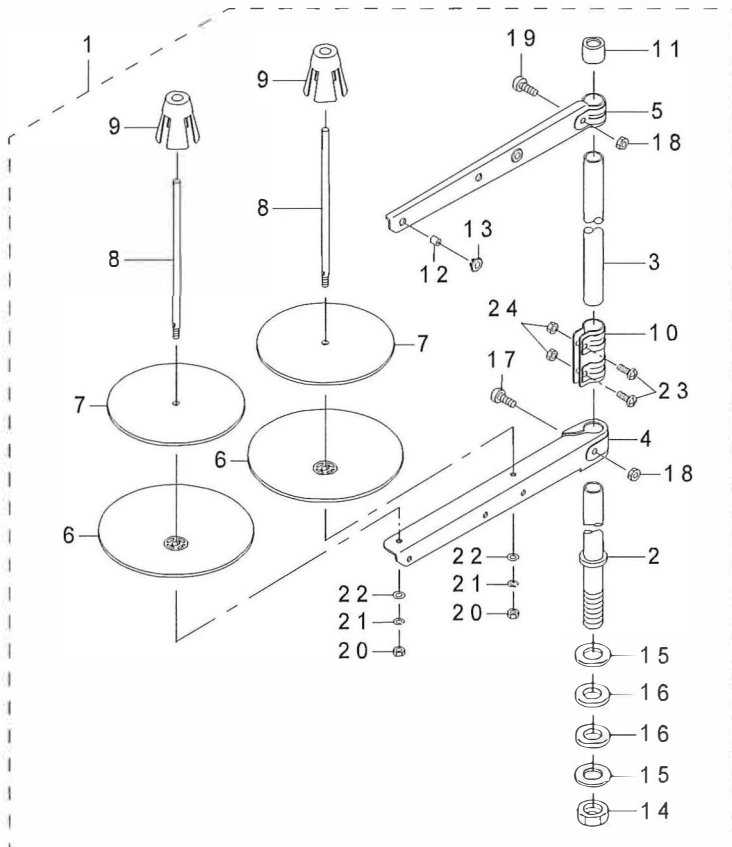

No	note	Parts No.	DESCRIPTION	Qty
1		40096354	THREAD STAND ASM.	1
2		40085784	SPOOL REST ROD LOWER	(1)
3		40085785	SPOOL REST ROD UPPER	(1)
4		40085786	SPOOL REST ARM LOWER	(1)
5		40085787	SPOOL REST ARM UPPER	(1)
6		40085788	SPOOL REST	(2)
7		40085789	SPOOL REST CUSHION	(2)
8		40085790	SPOOL PIN	(2)
9		40085791	SPOOL RETAINER	(2)
10		40085792	SPOOL REST ROD JOINT	(1)
11		40085793	SPOOL REST ROD RUBBER CAP	(1)
12		40085794	THREAD GUIDE	(2)
13		40085795	THREAD GUIDE BUSHING	(2)
14		40096325	SPOOL REST ROD NUT	(1)
15		WP1612616SE	WASHER 16X30X2.6	(2)
16		40085796	SPOOL REST ROD RUBBER CUSHION	(2)
17		40096326	SPOOL REST ARM LOWER SCREW	(1)
18		NM6050001SE	NUT M5	(2)
19		40096327	SPOOL REST ARM UPPER SCREW	(1)
20		NM6050001SE	NUT M5	(2)
21		WS0510002KN	SPRING WASHER M5	(2)
22		WP0531001SC	WASHER M5	(2)
23		SM4051405SE	SCREW M5 L=14	(2)
24		NM6050001SE	NUT M5	(2)

1... / 2...undefined / 3...undefined / 4...undefined / 5...undefined / 6...undefined / 7...undefined / 8...undefined / 9...undefined / 10...undefined / 11...undefined / 12...undefined / 13...undefined / 14...undefined / 15...undefined / 16...undefined / 17...undefined / 18...undefined / 19...undefined / 20...undefined / 21...undefined / 22...undefined / 23...undefined / 24...undefined / 25...undefined / 26...undefined / 27...undefined / 28...undefined / 29...undefined / 30...undefined / 31...undefined / 32...undefined / 33...undefined / 34...undefined / 35...undefined / 36...undefined / 37...undefined / 38...undefined / 39...undefined / 40...undefined / 41...undefined / 42...undefined / 43...undefined / 44...undefined / 45...undefined / 46...undefined / 47...undefined / 48...undefined / 49...undefined / 50...undefined / 51...undefined / 52...undefined / 53...undefined / 54...undefined / 55...undefined / 56...undefined / 57...undefined / 58...undefined / 59...undefined / 60...undefined / 61...undefined / 62...undefined / 63...undefined / 64...undefined / 65...undefined / 66...undefined / 67...undefined / 68...undefined / 69...undefined / 70...undefined / 71...undefined / 72...undefined / 73...undefined / 74...undefined / 75...undefined / 76...undefined / 77...undefined / 78...undefined /