

# ARTISAN®

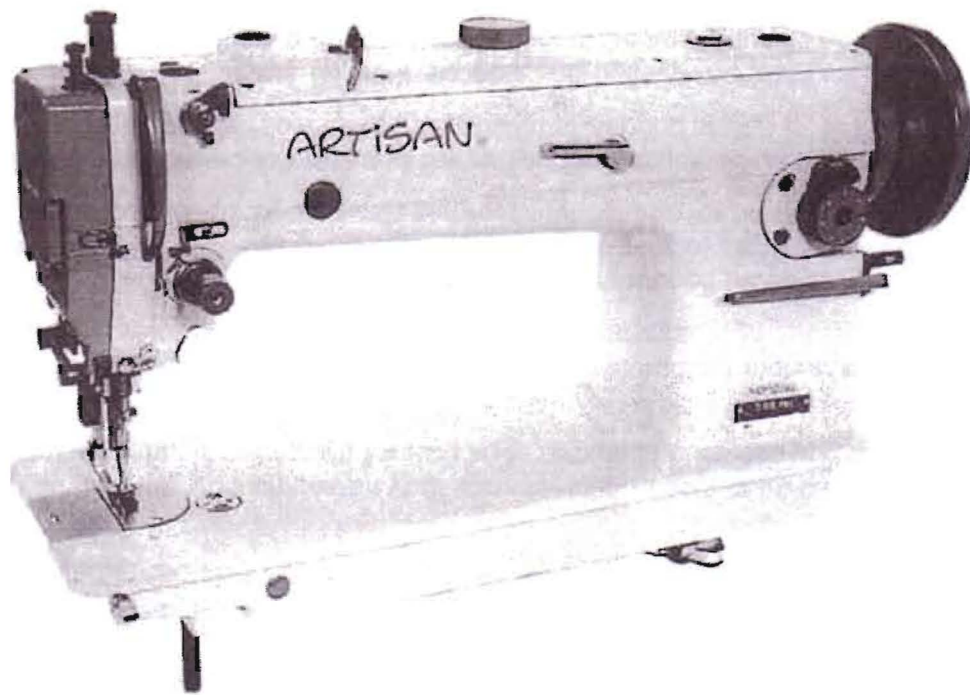

**797 AB-800**

**797 AB-8001**

**797 AB-8001 LTHR**

**Operators Manual  
and  
Spare Parts List**

---

# CONTENTS

## 1. Instruction Manual

1、SAFETY PRECAUTIONS.....	3
2、PRECAUTIONS BEFORE STARTING OPERATION.....	3
3、PRECAUTIONS FOR OPERATING CONDITIONS.....	3
4、SPECIFICATIONS.....	4
5、POWER CABLE CONNECTION.....	4
6、CONNECTION OF CONTROL BOX.....	5
7、INSTALLING THE BELT.....	6
8、ADJUSTMENT OF NEEDLE BAR STOP POSITION.....	6
9、INSTALLING THE KNEE LIFTER.....	7
10、LUBRICATION.....	7
11、CONDITION OF OIL LUBRICATION.....	7
12、ADJUSTMENT OF THE HOOK LUBRICATION.....	8
13、ADJUSTMENT OF OIL PUMP.....	8
14、PERIODICAL CLEANING.....	8
15、HANDLING INSTRUCTIONS (MOTOR AND CONTROL BOX).....	9
16、INSTALLATION OF BELT COVER.....	9
17、HOW TO WIND THE LOWER THREAD.....	10
18、HOW TO ATTACH A NEEDLE.....	10
19、HOW TO ROUTE THE UPPER THREAD.....	11
20、ADJUSTMENT OF STITCH LENGTH AND REVERSE SEWING.....	11
21、ADJUSTING THE THREAD TENSION.....	11
22、UPPER THREAD TENSION.....	12
23、LOWER THREAD TENSION.....	12
24、ADJUSTMENT OF PRESSER PRESSURE.....	12
25、FEED DOG HEIGHT.....	13
26、ADJUSTMENT OF FEED DOG INCLINATION.....	13
27、ADJUSTMENT OF STITCH LENGTH AND FORWARD/BACKWARD.....	13
28、PRESSER BAR LIFTER.....	14
29、ADJUSTMENT OF WALKING FOOT AND PRESSER FOOT.....	14
30、ADJUSTMENT OF FEED TIMING.....	16
31、ADJUSTMENT OF THREAD TRIMMER MECHANISM.....	16

## 2. Parts Catalog

A. ARM BED AND ITS ACCESSORIES.....	20
B. SEWING MECHANISM.....	23
C. SEWING MECHANISM & FEED ROCK LOWER SHAFT.....	26
D. STITCH LENGTH MECHANISM.....	29
E. UPPER FEED ROCK SHAFT MECHANISM.....	32
F. UPPER FEED LIFTING ROCK SHAFT MECHANISM.....	34
G. PRESSER FOOT MECHANISM.....	37
H. KNIFE ACTUATING MECHANISM.....	39

---

I. TOUCH BACK & DETECTOR MECHANISM.....	42
J. OIL LUBRICATION MECHANISM.....	44
K. ACCESSORIES.....	46

---

## **1、 Safety precautions :**

- 1) When turning the power on, keep your hands and fingers away from the area around/under the needle and the area around the pulley.
- 2) Power must be turned off when the machine is not in use, or when the operator leaves the seat.
- 3) Power must be turned off when tilting the machine head, installing or removing the “V” belt, adjusting the machine, or when replacing.
- 4) Avoid placing fingers, hairs, bars etc., near the pulley, “V” belt, bobbin winder pulley, or motor when the machine is in operation.
- 5) Do not insert fingers into the thread take-up cover, under/around the needle, or pulley when the machine is in operation.
- 6) If a belt cover, finger guard, eye guard are installed, do not operate the machine without these safety devices.

## **2、 Precautions before starting operation:**

- 1) Never operate the machine before filling the machine’s oil pan.
- 2) When a new sewing machine is first turned on, verify the rotational direction of the pulley with the power on.
- 3) Verify the voltage and phase (single or three) with those given on the machine nameplate.

## **3、 Precautions for operating conditions:**

- 1) Avoid using the machine at abnormally high temperatures (35°C or higher) or low temperatures (5°C or lower) .
- 2) Avoid using the machine in dusty conditions.

#### 4. Specifications:

Specifications		Model	
		GC0388-D	GC0388
Material weight		Heavy	
Max. sewing speed		2,000 rpm	
Stitch length		0—8.0 mm	
Needle bar stroke		38.0 mm	
Thread take-up lever stroke		73.0 mm	
Alternating movement		2.0-5.0 mm	
Walking foot alternate operating system		Dial	
Feed dog height		1.0 mm	
Needle		DP×17 22#	
Presser foot stroke	By hand	6.0 mm	
	By knee	16.0 mm	
Hook		Fully rotating automatic lubrication (for thread trimmer), Large	Fully rotating automatic lubrication, Large
Lubrication system		Automatic	
Thread trimmer		○	×
Touch back		○	

#### 5. Power cable connection:

##### 1) Connection to power supply:

Each connector(plug) should be completely set in the corresponding receptacle of the control box after checking the connector shape and mating direction.

(1) When a three-phase motor is used, connect “U” phase to the red lead, “V” phase to the white lead, “W” phase to the black lead. Motor rotation direction depends on the internal switch setting in the control box.

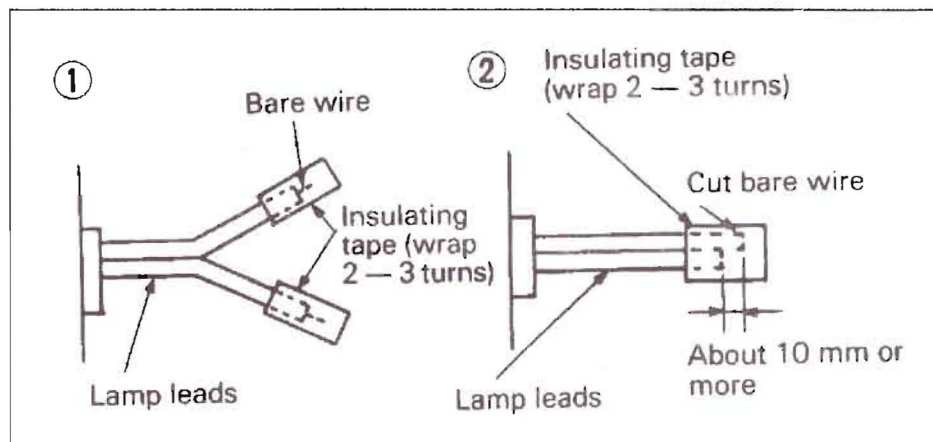

Fig.1

Fig.2.

**Note: The green wire must be connected to the ground terminal in order to properly ground the motor.**

(2) The appropriate power fuse capacity is as follows:

Three-phase power source: 200-240V : 10A

Single-phase power source: 100-120V : 15A

2) Lamp leads

(1) When installing a work lamp (6V, 15-20W), remove the insulation from the leads at the back of the control box, strip the wire and connect them appropriately insulating the connections using insulating tape.

**Note: The power switch must be turned off before connecting the lamp.**

(2) When a work lamp is not used, the lamp lead ends must be insulated as shown in Fig.(1) or Fig.(2) so that the two leads do not shortcircuit. If this is not done, the transformer in the control box will be burned.

**Note: The work lamp must not be connected in parallel to any heater, such as a foot warmer.**

3) Direction of rotation

To change motor rotation direction, remove the rubber cap (see Fig. 3) at the bottom left of the motor front cover and push the internal direction selector switch.

Rotation direction has been set to counterclockwise as seen from the motor pulley before shipment.

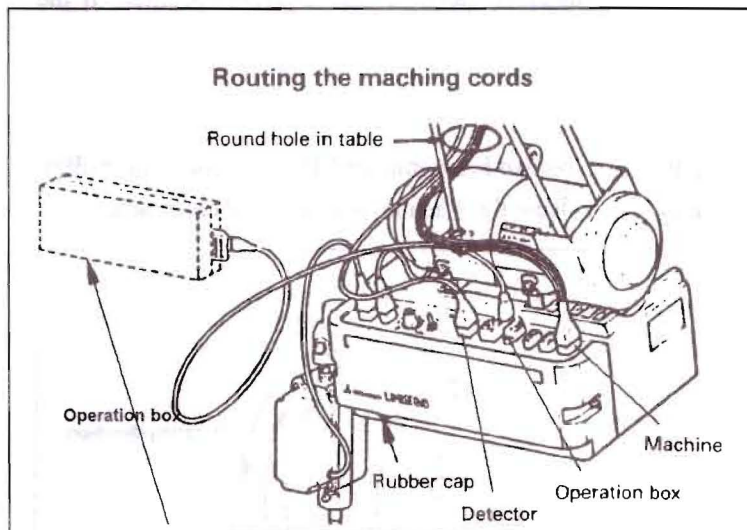

Fig.3

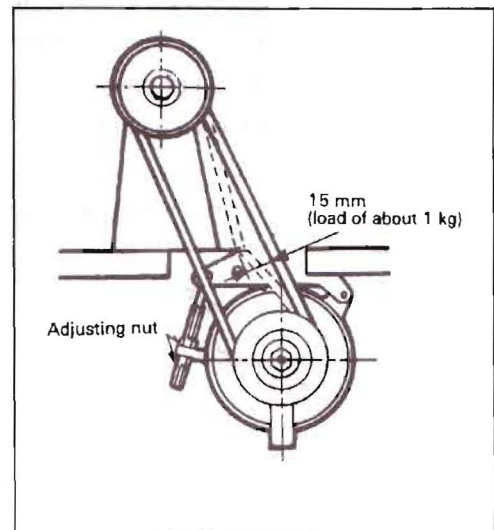

Fig.4

## 6. Connection of control box (Fig.3):

The control box should be connected as shown Fig.3.

**Note:**

(1) Be sure to turn the power switch off before connecting or disconnecting the connectors.

(2) The combination of the machine heads with the motor control panels are specified below. Use special care to ensure the correct combination when replacing the machine head or motor control panel.

Machine head model	Control box model
GC0388-D	XC-AM-A1020
	XC-AM-B2020

## 7、 Installing the belt (Fig.4):

- 1) Use a V-belt for sewing machine use, type M.
- 2) To adjust the belt tension, change the motor height by turning the tension adjust nuts so that the belt sinks about 15mm when depressed by hand at the center of the belt span.

If the tension is too low, the speed may not be consistent in the low or medium range, or the needle may not stop in the proper position. If the tension is too high, the motor bearings will deteriorate more rapidly.

## 8、 Adjustment of needle bar stop position(Fig5, Fig6, Fig7):

- 1) Adjustment of "UP" position

When the pedal is kicked down by heel to cut the thread, the machine stops in the "UP" position. If the marks deviate more than 3mm, adjust as follows:

- (1) Disconnect the plug (12 pins) from the control panel;
- (2) Run the machine and stop in the "UP" position;
- (3) While holding the pulley, insert the adjusting tool into the two holes marked "A", then rotate the pulley.

- 2) Adjustment of "DOWN" position

When the pedal is returned to the neutral position, the machine stops in the "DOWN" position. If the marks deviate more than 3mm, adjust as follows:

- (1) Disconnect the plug (12 pins) from the control panel;
  - (2) Run the machine and stop in the "DOWN" position;
  - (3) While holding the pulley, insert the adjusting tool into the two holes marked "B", then rotate the pulley.
- 3) Confirm the stop operation then the plug (12 pins) coming from the machine head into the receptacle.

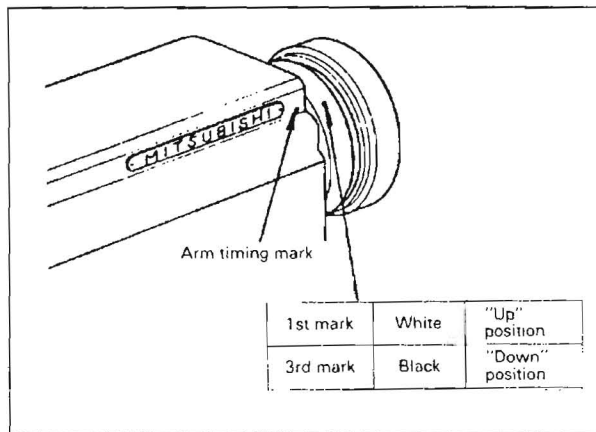

Fig.5

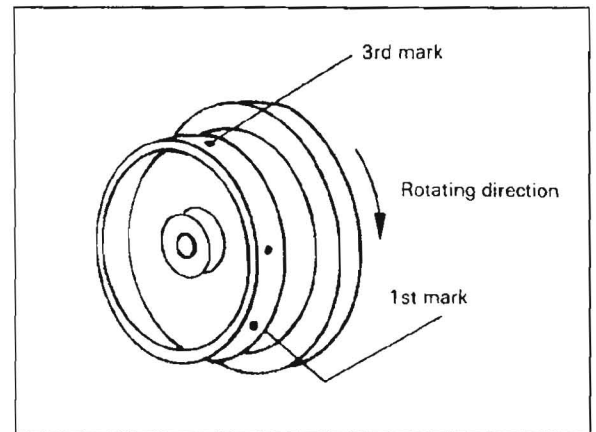

Fig.6

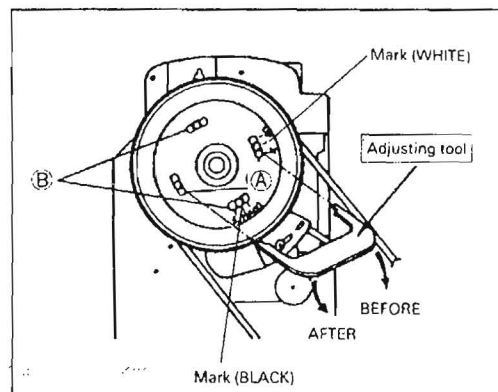

Fig.7

## 9、 Installing the knee lifter (Fig.8) :

- 1) Pull out the knee lifter shafts (on the right and left) as far as possible, and properly set them.
- 2) Install the drive arm on each shaft.
- 3) Set a link between the right and left drive arms to connect them.
- 4) Install the knee lifter lever on the left drive arm.

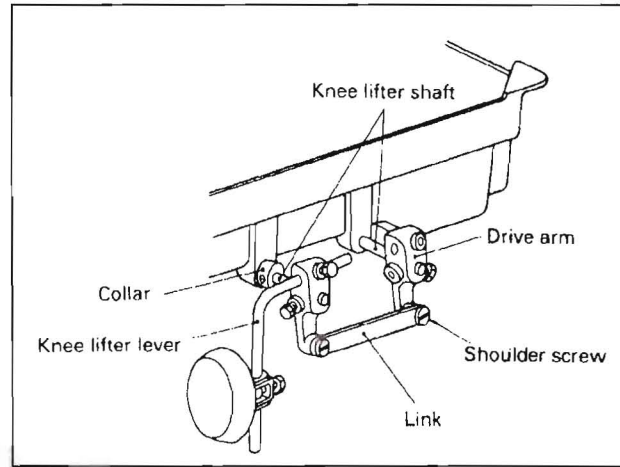

Fig.8

## 10、 Lubrication (Fig.9):

Pour oil up to position "A" of the oil tank.

During operation, check the oil level periodically, and in cases where the oil level is below position "B", replenish the oil supply up to position "A".

Use white spindle oil.

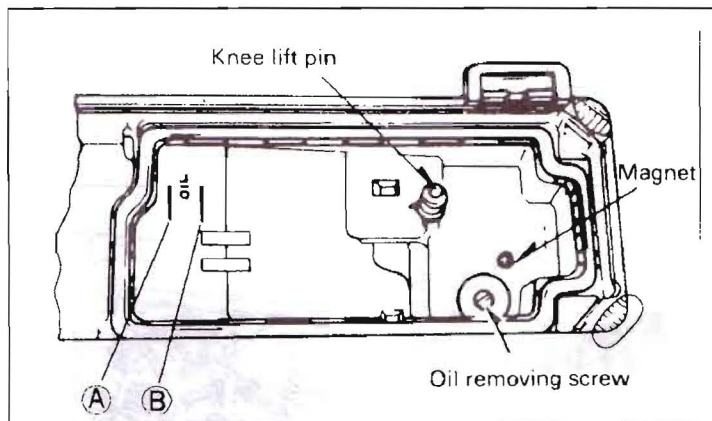

Fig.9

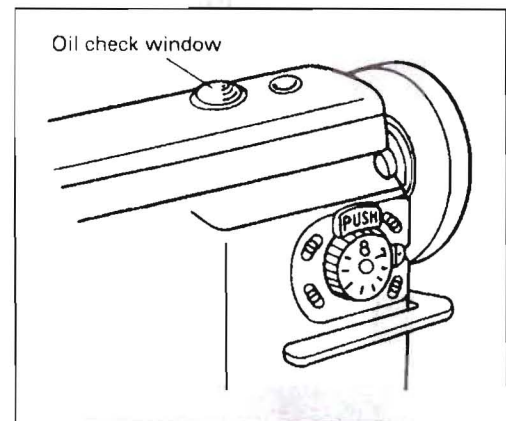

Fig.1

## 11、 Condition of oil lubrication (Fig.10):

While operating the machine, check the condition of oil lubrication through the oil check window.



## 12、 Adjustment of the hook lubrication (Fig.11):

Adjustment can be done by turning screw "A".

(1) When the screw has been fully tightened ..... Maximum

(3) When the screw has been fully loosened ..... Maximum

**Note:** After adjustment of this screw, the machine should be operated for at least 30 seconds, then check the oil mist from the hook.

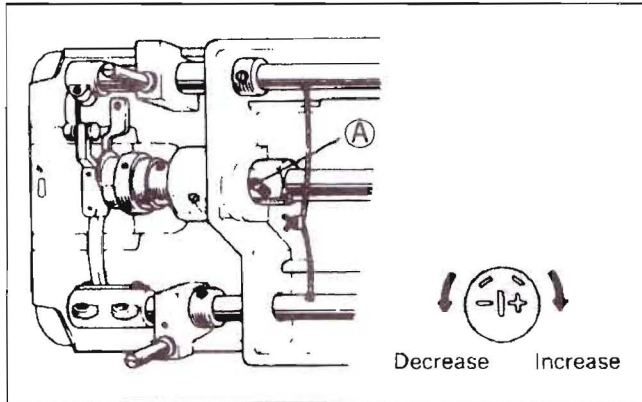

Fig.11

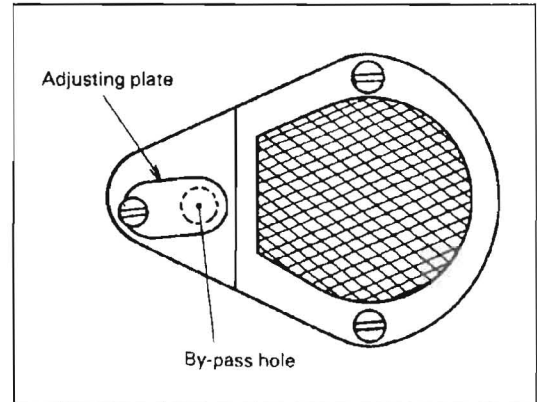

Fig.12

## 13、 Adjustment of oil pump (图 12):

The standard adjustment is as follows:

The adjusting plate keeps the bypass hole fully closed. To decrease splashing, open the bypass hole appropriately.

## 14、 Periodical cleaning (Fig.13, Fig.14, Fig.15):

Clean the feed dog, hook and oil pump periodically.

Maintenance of motor: Remove dust from the motor filter every one or two months.

Control box: Remove dust from the connector.

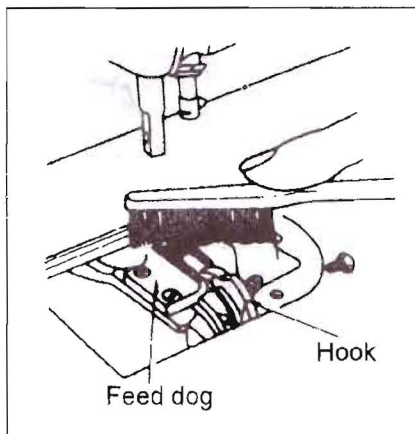

Fig.13

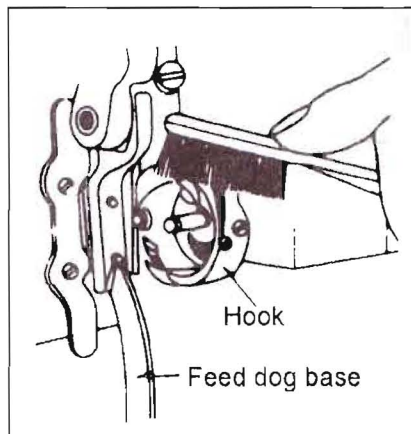

Fig.14

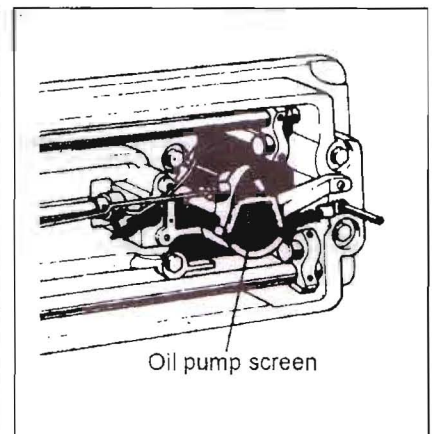
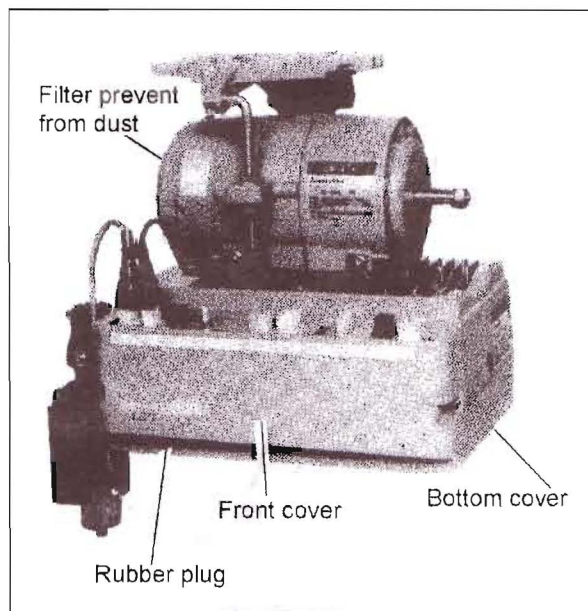

Fig.15

## 15、 Handling instructions (Motor and control box ) (Fig.16):

- 1) Keep your feet away from the pedal when turning the power on or off.
- 2) Always turn the power off when leaving your seat.
- 3) The brakes may fail if the power is switched off or power failure occurs during operation of the sewing machine.
- 4) The control box cover must be kept closed during machine operation to prevent malfunction caused by the entry of dirt.
- 5) The control circuitry must not be checked with a multimeter to protect the semiconductor parts from voltage.
- 6) The power switch must be turned off before tilting the machine head or touching the needle.
- 7) The three-phase motor must be grounded using ground wire (GREEN). The single-phase motor must not be wired to a starburst connection.



**Fig.16**

- 8) When manipulating the switch in the control box, first turn off the power switch, then open the front cover (Fig.16). If you have to open the bottom cover, wait for 10 minutes after the power switch has been turned off, since a high voltage is applied inside the box. (This is vital to discharge the built-in capacitors).
- 9) Use the motor away from high noise sources such as high-frequency welders.
- 10) A suitable capacity is 15A for a single-phase, and 10A for three-phase motor respectively.
- 11) The detector uses an optical detecting element. Do not allow dirt, dust, oil etc., to attach to the detecting plate when the machine pulley has been removed for adjustment. If dirty, gently wipe it off while avoiding scratching the plate. Also, care should be taken to avoid oil soaking into the crevices in the plate.

## 16、 Installation of belt cover:

Be sure to install the belt cover for safety.

## 17. How to wind the lower thread (Fig.17):

**Strength of winding:** Particularly in the case of nylon or polyester thread, wind the bobbin loosely.

**Uneven winding:** If the bobbin is wound unevenly, slide the thread guide toward the less wound portion of bobbin.

**Winding amount:** When the bobbin is wound excessively, loosen the adjusting screw. When the bobbin is wound insufficiently, tighten the adjusting screw.

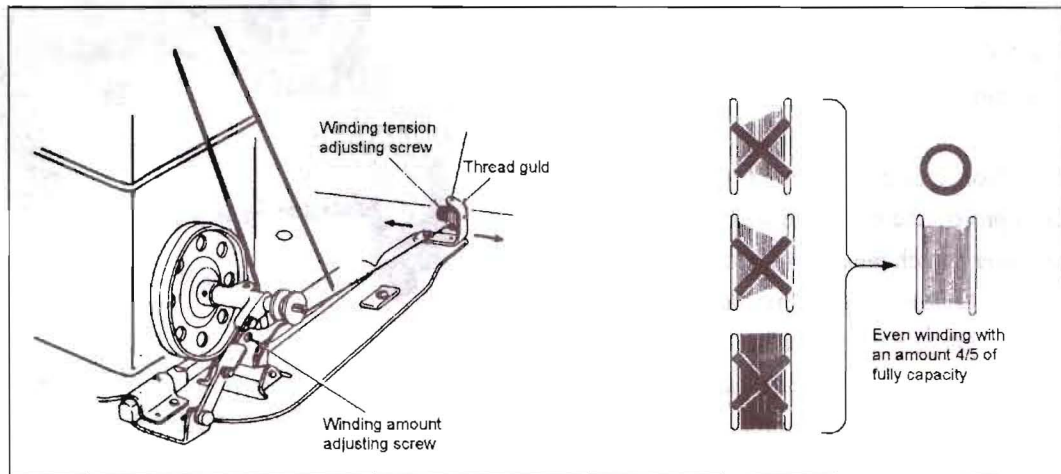

Fig.17

## 18. How to attach a needle (Fig.18):

**Note:** Before attach the needle, be sure to turn the power switch off.

**Note:** If thread snapping occurs during reverse sewing with polyester, it may be avoided by fitting the needle with the long groove shifted to the front side. Normally, avoid fitting the needle with the groove facing backward.

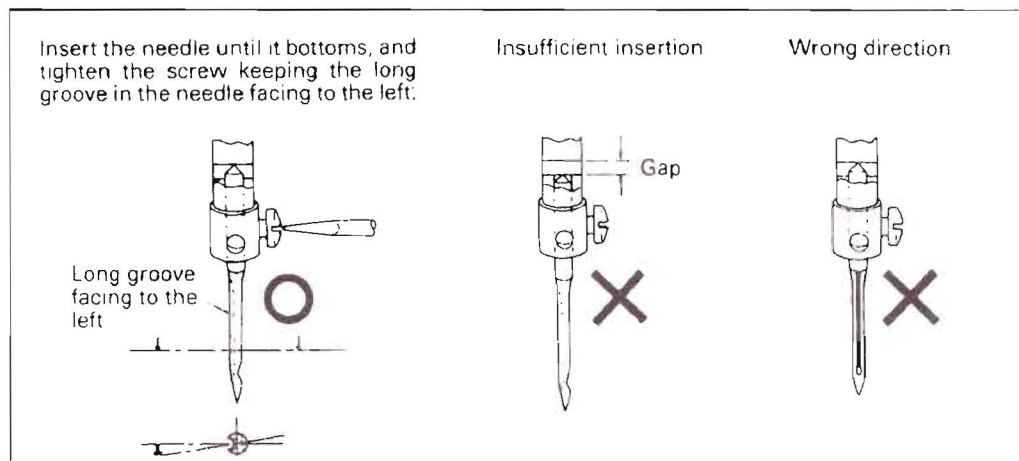

Fig.1

## 19、 How to route the upper thread (Fig.19):

Raise the thread take-up lever to its highest possible position, and route the upper thread in the order illustrated below.

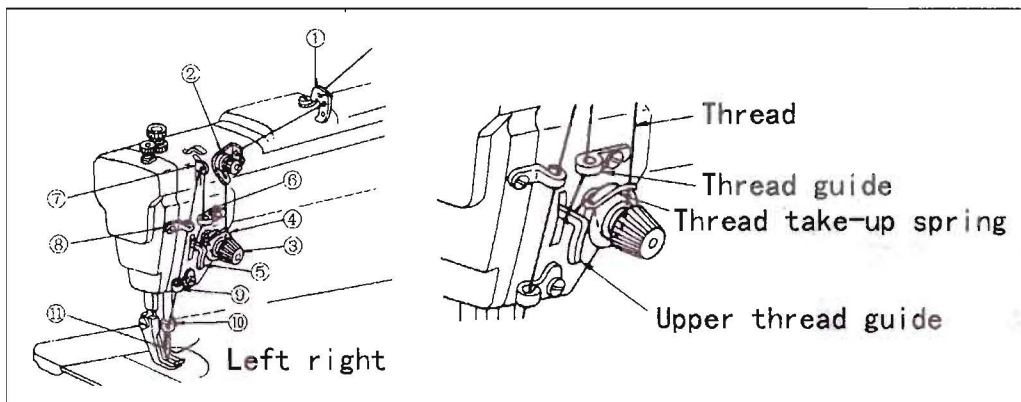

Fig.19

## 20、 Adjustment of stitch length and reverse sewing (Fig.20):

- 1) To change the stitch length, rotate the stitch length adjusting dial while pressing the “push” lever.
- 2) Pressing the stitch length adjusting lever for reverse stitching.

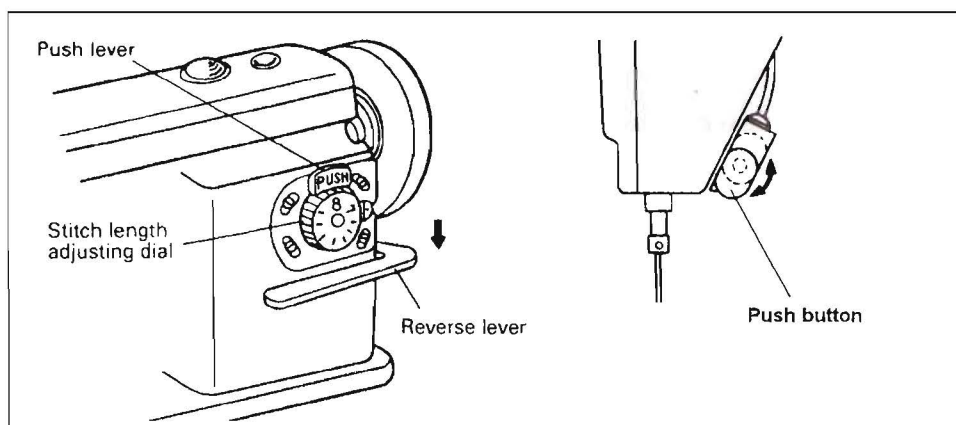

Fig.20

## 21、 Adjusting the thread tension (Fig.21):

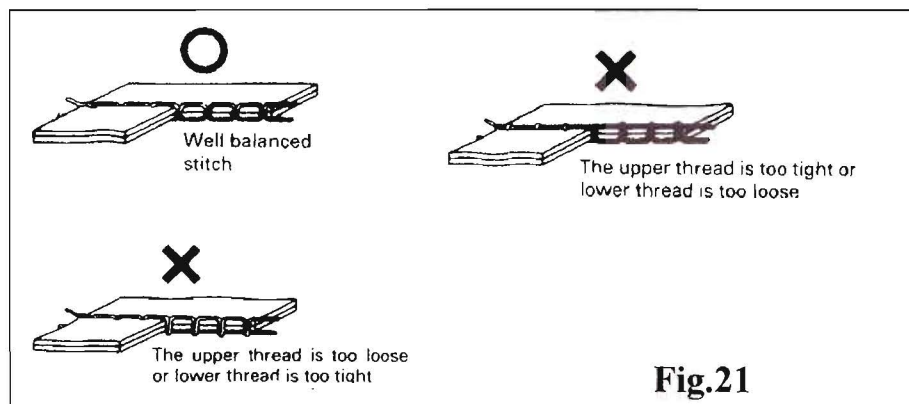

Fig.21

## 22、 Upper thread tension (Fig.22):

- 1) The upper thread can be adjusted based on the lower thread tension.
- 2) Adjustment can be done by rotating the thread tension nut.

For special fabric sewing with special thread, the desired tension can be obtained by adjusting the strength and operating range of thread take-up spring.

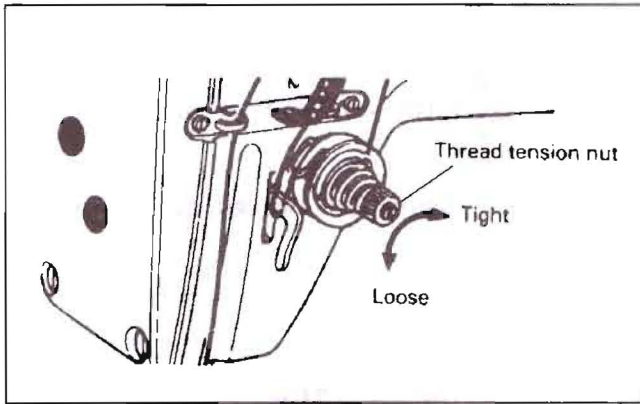

Fig.22

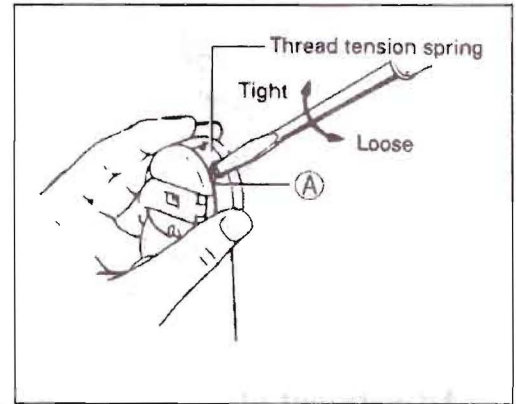

Fig.23

## 23、 Lower thread tension (Fig.23):

Lower thread tension can be adjusted by rotating screw "A".

## 24、 Adjustment of presser pressure (Fig.24):

- 1) Pressure should be adjusted according to the material to be sewn.
- 2) Pressure on both the walking foot and the presser foot can be adjusted.
- 3) Sewing pressure should be adjusted to the minimum required strength.

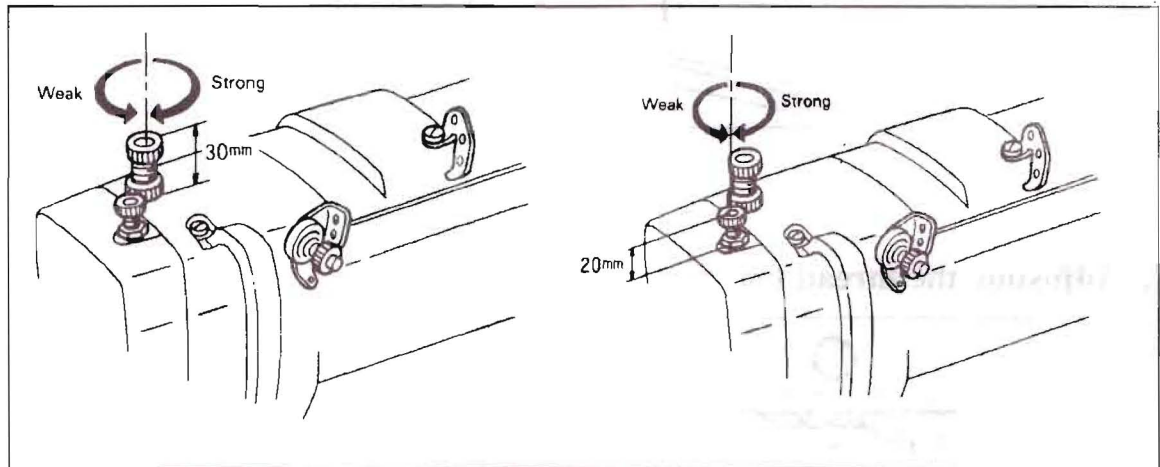

Fig.24

## 25、 Feed dog height (Fig.25):

- 1) Feed dog should be 1.0mm higher than the throat plate.
- 2) To adjust the dog height as follows:
  - (1) Loosen the screw "A", move the feed bar upward and downward.
  - (2) When adjustment is completed, tighten the screw "A".

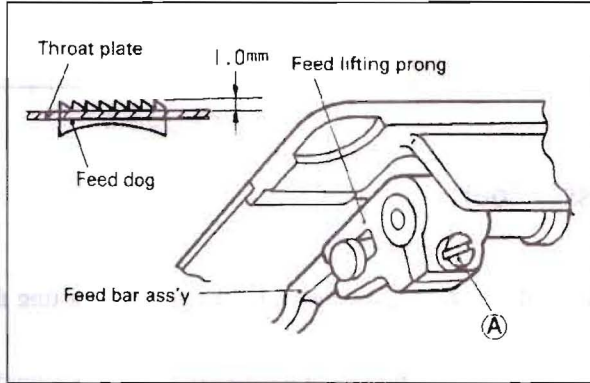

Fig.25

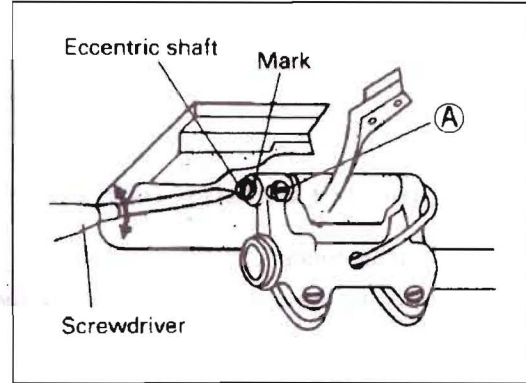

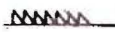

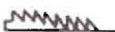

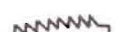

Fig.26

## 26、 Adjustment of feed dog inclination (Fig.26):

If necessary, adjust the inclination according to the material to be sewn as follows:

Position of mark on the eccentric shaft	Feed dog
 Horizontal	 Standard
 Up	 Front up (MAX.)
 Down	 Front down (MAX.)

- 1) Loosen the screw "A".
- 2) Rotate the eccentric shaft clockwise or counterclockwise with screw driver.
- 3) Tighten the screw "A".

## 27、 Adjustment of stitch length and forward/backward sewing (Fig.27):

- 1) Loosen the set screws located in the bracket.
- 2) Rotate the stitch length adjusting pin until the desired length is reached as follows:
  - (1) Clockwise: Increases the stitch length in forward sewing, and decreases the stitch length in backward sewing.
  - (2) Counterclockwise: Decreases the stitch length in forward sewing, and increases the stitch length in backward sewing.

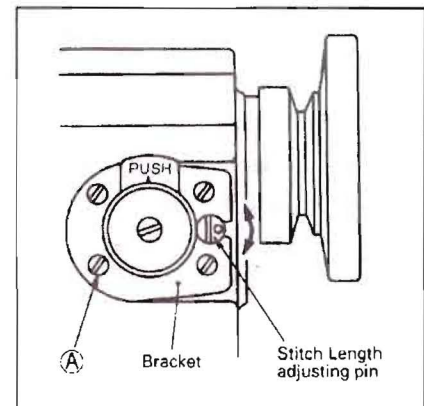

Fig.27

## 28、 Presser bar lifter (Fig.28):

Rotate the presser bar lifter in the direction of the arrow.  
This raises the presser foot.

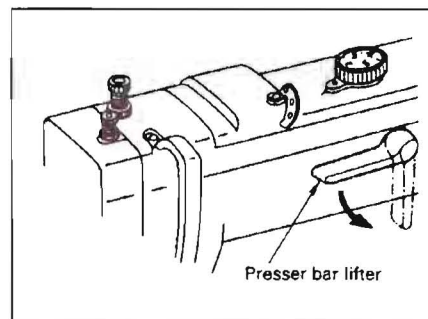

Fig.28

## 29、 Adjustment of walking foot and presser foot:

### 1) Adjustment of alternating movement (Fig.29):

(1) The alternating movement on the walking foot and presser foot can be adjusted by using adjusting dial located on the top cover.

(2) Face the desired number printed on the dial to the matching mark located on the top cover. The number printed on the dial represents the possible protrusion of the walking foot and presser foot from the throat plate when the alternating movements on these are evenly set.

(3) The alternating movements can be readjusted up to 2.0-5.0mm.

### 2) To change the balance of the alternating movements between the walking foot and presser foot (Fig.30):

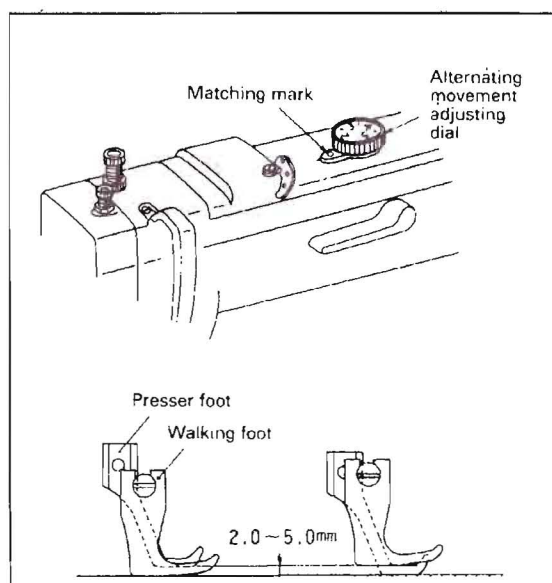

Fig.29

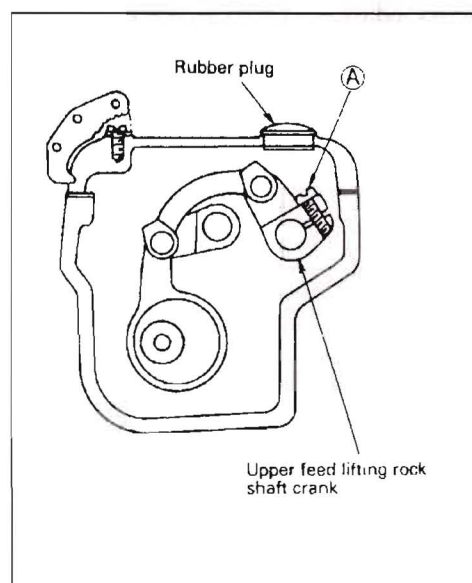

Fig.30

### (1) To increase the rise of the walking foot and decrease the rise of the presser foot:

- ① Remove the rubber plug of top cover.
- ② Rotate the pulley until the presser foot is slightly raised from the throat plate.
- ③ Loosen screw "A" (on the right side)
- ④ The built-in spring pulls down the presser foot until it makes contact with the throat plate. Tighten the screw "A".
- ⑤ After this adjustment, the protrusion of the presser foot has been decreased by a set distance. And the vertical motion of the walking foot has been increased by the same distance.

(2) As a contrary case (1) , to decrease the rise of the walking foot and increase the rise of presser foot as follows:

First, rotate the pulley until the walking foot is slightly raised from the throat plate. Next, loosen screw "A". Finally, tighten screw "A". This decreases the rise of the walking foot.

3) Installing the feed regulator bracket (Fig.31):

**Note: If the feed regulator bracket is poorly positioned, the resultant alternating movements may be too short or long, causing defective machine operation.**

(1) Set the clearance between special screw "A" located on the regulator stud and the side wall of the machine arm to 26.5mm as Fig.31.

(2) With the feed regulator stud held as explained is step (1) above, adjust the feed regulator bracket. This adjustment should insure a clearance of 12mm between the periphery of pin "B" located on the feed regulator bracket and the top cover mounting face located on the arm. Tighten screw "C".

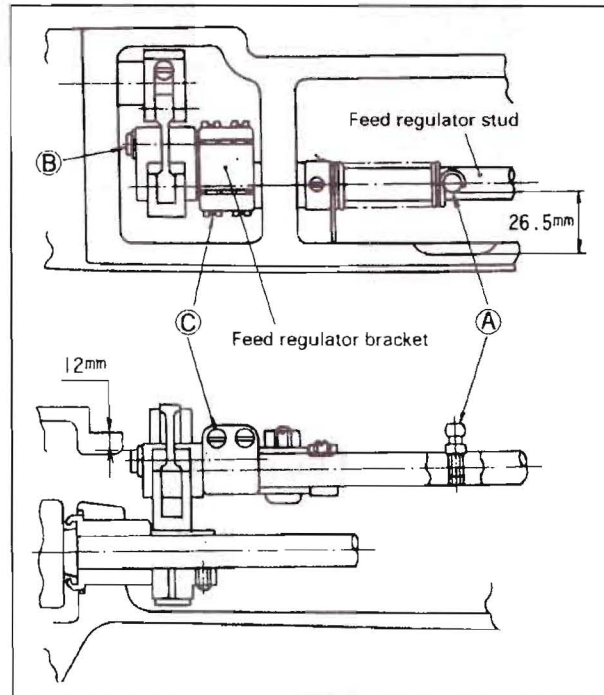

**Fig.31**

4) Feed pitch adjustment of walking foot (Fig.32):

The ratio of the upper feed amount (of the walking foot) to the lower feed amount (of the feed dog) has been adjusted to 1:1. However, the walking foot feeding amount can be increased or decreased depending on the operating conditions.

Loosen the nut located on the upper feed rock shaft crank (left), and shift to adjust the position of the pivot bracket upward or downward.

Upper position → Feed pitch → Small

Lower position → Feed pitch → Large

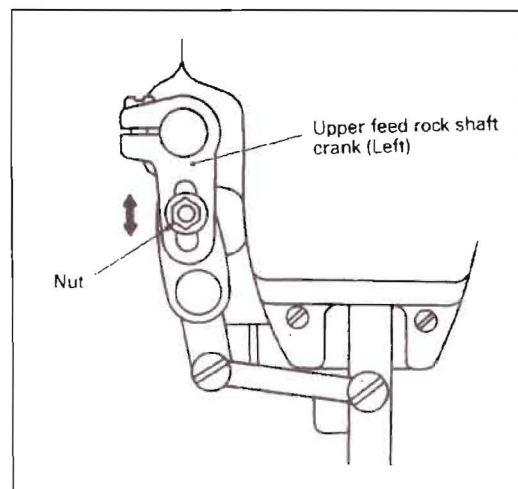

**Fig.32**



### 30、 Adjustment of feed timing (Fig.33):

- 1) The standard position of the eccentric feed cam and eccentric feed lifting cam are illustrated to Fig.33
- 2) Open the top cover, properly slide the eccentric ring to adjust the position.
- 3) eccentric feed cam can also be adjusted by removing the rubber plug located on the top cover. In the latter case, however, the built-in bevel gear is concealed; care should be taken when adjusting.

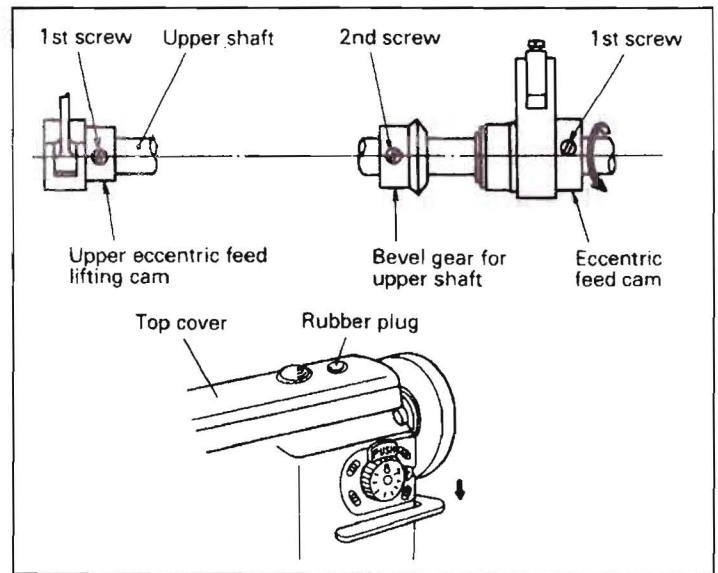

Fig.33

### 31、 Adjustment of thread trimmer mechanism:

- 1) The thread trimmer mechanism illustrated as Fig.34.

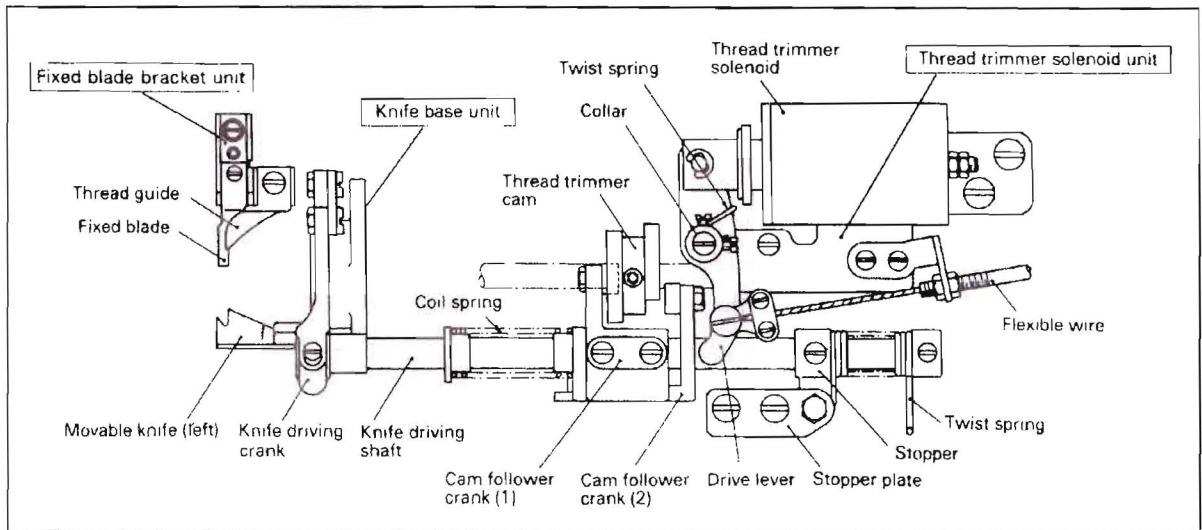
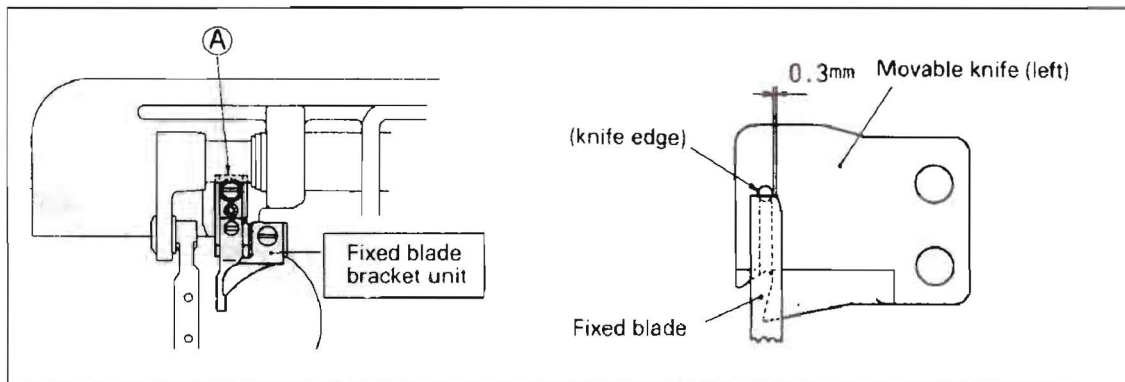

Fig.34

2) Relation between the fixed blade and movable knife (left) edge:

- (1) The standard position is illustrated as Fig.35.
- (2) The distance between the fixed blade and movable knife is 0.3mm.
- (3) The correct position of fixed blade bracket or fixed blade can be adjusted according to Fig.35.



**Fig.35**

3) Knife driving shaft:

- (1) The standard position is illustrated as Fig.36.
- (2) When assembling, the knife driving shaft must first be put through the drive arm.
- (3) Cam follower crank 1 must be positioned as illustrated to the right, and secured on the recess located on the knife driving shaft.
- (4) The stopper must be secured on the recess in such a way that the knife driving shaft is snug and smoothly rotates in the shaft direction.

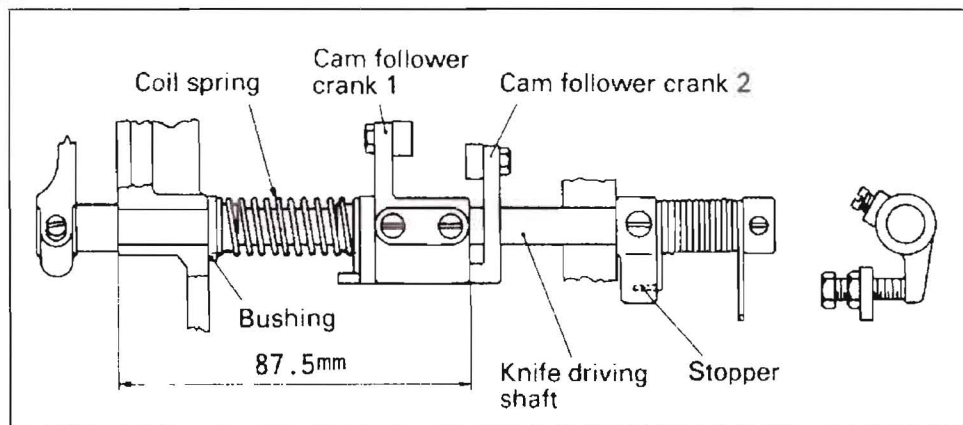
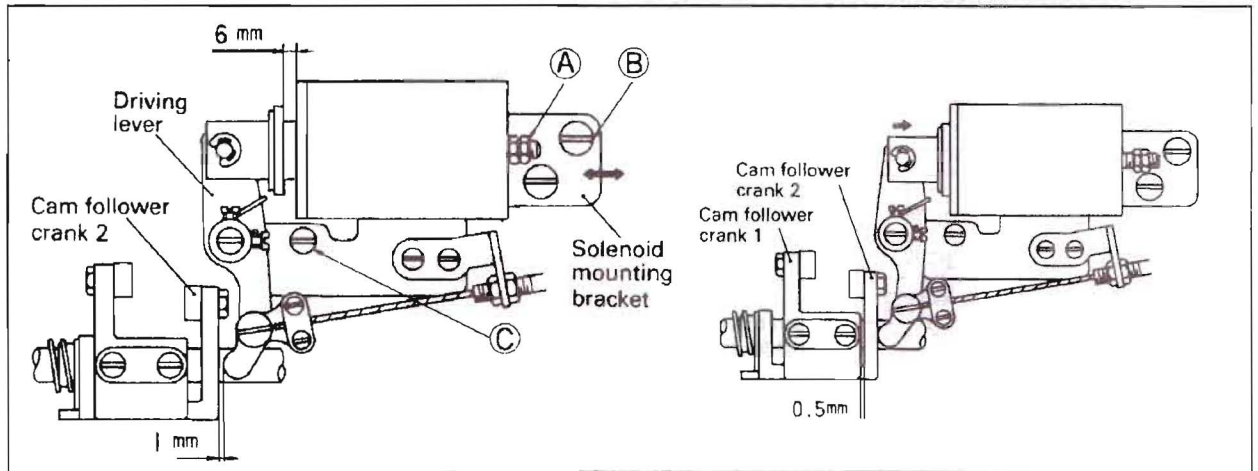

**Fig.36**

4) Installing the thread trimmer solenoid unit (Fig.37):

- (1) Operation stroke of the thread trimmer solenoid:
  - a. Standard operation stroke is 6.0mm.
  - b. This stroke can be adjusted by using nut "A".
- (2) Installing the unit:
  - a. The unit can be mounted by using screws "B" and "C".
  - b. Clearance of 1.0mm must be insured between the driving lever and cam follower crank 2 with stopper nut "A" made contact with solenoid.
  - c. In such a situation, activating the solenoid should create a clearance of 0.5mm between cam

follower crank 1 and 2. This situation is standard. To meet this standard, slide the solenoid mounting bracket in the direction of the arrow as illustrated, if adjustment is needed.

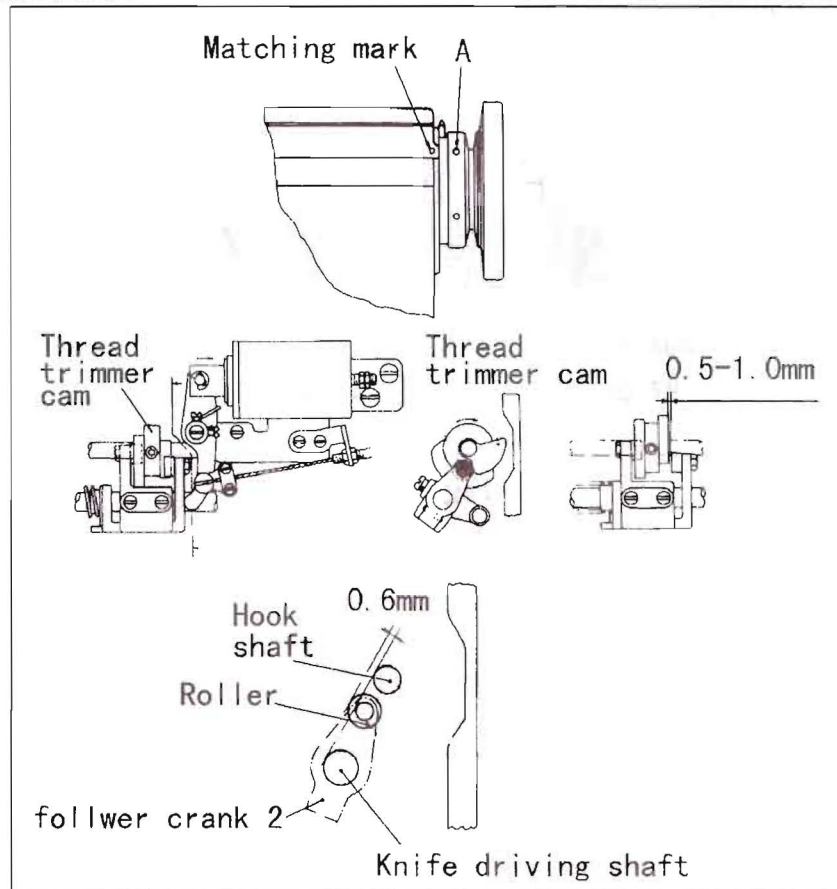

**Fig.37**

5) Installing the thread trimming cam (Fig.38):

- (1) Face the 2nd timing mark "A" (GREEN) located on the pulley to the matching mark on the arm.
- (2) With the thread trimmer solenoid activated, rotate the thread trimmer cam forward until the cam makes contact with the roller. Then, secure the cam.

(3) With the thread trimmer solenoid deactivated, allow the cam follower crank 2 to return to its original position. This should create a clearance of 0.5mm-1.0mm between the cam and roller end. This distance is standard.



**Fig.38**

6) Adjustment of knife engagement (Fig.39):

(1) Position of movable knife (left) and fixed blade:

See the Fig.39, the standard distances from the needle center are 7.5mm and 5mm from the movable knife (left) and fixed blade respectively:

(2) Adjustment of knife engagement:

With the solenoid activated, turn on the machine. This rotates the thread trimming cam which rotates the movable knife (left). When the movable knife (left) has moved to its farthest distance, the standard engagement of the blade is 1.5mm-2.0mm. The engagement can be adjusted by properly mounting the drive arm.

(3) Adjustment of knife engagement pressure:

a. If a thread is poorly cut, particularly when it is thick, slightly increase the engaging pressure. This should solve the problem.

b. The engaging pressure can be adjusted in this way: Loosen lock nut "B" and adjust it by using adjusting screw "A".

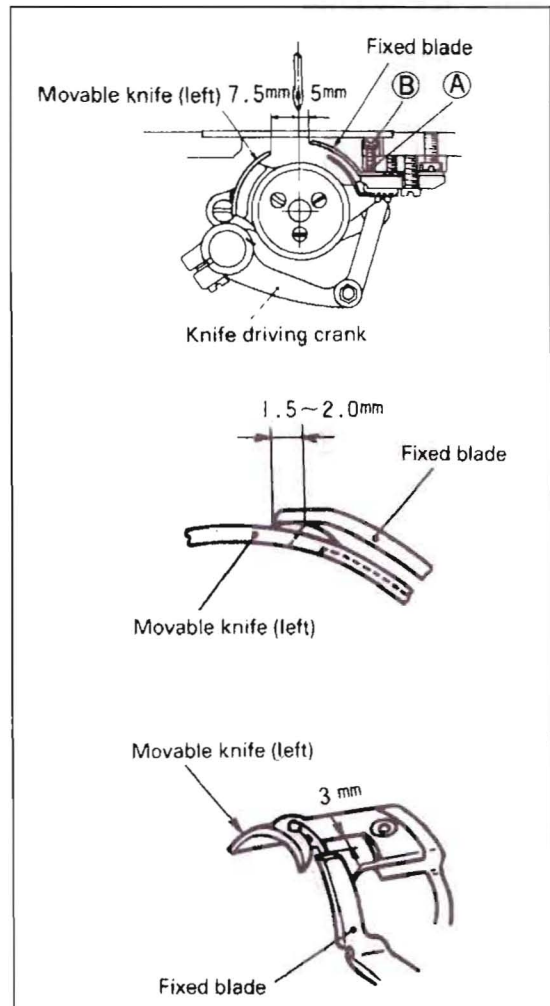

**Fig.39**

# A.ARM BED AND ITS ACCESSORIES

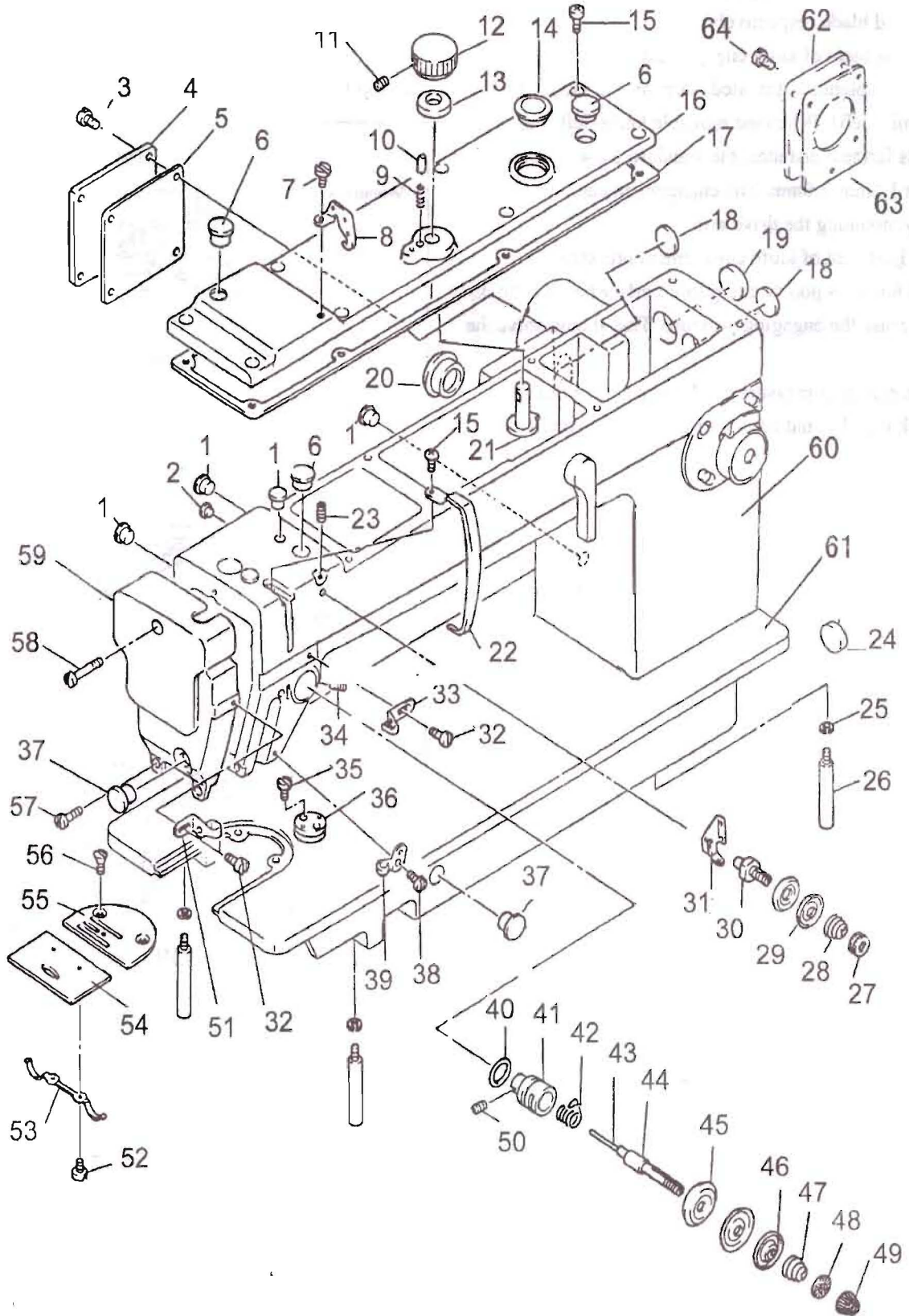

## A.ARM BED AND ITS ACCESSORIES

Fig. No.	Part No.	Description	GC0388-D	GC0388	Remarks
A01	HA300B2090	Rubber plug	4	4	φ 8.8
A02	HA300B2110	Rubber plug	1	1	φ 5.7
A03	HA300B2170	Screw	4	4	
A04	H6028B8001	Arm side cover	1	1	
A05	H6029B8001	Gasket for arm side cover	1	1	
A06	HA307B0673	Rubber plug	3	3	φ 11.8
A07	HA700F2100	Screw	1	1	SM11/64(40)×7
A08	H6017B8001	Thread guide	1	1	
A09	H6022B8001	Coil spring for upper feed lifting	1	1	
A10	H6023B8001	Stopper pin for upper feed lifting	1	1	
A11	H431040060	Set screw	2	2	GB/T80 M4×6
A12	H6025B8001	Dial for upper feed lifting	1	1	
A13	H6026B8001	Plate for upper feed lifting	1	1	
A14	HA309B0069	Oil check window	1	1	
A15	HA111G0683	Screw	8	8	SM11/64(40)×12
A16	H6015B8001	Top cover	1	1	
A17	H6016B8001	Gasket for top cover	1	1	
A18	H6030B8001	Rubber plug	2	2	
A19	H6031B8001	Rubber plug	1	1	
A20	H6032B8001	Rubber plug	1	1	
A21	H6020B8001	Upper feed lifting regulator cam	1	1	
A22	HA600C2020	Thread take-up cover	1	1	
A23	HA100B2110	Set screw	1	1	SM11/64(40)×5.5
A24	HA300B2100	Rubber plug	1	1	
A25	H005008060	Spring washer	3	3	GB/T93 6
A26	HA100B2220	Leg	3	3	
A27	HA710B0671	Pre-tension adjusting nut	1	1	SM11/64(40)
A28	HA710B0672	Thread tension spring	1	1	
A29	HA112B0693	Thread tension disc	2	2	
A30	HA710B0673	Thread tension stud	1	1	SM11/64(40)×31
A31	HA710B0674	Thread guide	1	1	
A32	HA106B0676	Screw	2	2	SM9/64(40)×6
A33	HA600B2050	Thread guide	1	1	
A34	HA300B2080	Set screw	1	1	SM15/64(28)×6.8
A35	HA300B2130	Screw	2	2	SM11/64(40)×5.5
A36	H2000B2040	Cloth guide plate	1	1	
A37	HA307B0674	Rubber plug	1	1	
A38	HA114I0674	Screw	1	1	SM9/64(40)×4.5
A39	HA500C2060	Thread guide	1	1	
A40	HA115B7011	O-ring	1	1	S15
A41	HA310B0703	Thread tension regulator bushing	1	1	
A42	HA806B0671	Thread take-up spring	1	1	
A43	H6037B8001	Thread releasing pin	1	1	

## A.ARM BED AND ITS ACCESSORIES

Fig. No.	Part No.	Description	GC0388-D	GC0388	Remarks
A44	HA806B0673	Thread tension stud	1	1	SM1/4(40)×49
A45	HA310B0705	Thread tension disc	2	2	
A46	HA310B0702	Thread tension releasing disc	1	1	
A47	H2206B0671	Thread tension spring	1	1	
A48	HA115B7010	Thumb nut revolution stopper	1	1	
A49	HA310B0701	Thumb nut	1	1	
A50	HA115B0708	Screw	1	1	SM9/64(40)×6
A51	HA607B0671	Thread guide	1	1	
A52	HA124B0713	Screw	2	2	SM3/32(56)×2.2
A53	HA124B0712	Plate spring for slide plate	1	1	
A54	H6812B8001	Slide plate	1	1	
A55	HA500B2030	Needle plate	1	1	
A56	H2000B2050	Screw	2	2	SM11/64(40)×8.85
A57	HA700B2030	Screw	2	2	SM11/64(40)×20
A58	H5341B8001	Screw	1	1	SM11/64(40)×26
A59	H6013B8001	Face plate	1	1	
A60	H6008B8001	Arm	1	1	
A61	H6010B8001	Bed	1	1	
A61	H6406B8001	Bed		1	
A62	H6409B8001	Arm bed cover		1	
A63	H6410B8001	Gasket for arm bed cover		1	
A64	HA300B2160	Screw		5	SM11/64(40)×12

# B.SEWING MECHANISM

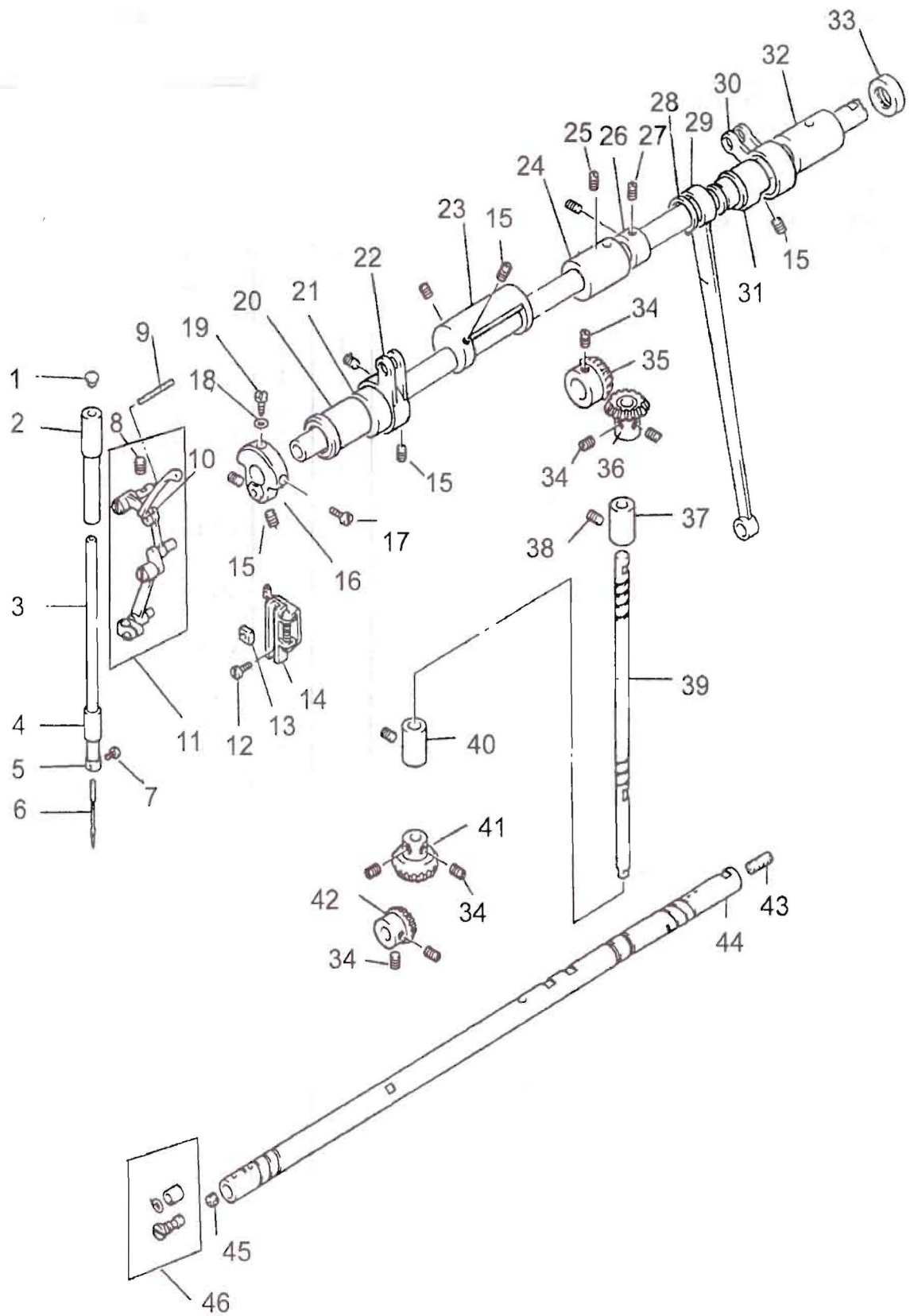



## B.SEWING MECHANISM

Fig. No.	Part No.	Description	GC0388-D	GC0388	Remarks
B01	HA300B2090	Rubber plug	1	1	
B02	H2009B0067	Needle bar bushing (upper)	1	1	
B03	H6005C8001	Needle bar	1	1	
B04	H6006C8001	Needle bar bushing (lower)	1	1	
B05	H2000G2020	Thread guide	1	1	
B06	H2000G2030	Needle	1	1	DP×17 #22
B07	HA100C2170	Set screw	1	1	SM1/8(44)×4.5
B08	HA100C2020	Screw	1	1	SM15/64(28)×10
B09	HA700H2040	Felt	1	1	
B10	HA804H0651	Oil shade cap	1	1	
B11	H6007C7101	Thread take-up lever assy	1	1	
B12	HA300C2030	Screw	2	2	SM11/64(40)×8
B13	HA100C2200	Slide block	1	1	
B14	H2205C0661	Needle bar connecting link guide	1	1	
B15	HA307C0662	Set screw	2	2	SM1/4(40)×6
B16	H6023C8001	Needle bar crank	1	1	
B17	HA100C2060	Screw	1	1	SM9/32(28)×13
B18	HA705C0662	O-ring	1	1	
B19	HA100C2070	Set screw	1	1	SM9/32(28)×14
B20	H6011C8001	Upper shaft bushing (upper)	1	1	
B21	H6013C8001	Upper feed lifting cam	1	1	
B22	H6016C8001	Upper feed rock crank (left)	1	1	
B23	H6015C8001	Balance weight	1	1	
B24	HA100D2040	Upper shaft bushing (middle)	1	1	
B25	HA3411D308	Screw	1	1	SM15/64(28)×7
B26	HA108G0661	Collar for upper shaft	1	1	
B27	HA105D0662	Screw	2	2	SM1/4(40)×4
B28	HA112D3012	C-type retaining ring	1	1	20
B29	H6020C8001	Crank rock	1	1	
B30	H6019C8001	Upper feed rock crank (right)	1	1	
B31	H6018C8001	Upper feed lifting cam (right)	1	1	
B32	H6021C8001	Upper shaft bushing (right)	1	1	
B33	HA306D0066	Oil seal	1	1	
B34	HA108C0663	Screw	8	8	SM1/4(40)×7
B35	HA113D2112	Upper shaft gear	1	1	
B36	HA113D2122	Vertical shaft gear (upper)	1	1	
B37	HA100D2110	Vertical shaft bushing (upper)	1	1	
B38	HA100C2020	Screw	2	2	SM15/64(28)×10
B39	H6022C8001	Vertical shaft	1	1	
B40	HA600D2010	Vertical shaft bushing (lower)	1	1	
B41	HA113D2222	Vertical shaft gear (lower)	1	1	
B42	HA113D2212	Lower shaft gear	1	1	
B43	HA104D0652	Rubber plug	1	1	

## B.SEWING MECHANISM

Fig. No.	Part No.	Description	GC0388-D	GC0388	Remarks
B44	H6010C8001	Upper shaft	1	1	
B45	HA704C0653	Felt	1	1	
B46	HA7121C104	Oil amount adjusting pin assay	1	1	

# C.FEEDING AND FEED LIFTING & LOWER SHAFT MECHANISM

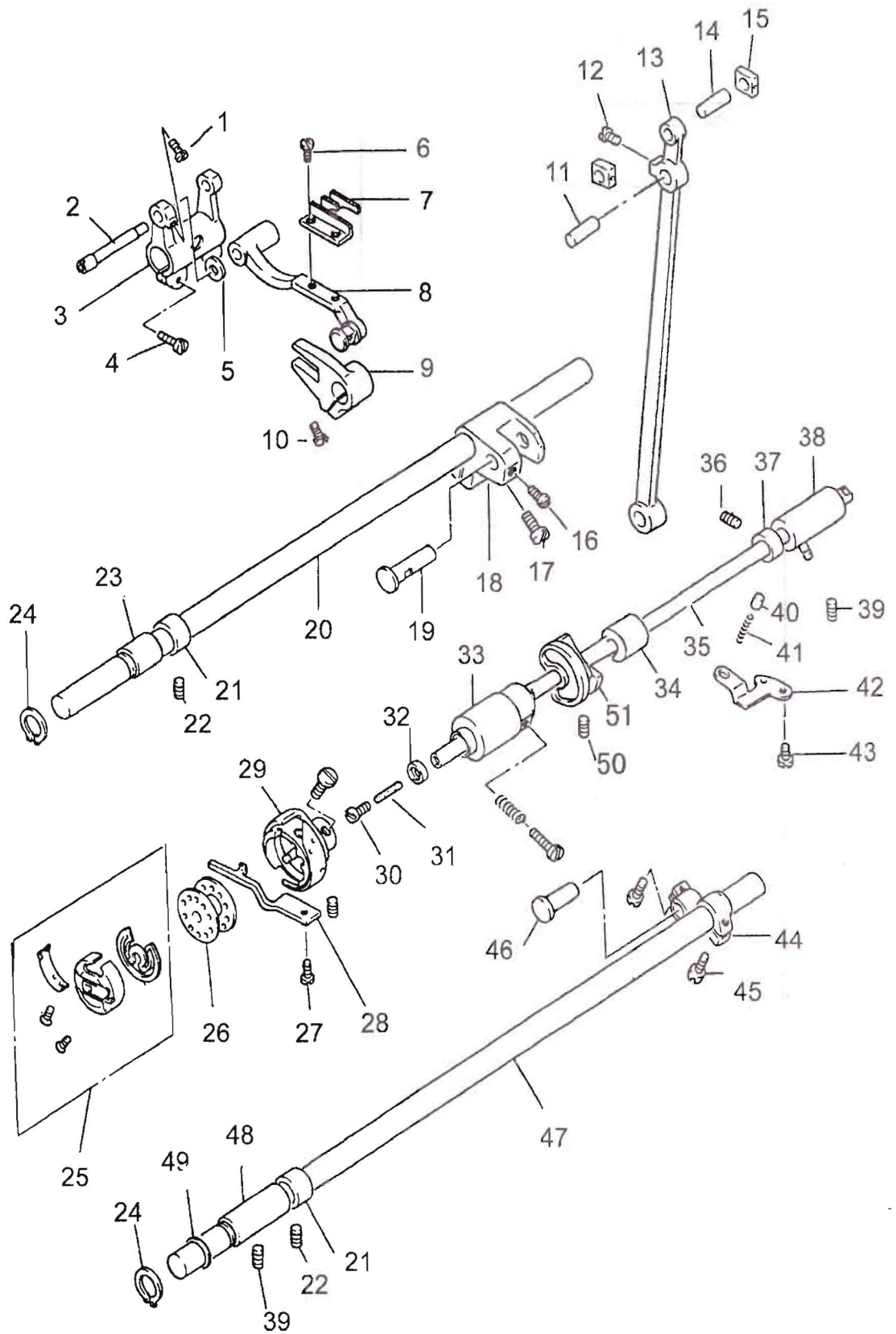

## C.SEWING MECHANISM & FEED ROCK LOWER SHAFT

Fig. No.	Part No.	Description	GC0388-D	GC0388	Remarks
C01	HA300C2030	Screw	1	1	SM11/64(40)×8
C02	HA705J0654	Shaft for feed bar (eccentric)	1	1	
C03	HA104G0011	Feed rock shaft crank	1	1	
C04	HA104G0012	Screw	2	2	SM3/16(28)×12
C05	HA104G0656	Washer	1	1	
C06	HA104G0654	Screw	2	2	SM1/8(44)×6
C07	H6005D8001	Feed dog	1	1	
C08	HA705J0021	Feed bar assay	1	1	
C09	H1204D0651	Feed lifting rock shaft fork	1	1	
C10	HA111G0683	Screw	1	1	SM11/64(40)×12
C11	H6010D8001	Upper feed rock shaft	1	1	
C12	HA300C2030	Screw	1	1	SM11/64(40)×8
C13	H6011D8001	Connecting rod for upper feed	1	1	
C14	H6012D8001	Upper feed rock shaft	1	1	
C15	H4722G8001	Square block	2	2	
C16	HA113F0684	Screw	1	1	SM15/64(28)×8.5
C17	HA800F2020	Screw	1	1	SM15/64(28)×13.5
C18	H6008D8001	Feed rock shaft crank (right)	1	1	
C19	H6009D8001	Pin	1	1	
C20	H6006D8001	Feed rock shaft	1	1	
C21	HA105D0661	Collar for feed rock shaft	2	2	
C22	HA105D0662	Screw	4	4	SM1/4(40)×4
C23	HA100G2040	Bushing for feed rock shaft	1	1	
C24	H007009150	C-type retaining ring	1	1	GB/T894.1 15
C25	HA900E2030	Bobbin case	1		
C25	HA600E2080	Bobbin case		1	
C26	HA600E2060	Bobbin	1	1	
C27	HA100E2150	Screw	1	1	SM11/64(40)×10
C28	H2100E2010	Hook positioner	1	1	
C29	H2200C2050	Rotating hook	1		
C29	HA606E0066	Rotating hook		1	
C30	HA1111E104	Screw	1	1	SM3/16(32)×9.7
C31	HA1111E204	Oil felt for hook shaft	1	1	
C32	HA700E2030	Oil seal	1		
C32	HA106E0071	Oil seal		1	
C33	HA704B0654	Bushing for hook shaft (left)	1		
C33	H6404D8001	Bushing for hook shaft (left)		1	
C34	HA704B0653	Bushing for hook shaft (middle)	1	1	
C35	H6015D8001	Hook shaft	1	1	
C36	HA305E0662	Screw	2	2	SM15/64(28)×4.5
C37	HA305E0661	Collar for hook shaft	1	1	
C38	HA311E0671	Bushing for hook shaft (right)	1	1	
C39	HA100C2020	Screw	1	1	SM15/64(28)×10

## C.SEWING MECHANISM & FEED ROCK LOWER SHAFT

Fig. No.	Part No.	Description	GC0388-D	GC0388	Remarks
C40	HA300E2100	Plunger	1	1	
C41	HA300E2110	Coil spring	1	1	
C42	HA300E2040	Guide plate	1	1	
C43	HA104F0654	Screw	1	1	SM15/64(28)×10
C44	HA705K0661	Feed lifting rock shaft crank (right)	1	1	
C45	HA104G0012	Screw	2	2	SM3/16(28)×12
C46	HA100G2070	Pin	1	1	
C47	H6013D8001	Feed lifting rock shaft	1	1	
C48	HA100G2120	Bushing for feed lifting shaft	1	1	
C49	HA100G2130	Washer	1	1	
C50	HA710E0692	Screw	2		SM1/4(40)×10
C51	HA710E0691	Thread trimmer cam	1		

# D.STITCH REGULATOR MECHANISM

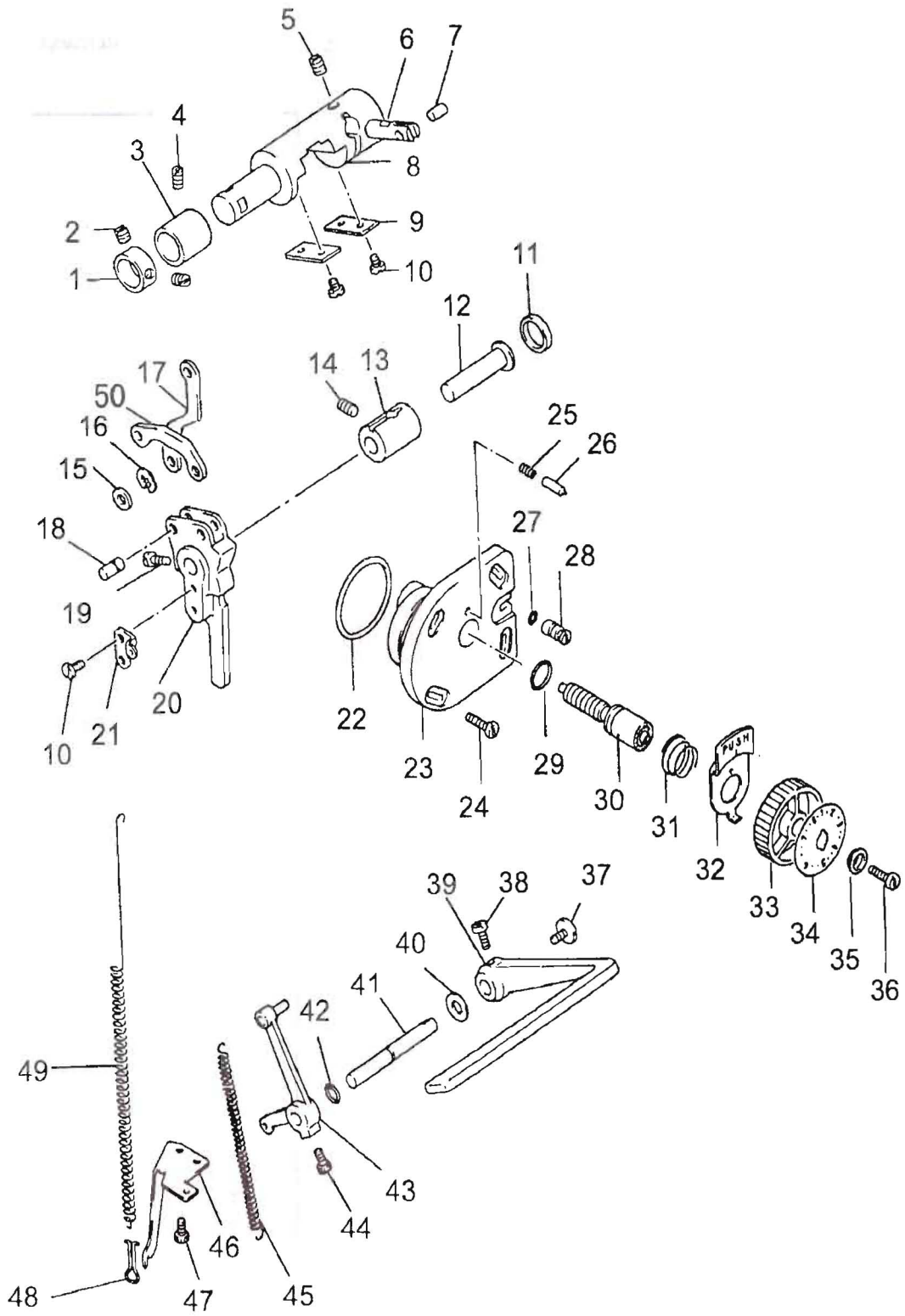

## D.STITCH LENGTH MECHANISM

Fig. No.	Part No.	Description	GC0388-D	GC0388	Remarks
D01	HA108G0661	Collar for reverse bar	1	1	
D02	HA105D0662	Screw	2	2	SM1/4(40)×4
D03	HA100G2040	Bushing for reverse bar	1	1	
D04	HA100B2110	Screw	1	1	SM11/64(40)×5.5
D05	HA100C2020	Screw	1	1	SM15/64(28)×10
D06	H6007E8001	Bracket pin	1	1	
D07	H6008E8001	Pin	1	1	
D08	H6006E8001	Reverse bar	1	1	
D09	H4723G8001	Guide plate	2	2	
D10	HA300C2030	Screw	6	6	SM11/64(28)×8
D11	HA700B2120	Rubber plug	1	1	
D12	HA100F2040	Pin	1	1	
D13	HA704B0655	Bushing for feed regulator	1	1	
D14	HA3411D308	Screw	1	1	SM15/64(28)×7
D15	H6012E8001	Washer	2	2	
D16	H007013040	E-type ring	2	2	GB/T896 4
D17	H6010E8001	Link	1	1	
D18	H6013E8001	Pin	2	2	
D19	HA113F0684	Screw	1	1	SM15/64(28)×8.5
D20	H6009E8001	Feed regulator	1	1	
D21	H6018E8001	Spring retainer	1	1	
D22	HC01360	O-ring	1	1	GB3452.1 36
D23	H6015E8001	Bracket	1	1	
D24	HA100E2150	Screw	4	4	SM11/64(40)×10
D25	HA100F2090	Spring for stopper pin	1	1	
D26	HA700F2030	Stopper pin	1	1	
D27	HA113F3022	O-ring	1	1	
D28	H6017E8001	Feed regulator pin	1	1	
D29	HA109F0674	O-ring	1	1	
D30	HA720F0681	Screw bar	1	1	
D31	HA720F0687	Coil spring	1	1	
D32	HA720F0683	Stopper pin releasing lever	1	1	
D33	HA7421F120	Dial	1	1	
D34	H2205D0661	Plate for stitch length	1	1	
D35	HA720F0685	Bushing	1	1	
D36	HA720F0686	Screw	1	1	SM3/16(28)×18
D37	HA113F0683	Screw	1	1	SM3/16(28)×6.5
D38	HA104F0654	Screw	2	2	SM15/64(28)×10
D39	HA309F0671	Feed reversing lever	1	1	
D40	HA100F2110	Spring washer	1	1	
D41	H3008F0671	Feed reversing lever shaft	1	1	
D42	HA113F3022	O-ring	1	1	
D43	H6020E7101	Crank for feed reversing lever	1	1	

## D.STITCH LENGTH MECHANISM

Fig. No.	Part No.	Description	GC0388-D	GC0388	Remarks
D44	HA100F2130	Screw	1	1	SM15/64(28)×14.5
D45	H6023E8001	Spring	1	1	
D46	HA800F2010	Spring holder	1	1	
D47	HA800F2020	Screw	1	1	SM15/64(28)×13.5
D48	HA806C0675	Spring holder	1	1	
D49	HA806C0674	Coil spring	1	1	
D50	H6011E8001	Link for reserve feed	1		



# E.UPPER FEED ROCK SHAFT MECHANISM

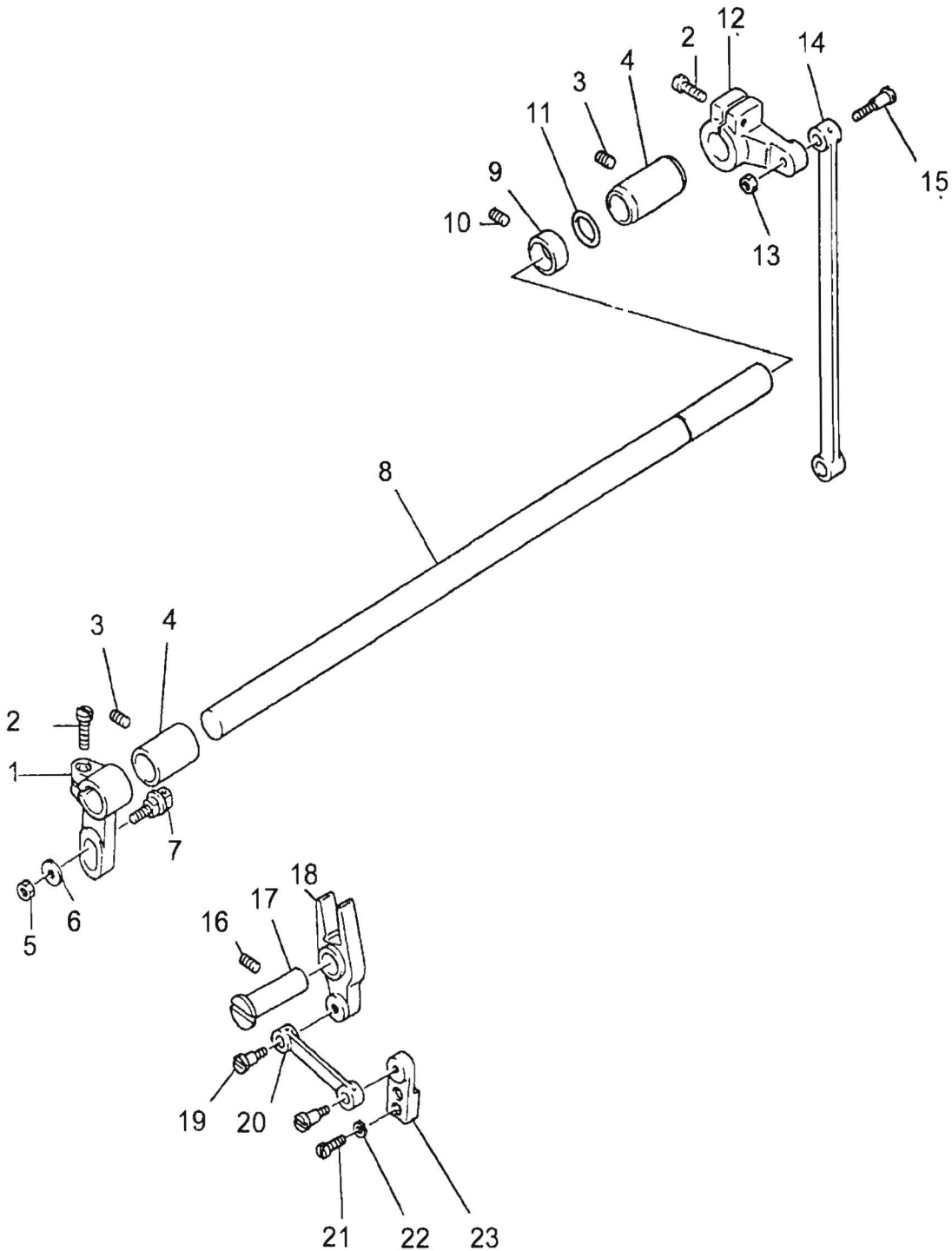

## E.TOP FEED MECHANISM

Fig. No.	Part No.	Description	M	H	Remarks
E01	H6006F8001	Upper feed rock shaft crank (left)	1	1	
E02	H6017F8001	Screw	2	2	SM15/64(28)×18
E03	HA100B2110	Screw	2	2	SM11/64(40)×5.5
E04	H6008F8001	Bushing for upper feed rock shaft crank	2	2	
E05	H2013N0067	Nut	1	1	SM1/4×24
E06	H2013J0065	Washer	1	1	6
E07	H2121I0065	Feed connecting slick block	1	1	
E08	H6007F8001	Upper feed rock shaft	1	1	
E09	HA108G0661	Collar	1	1	
E10	HA105D0662	Screw	2	2	SM1/4(40)×4
E11	H6018F8001	O-ring	1	1	
E12	H6013F8001	Upper feed rock shaft crank (right)	1	1	
E13	H2010J0066	Nut	1	1	SM9/32×28
E14	H6014F8001	Feed driver connecting rod	1	1	
E15	H2012N0066	Screw	1	1	SM9/32(28)×7
E16	HA3411D308	Screw	1	1	SM15/64(28)×7
E17	H6010F8001	Hinge pin	1	1	
E18	H6015F8001	Feed connecting lever	1	1	
E19	H2004J0662	Screw	2	2	SM1/4(40)×5
E20	H6016F8001	Walking foot connecting rod	1	1	
E21	H2004J0067	Screw	2	2	SM9/64(40)×7
E22	HA100L2050	Spring washer	2	2	3.5
E23	H2004J0661	Feed arm	1	1	

# F. UPPER FEED LIFTING ROCK SHAFT MECHANISM

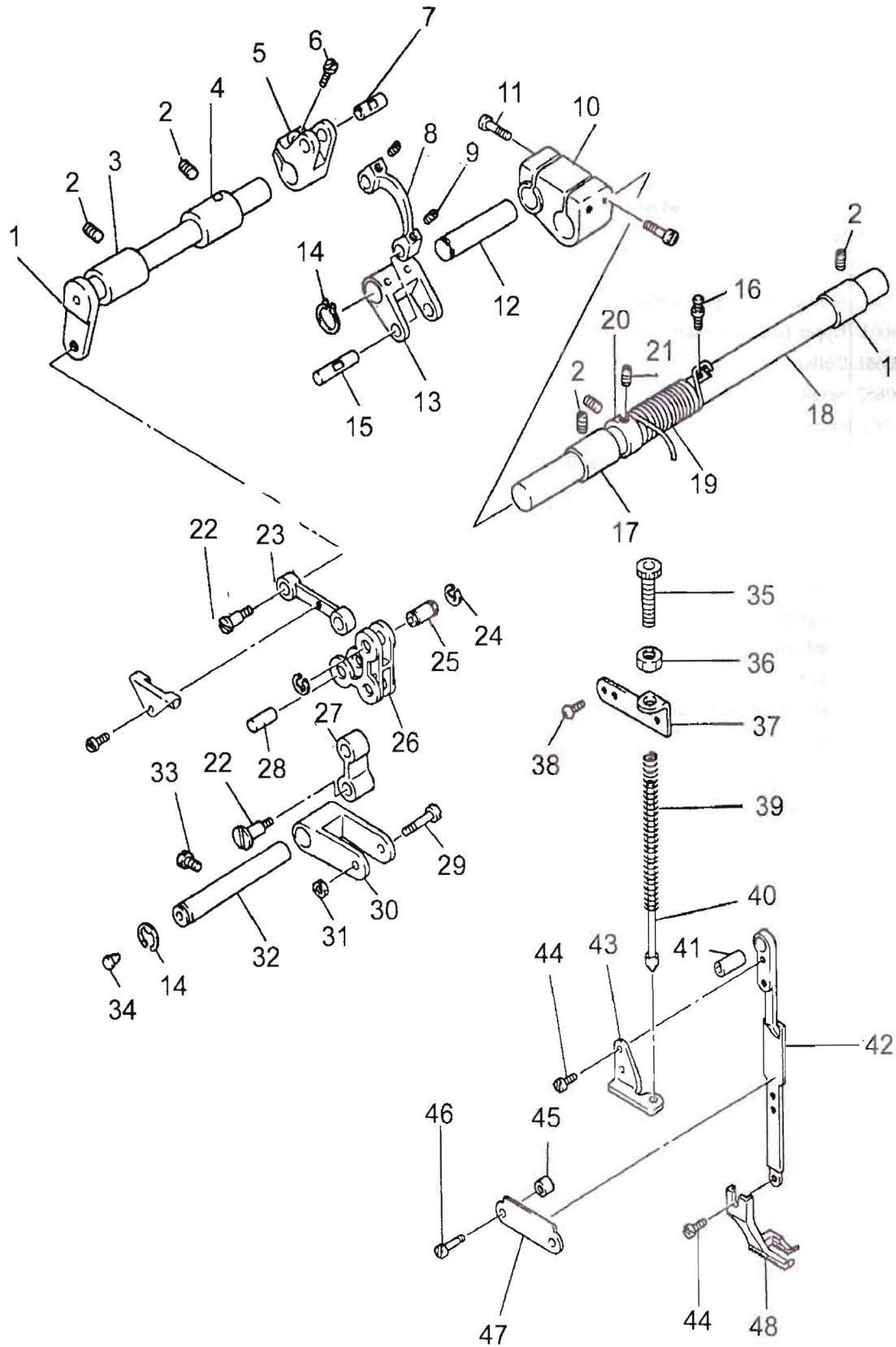

## F. UPPER FEED LIFTING ROCK SHAFT MECHANISM

Fig. No.	Part No.	Description	GC0388-D	GC0388	Remarks
F01	H6005G8001	Upper feed lifting rock shaft	1	1	
F02	HA100B2110	Screw	4	4	SM11/64(40)×5.5
F03	H6006G8001	Bushing for upper feed lifting rock shaft (left)	1	1	
F04	H6007G8001	Bushing for upper feed lifting rock shaft (right)	1	1	
F05	H6009G8001	Upper feed lifting rock crank	1	1	
F06	HA800F2020	Screw	1	1	SM15/64(28)×13.5
F07	H6010G8001	Upper feed lifting rock crank shaft	1	1	
F08	H6011G8001	Link	1	1	
F09	H6039G8001	Screw	2	2	SM11/64(40)×3.8
F10	H6013G8001	Upper feed regulator bracket	1	1	
F11	HA7311C606	Screw	4	4	SM11/64(40)×15
F12	H6014G8001	Shaft for upper feed lifting rock shaft	1	1	
F13	H6015G8001	Crank for upper feed lifting rock crank	1	1	
F14	H007009100	C-type ring	1	1	GB/T894.1 10
F15	H6016G8001	Pin	1	1	
F16	H6020G8001	Cam follower	1	1	SM15/64(28)×10
F17	HA100G2040	Bushing for upper feed shaft	2	2	
F18	H6019G8001	Upper feed regulator shaft	1	1	
F19	H6021G8001	Spring	1	1	
F20	HA108G0661	Collar	1	1	
F21	HA105D0662	Screw	2	2	SM1/4(40)×4
F22	H2004J0662	Screw	2	2	SM1/4(40)×5
F23	H6023G8001	Link for feed lifting rock shaft	1	1	
F24	H007013060	E-type ring	2	2	GB/T896 6
F25	H6022G8001	Pin	1	1	
F26	H6024G8001	Bell crank	1	1	
F27	H6027G8001	Link	1	1	
F28	H6028G8001	Pin	1	1	
F29	H6029G8001	Stud screw	1	1	SM15/64(28)×5
F30	H6030G8001	Bell crank support	1	1	
F31	H6040G8001	Nut	1	1	SM15/64(28)
F32	H6031G8001	Bell crank support shaft	1	1	
F33	HA110D0672	Screw	1	1	SM15/64(28)×12
F34	HA300B2110	Rubber plug	1	1	
F35	H2010J0065	Thumb screw	1	1	SM9/32(28)×35
F36	H2010J0066	Nut	1	1	SM9/32(28)
F37	H6032G8001	Presser regulating bracket	1	1	
F38	HA300C2030	Screw	2	2	SM11/64(40)×8
F39	H6038G8001	Spring	1	1	
F40	H6034G7101	Spring guide bar assy	1	1	
F41	H6037G8001	Bushing for walking foot guide link	1	1	
F42	H6036G8001	Walking foot guide link	1	1	
F43	H6033G8001	Spring guide bar holder	1	1	

## F.UPPER FEED LIFTING ROCK SHAFT MECHANISM

Fig. No.	Part No.	Description	GC0388-D	GC0388	Remarks
F44	H2000I2050	Screw	3	3	SM9/64(40)×8  SM11/64(40)×12
F45	H2000N0040	Washer	2	2	
F46	HA111G0683	Screw	2	2	
F47	H2000N0030	Walking foot guide bracket	1	1	
F48	H2000N0010	Walking foot	1	1	

# G.PRESSER FOOT MECHANISM

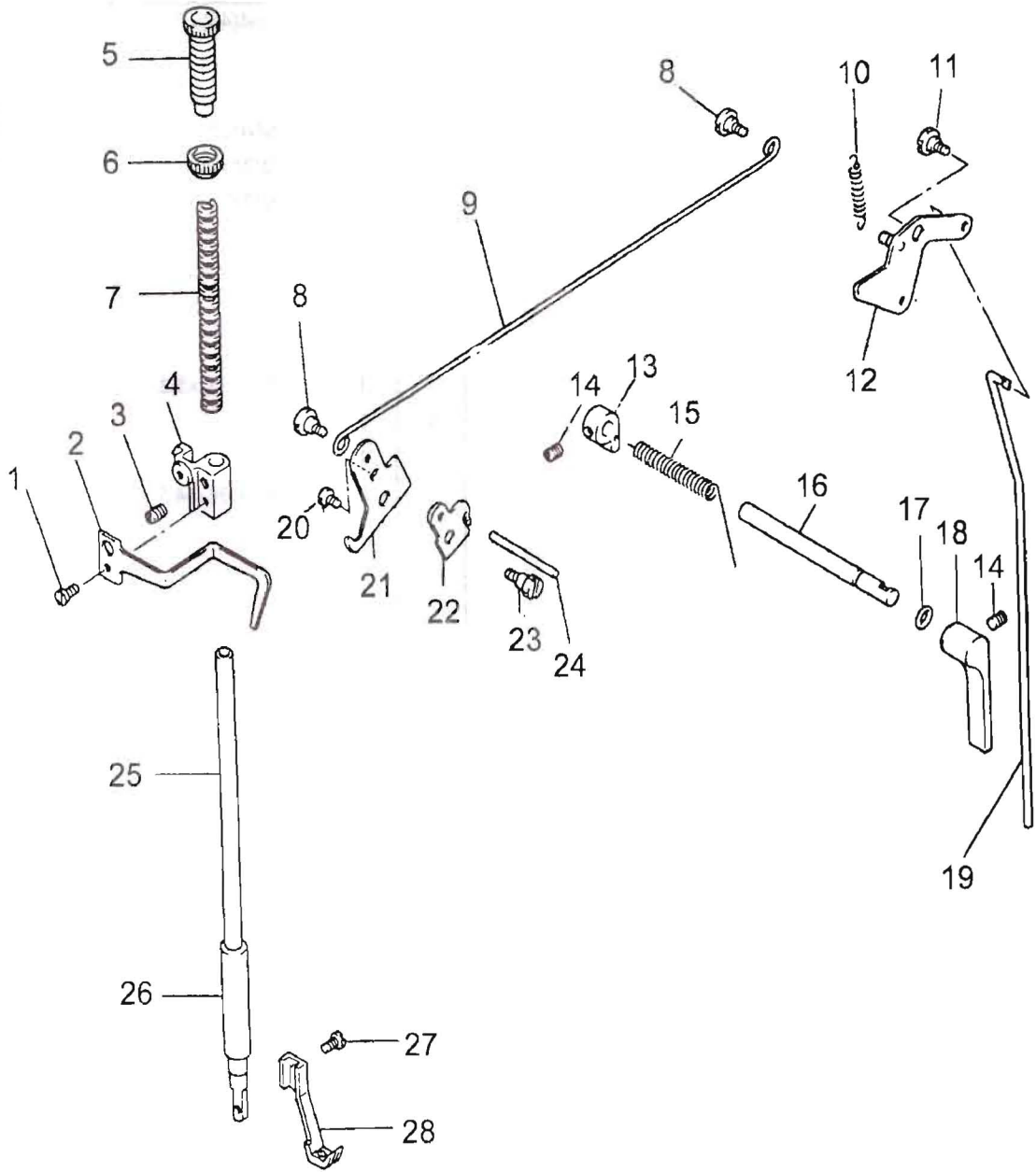

# G.PRESSER FOOT MECHANISM

Fig. No.	Part No.	Description	GC0388-D	GC0388	Remarks
G01	HA700F2100	Screw	1	1	SM11/64(40)×7
G02	H6023H8001	Thread guide	1	1	
G03	H6027H8001	Presser bar guide bracket	1	1	
G04	HA3411D308	Screw	1	1	SM15/64(28)×7
G05	H6022H8001	Thumb screw	1	1	SM1/2(28)×43
G06	HA117H0692	Nut	1	1	SM1/2(28)
G07	H6020H8001	Presser bar spring	1	1	
G08	HA107H0662	Screw	2	2	SM3/16(28)×3.5
G09	H6013H8001	Knee lifter rod	1	1	
G10	H6017H8001	Spring	1	1	
G11	HA100H2050	Stud bolt	1	1	SM15/64(28)×5.2
G12	H6016H8001	Knee lifter lever	1	1	
G13	H6009H7101	Presser bar lifting cam	1	1	
G14	HA305E0662	Screw	2	2	SM15/64(28)×4.5
G15	H6008H8001	Spring	1	1	
G16	H6007H8001	Presser bar lifting shaft	1	1	
G17	HA300H2080	O-ring	1	1	
G18	H6006H8001	Presser bar lifter	1	1	
G19	H6018H8001	Knee lifter connecting rod	1	1	
G20	HA107H1013	Screw	1	1	SM11/64(40)×6.5
G21	H6014H8001	Knee lifter lever (left)	1	1	
G22	HA305H6611	Tension releasing cam	1	1	
G23	HA100H2050	Stud bolt	1	1	SM15/64(28)×5.7
G24	H6037B8001	Thread releasing pin	1	1	
G25	H6019H8001	Presser bar	1	1	
G26	HA704B0651	Bushing for presser bar	1	1	
G27	HA7311CH06	Screw	1	1	SM9/64(40)×8
G28	H2205F0651	Presser foot	1	1	

# H.UPPER FEED ROCK SHAFT MECHANISM

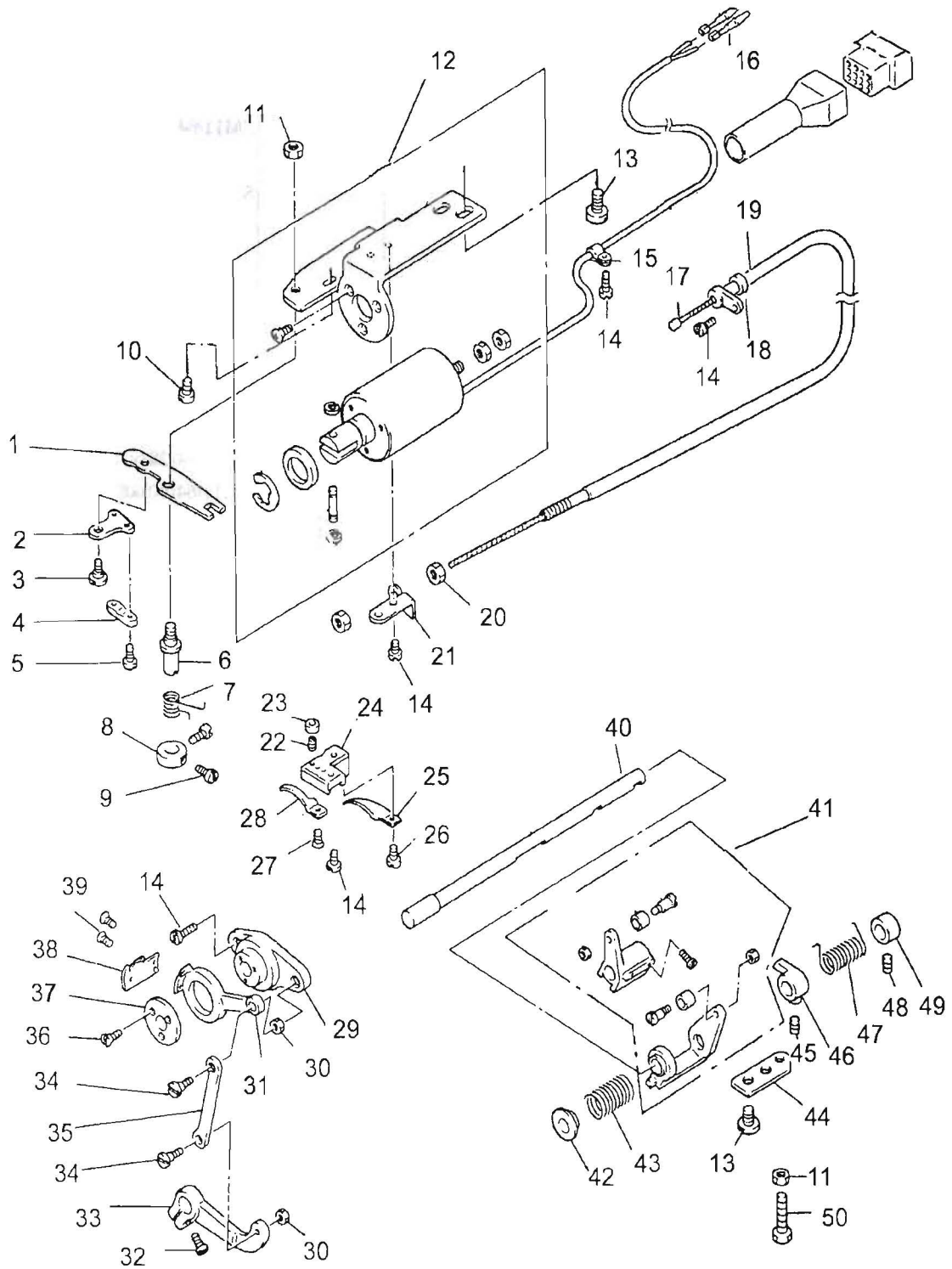



## H.KNIFE ACTUATING MECHANISM

Fig. No.	Part No.	Description	GC0388-D	GC0388	Remarks
H01	HA712N0698	Thread trimmer driving lever	1		
H02	HA712N6910	Flexible wire holder	1		
H03	HA712N0699	Stud screw	1		SM11/64(40)×8
H04	HA712N6911	Flexible wire presser	1		
H05	HA712N6912	Screw	2		SM1/8(44)×7
H06	HA712N0695	Stud screw	1		
H07	HA712N0697	Trimmer lever spring	1		
H08	HA712N0696	Spring support collar	1		
H09	HA7311CC06	Screw	2		SM9/64(40)×8.5
H10	HA100E2150	Screw	1		SM11/64(40)×10
H11	HA710N0683	Nut	1		
H12	H2208H0068	Thread trimmer solenoid	1		
H13	HA700N0080	Screw	4		SM15/64(28)×12
H14	HA300C2030	Screw	7		SM11/64(40)×8
H15	HA708P0668	Cord holder	1		
H16	HA7641B319	Terminal pin	2		
H17	H6005J8001	Flexible wire	1		
H18	HA300H2080	O-ring	1		
H19	H6004J7101	Flexible wire assay	1		
H20	H003003050	Nut	2		GB/T6171 M5
H21	HA712N6913	Holder	1		
H22	HA7121N604	Screw	1		SM9/64(40)×8.5
H23	HA7121N704	Nut	1		SM9/64(40)
H24	HA7121N104	Bracket for fixed blade	1		
H25	H22121H204	Thread guide	1		
H26	HA7311CH06	Screw	1		SM9/64(40)×8
H27	HA7121N304	Screw	1		SM9/64(40)×5
H28	H22121H104	Fixed blade	1		
H29	HA704N1111	Knife holding bracket saddle	1		
H30	HA7111N304	Nut	2		
H31	HA704N1112	Knife base (left)	1		
H32	HA7111N504	Nut	1		
H33	HA7111N604	Knife driving crank	1		
H34	HA7111N204	Screw	2		SM11/64(40)×6.2
H35	HA7111N404	Link	1		
H36	HA704N1114	Screw	3		SM1/8(44)×6
H37	HA704N1113	Thrust washer	1		
H38	H2204H0651	Movable knife (left)	1		
H39	HA7111N704	Screw	2		SM11/64(40)×7
H40	H6006J8001	Knife driving shaft	1		
H41	HA706N0066	Cam follower crank assay	1		
H42	HA700N0050	Bushing	1		
H43	HA700N0040	Coil spring	1		

# H.KNIFE ACTUATING MECHANISM

Fig. No.	Part No.	Description	GC0388-D	GC0388	Remarks
H44	HA710N0682	Lever stopper plate	1		
H45	HA113F0684	Screw	1		SM15/64(28)×11.3
H46	HA709N0671	Stopper	1		
H47	HA700N0110	Coil spring	1		
H48	HA105D0662	Screw	1		SM1/4(40)×4
H49	HA715N0071	Collar	1		
H50	HA7411N110	Screw	1		SM15/64(28)×23

# I.TOUCH BACK & DETECTOR MECHANISM

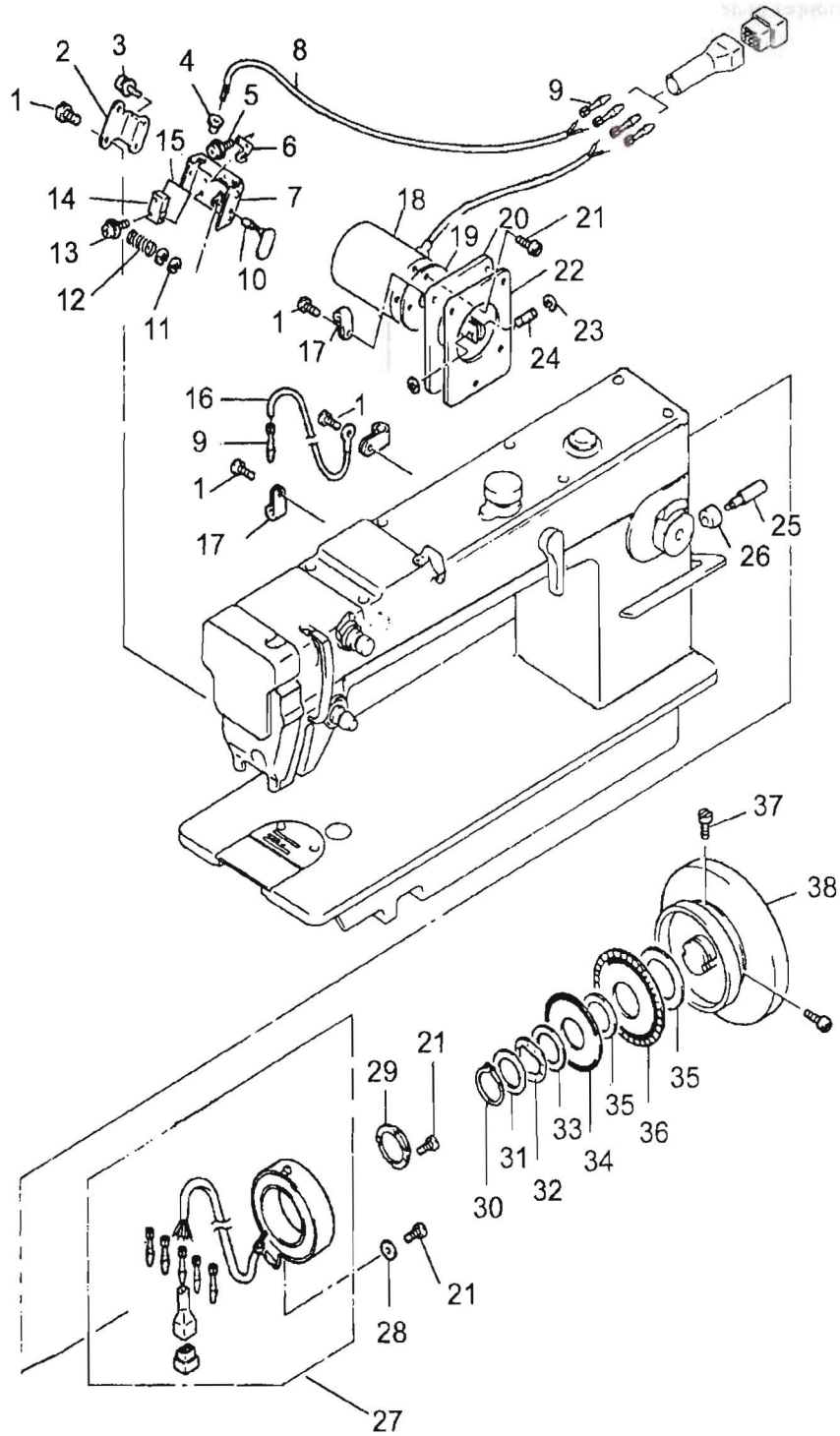

# I.TOUCH BACK & DETECTOR MECHANISM

Fig. No.	Part No.	Description	GC0388-D	GC0388	Remarks
I01	HA300B2160	Screw	8		SM11/64(40)×10
I02	H6005K8001	Bracket	1		
I03	HA7221P508	Screw	2		
I04	HA704O0657	Rubber plug	1		
I05	HA704O0659	Screw	2		
I06	HA704O0654	Spring plate	1		
I07	H2205I0661	Bracket for touch switch	1		
I08	H6006K7101	Vinyl cap-tire cable for touch switch	1		
I09	HA7641B319	Terminal pin (male)	5		
I10	HA704O0021	Push button	1		
I11	H007013030	E-type ring	2		GB/T896 3
I12	HA704O0065	Spring	1		
I13	HA704O6510	Screw	2		M2×8
I14	HA704O0655	Micro switch	1		
I15	HA704O0658	Insulator set	1		
I16	HA705Q0065	Ground wire	1		
I17	HA708P0668	Cord holder	2		
I18	H6009K8001	Solenoid assay for touch back	1		
I19	H2006I0672	Gasket	1		
I20	H6010K8001	Arm side cover	1		
I21	HA300C2030	Screw	7		SM11/64(40)×8
I22	H6011K8001	Gasket	1		
I23	H007013040	E-type ring	2		
I24	HA712N0692	Pin	1		
I25	H6012K8001	Stud screw	1		
I26	H2204G0652	Rubber ring	1		
I27	HA703R0065	Detector bracket assay	1		
I28	HA703R0067	Washer	1		
I29	HA703R0066	Detector bracket supporter	1		
I30	HA111G0683	C-type ring	1	1	
I31	HA700R0060	Washer	1		
I32	HA700R0050	Supporter spring	1		
I33	HA700R0040	Spacer B	1		
I34	HA700R0020	Speed command disc (up)	1		
I35	HA700R0030	Spacer A	2		
I36	HA700R0010	Speed command disc (down)	1		
I37	HA110D0672	Screw	2	2	SM15/64(28)×12
I38	H2204I0651	Pulley	1		
I38	H2000C2040	Pulley		1	

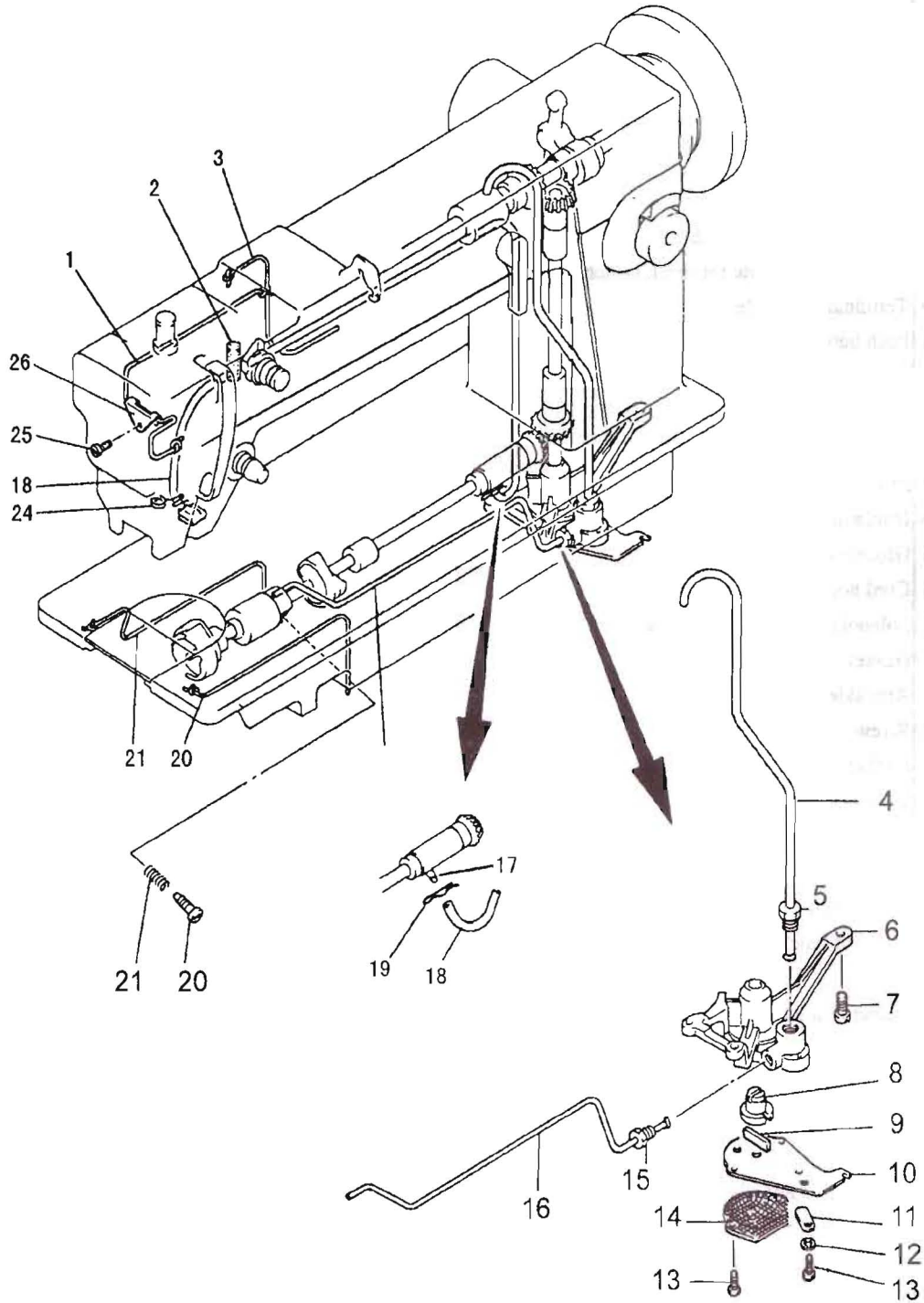

## J.OIL LUBRICATION MECHANISM

Fig. No.	Part No.	Description	GC0388-D	GC0388	Remarks
J01	H6019I8001	Oil wick	1	1	
J02	HA700B2150	Oil felt	1	1	
J03	H6019I8001	Oil wick	1	1	
J04	H6016I8001	Upper shaft oil tube	1	1	
J05	HA116I0682	Bushing	1	1	
J06	H6006I8001	Oil pump	1	1	
J07	HA100I2090	Screw	3	3	SM11/64(40)×13
J08	H6010I8001	Rooter	1	1	
J09	H6011I8001	Slider	1	1	
J10	H6012I8001	Oil pump cover	1	1	
J11	HA100I2070	Oil adjusting plate	1	1	
J12	HA100I2050	Spring washer	1	1	3.5
J13	HA100I2040	Screw	3	3	SM1/8(44)×13
J14	HA111I0065	Oil pump filter	1	1	
J15	HA113I0661	Bushing	1	1	
J16	H6014I8001	Lower shaft oil tube	1	1	
J17	HA110E0672	Oil pipe for lower shaft bushing	1	1	SM1/2(28)
J18	H6018I8001	Oil return tube	1	1	
J19	HA300I2030	Oil return tube clip	1	1	
J20	HA300E2030	Oil adjusting screw	1	1	SM15/64(28)×25.5
J21	HA100E2060	Oil adjusting spring	1	1	
J22	HA305G0664	Oil wick	1	1	
J23	HA304G0655	Oil wick	1	1	
J24	HA300I2060	Oil felt holder	1	1	
J25	HA106B0676	Screw	1	1	SM9/64(40)×6
J26	H6009I8001	Oil wick holder	1	1	

# K.ACCESSORIES

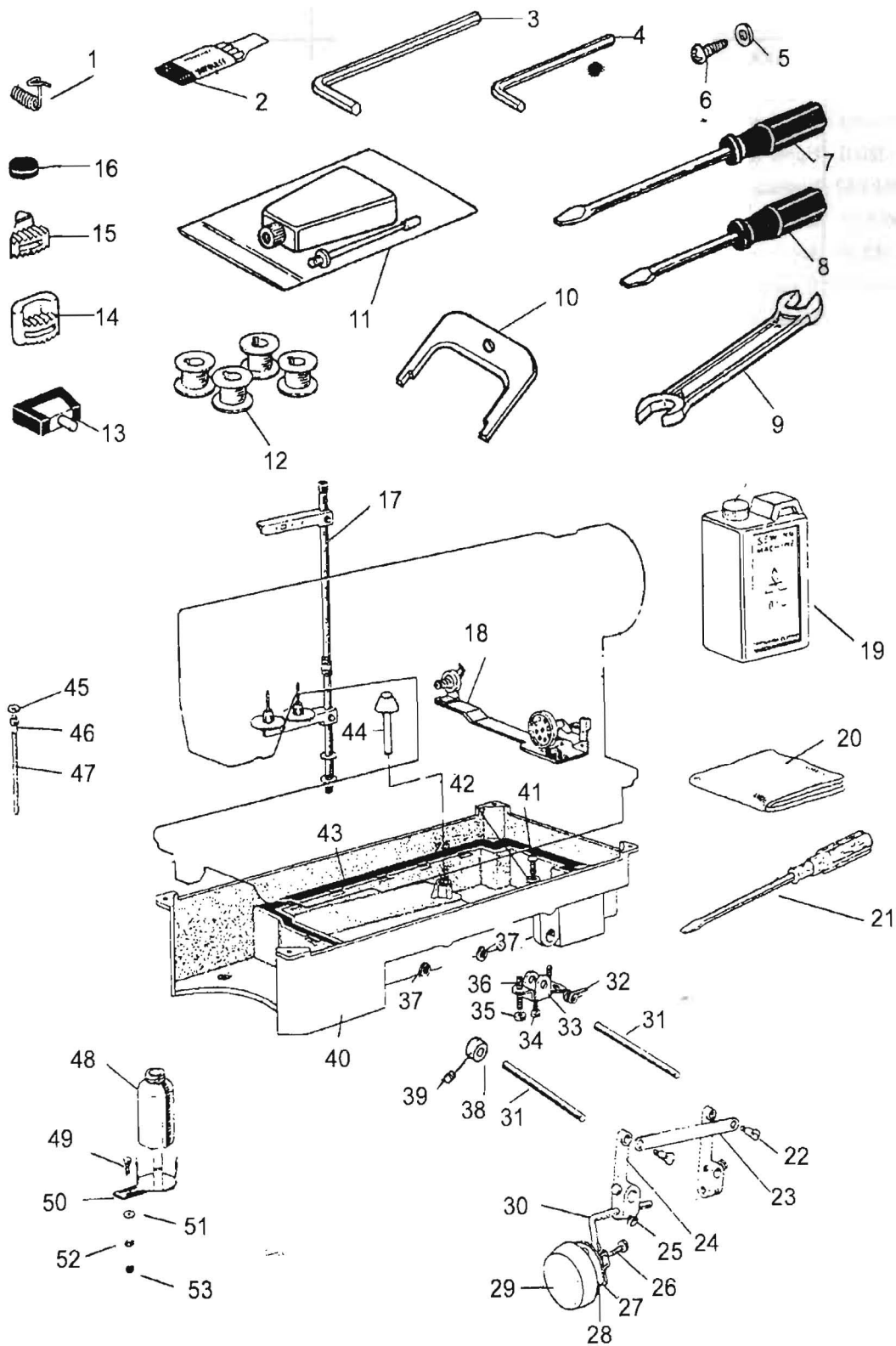

## K.ACCESSORIES

Fig. No.	Part No.	Description	GC0388-D	GC0388	Remarks
K01	HA505B0672	Thread take-up spring	1	1	
K02	H2000G2030	Needle	4	4	DP×17 #22
K03	H3200L0060	Socket wrench 3	1	1	
K04	HA704S0653	Socket wrench 2	1	1	
K05	HA300J2230	Washer for wood screw	4	4	
K06	H801045200	Wood screw	4	4	GB/T99 4.5×20
K07	HA300J2200	Screw driver (middle)	1	1	
K08	HA300J2210	Screw driver (small)	1	1	
K09	HA100J2160	Spanner	1	1	
K10	HA704S0654	Speed command disc adjusting disc	1	1	
K11	HA100J2110	Oil with oiler	1	1	
K12	HA600E2060	Bobbin	4	4	
K13	HA307J0067	Hinge with rubber cushion	2	2	
K14	HA100J2090	Vibration preventing rubber (large)	2	2	
K15	H3200L0030	Vibration preventing rubber (small)	2	2	
K16	HA100J2120	Magnet block	1	1	
K17	HA300J2370	Thread stand assay	1	1	GXJ-2A
K18	HA905S0066	Bobbin winder assay	1	1	
K19	HA300J2170	Oil tank	1	1	
K20	HA100J2180	Cover	1	1	
K21	HA300J2070	Screw driver (large)	1	1	
K22	H6017L8001	Screw	2	2	SM1/4(24)×10.7
K23	H6005L8001	Link	1	1	
K24	H6006L8001	Knee lifter driving crank	2	2	
K25	HA106J0664	Bolt	3	3	SM5/16(18)×13
K26	HA106J0667	Bolt	1	1	SM15/64(28)×8
K27	HA106J0666	Knee lifter plate stopper	1	1	
K28	HA106J0665	Knee lifter plate	1	1	
K29	HA106J0668	Knee lifter cover	1	1	
K30	HA106J0662	Knee lifter shaft	1	1	
K31	H6015L8001	Knee lifter shaft	2	2	
K32	HA104J0657	Coil spring	1	1	
K33	HA104J0658	Knee lifter	1	1	
K34	HA100F2130	Screw	1	1	SM15/64(28)×14.5
K35	HA104J6510	Nut	2	2	SM15/64(28)
K36	HA104J0659	Set screw	2	2	SM15/64(28)×28
K37	H007013090	E-type ring	1	1	GB/T896 9
K38	H6016L8001	Collar	1	1	
K39	HA100C2090	Screw	2	2	SM15/64(28)×4.5
K40	H6008L8001	Oil reservoir	1	1	
K41	HA104J0652	Screw	1	1	SM5/16(28)×10
K42	HA104J0653	Seal washer	1	1	
K43	H6009L8001	Gasket for oil reservoir	2	2	



# K.ACCESSORIES

Fig. No.	Part No.	Description	GC0388-D	GC0388	Remarks
K44	HA106J0661	Knee lifter lifting pin	1	1	
K45	HA600J2060	Gasket	1	1	
K46	HA600J2040	Screw	1	1	
K47	HA600J2050	Drainage tube	1	1	
K48	HA600J2030	Oil bottle	1	1	