

# ARTISAN®



## **618-1 D2** **Operator's Manual** **and** **Spare Parts List**

---

## CONTENTS

1. PRECAUTIONS BEFORE STARTING OPERATION.....	2
2. MAIN SPECIFICATIONS.....	2
3. PREPARATION AND LUBRICATION.....	3
4. REPLACE NEEDLES.....	3
5. WINDING.....	4
6. WINDING ADJUSTMENT.....	4
7. REMOVING AND INSERTING THE BOBBIN.....	4
8. THREADING.....	5
9. REGULATING THE THREAD TENSIONS.....	5
10. ADJUSTMENT OF THE PRESSURE ON THE MATERIAL.....	6
11. ADJUSTING THE LIFT OF THE ALTERNATING PRESSER FEET.....	6
12. STITCH LENGTH ADJUSTMENTS AND REVERSING LEVER.....	6
13. ADJUSTING THE HEIGHT OF THE FEED DOG.....	6
14. RELATIVE POSITION OF THE FEED DOG TO NEEDLE PLATE.....	7
15. THE POSITION OF THE NEEDLE AND THE NEEDLE HOLE OF THE FEED DOG.....	7
16. TIMING THE NEEDLE WITH FEED DOG.....	7
17. ADJUSTING THE HEIGHT OF THE NEEDLE BAR.....	8
18. TIMING BETWEEN THE HOOK AND THE NEEDLE.....	8
19. ADJUSTING THE HEIGHT OF THE PRESSER FEET.....	8
20. TIMING OF THE VIBRATING PRESSER FOOT.....	9
21. ADJUSTMENT OF THE CLEARANCE BETWEEN FEED FORKED CONNECTION AND FEED FORK COLLAR .....	9
22. ADJUSTING THE THREAD CONTROLLER SPRING.....	9
23. ADJUSTMENT OF NEEDLE BAR STOP POSITION.....	9
24. ADJUSTMENT OF KNIFE ENGAGEMENT.....	10

# 1. PRECAUTIONS BEFORE STARTING OPERATION

## 1) Safety Precautions:

- (1) When turning the power on, keep your hands and fingers away from the area around/under the needle and the area around the balance wheel.
- (2) Power must be turned off when the machine is not in use, or when the operator leaves the seat.
- (3) Power must be turned off when tilting the machine head, installing or removing the "V" belt, adjusting the machine, or when replacing.
- (4) Avoid placing fingers, hairs, bars etc., near the balance wheel, "V" belt, bobbin winder balance wheel, or motor when the machine is in operation.
- (5) Do not insert fingers into the thread take-up cover, under/around the needle, or balance wheel when the machine is in operation.
- (6) If a belt cover, finger guard, eye guard are installed, do not operate the machine without these safety devices.

## 2) Precautions before Starting Operation:

- (1) If the machine's oil pan has an oil sump, never operate the machine before filling it.
- (2) If the machine is lubricated by a drop oiler, never operate the machine before lubricating.
- (3) When a new sewing machine is first turned on, verify the rotational direction of the balance wheel with the power on. (The balance wheel should rotate counter-clockwise when viewed from the balance wheel)
- (4) Verify the voltage and (single or three) phase with those given on the machine nameplate.

## 3) Precautions for Operating Conditions:

- (1) Avoid using the machine at abnormally high temperature (35°C or higher) or low temperature (5°C or lower)
- (2) Avoid using the machine in dusty conditions.

# 2. MAIN SPECIFICATIONS

Item	618 I	618 I SC	618 I D2	518 I
Max. Sewing Speed	2000 rpm			
Stitch Length	0-10 mm			
Take-up Lever Stroke	71.5 mm			
Needle Bar Stroke	35 mm			
Height of Between Main and Sub Presser Foot	2.5 mm			
Presser foot lift	By Hand	8 mm		
	By Knee	14mm		
Needle	DP×17 22# 24#			
Rotating Hook	Double Capacity Hook	Large Hook for Trimmer	Double Capacity Hook	
Lubrication	Manual			
Motor	370W Clutch Motor	Speed adj. Motor	370W Clutch Motor	

### 3. PREPARATION AND LUBRICATION

#### 1) Cleaning the machine

Before leaving the factory, the machine parts are coated with rust-preventive grease, which may be hardened and contaminated by dust during storage and shipment. This grease must be removed with gasoline.

#### 2) Examination

Though every machine is confirmed by strict inspection and test before leaving the factory, the machine parts may be loose or deformed after long distance transportation with jolt. A thorough examination must be performed after cleaning the machine. Turn the balance wheel to see if there is running obstruction, parts collision, uneven resistance or abnormal noise. If these exist, adjustment must be made accordingly before run-in operation.

#### 3) Oiling (Fig.1, 2, 3, 4)

Please do not operate the machine before lubricating well. The points with arrow in the fig are oil positions.

**Caution:** Please use white spindle oil.

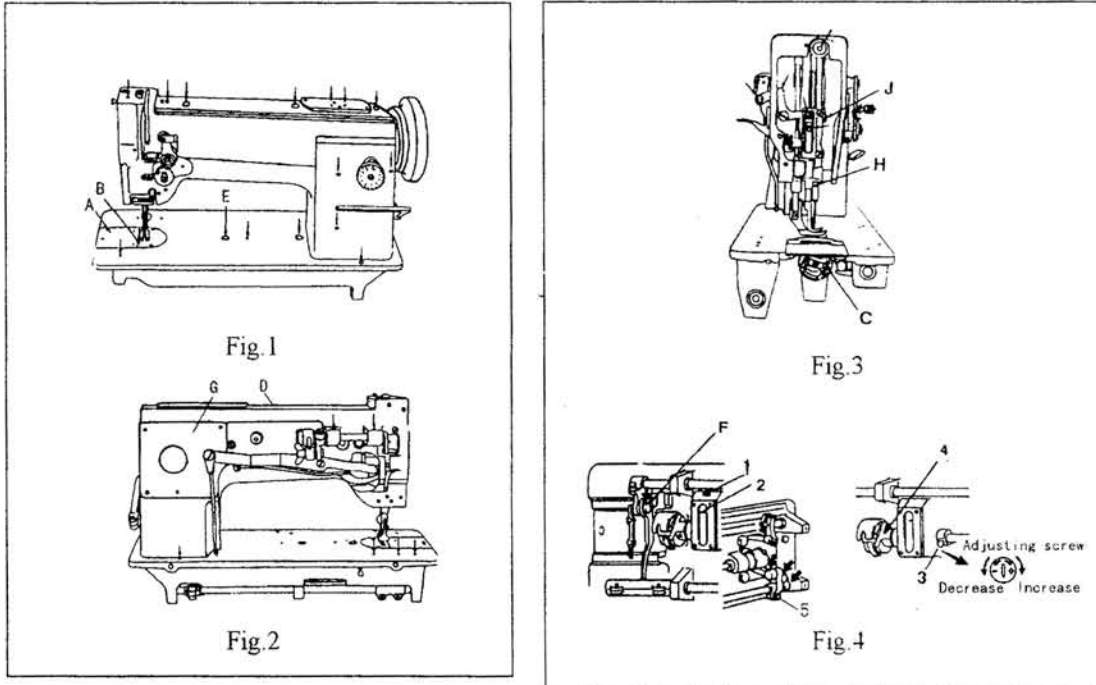

Lubrication of rotating hook (Fig.4)

Add the oil from the oil hole 1 until to the position 2.

Adjusting the lubrication (Fig.4)

Oil adjusting screw 3 can adjust the lubrication of the rotating hook: Turn oil-adjusting screw 3 clockwise to increase oil and turn oil-adjusting screw 3 counter-clockwise to decrease oil.

### 4. REPLACE NEEDLES (Fig.5)

1) Turn the balance wheel to lift needle bar 1 to the upper end of its stroke.

2) Loosen needle clamp screw 2. While keeping the long groove of the needle leftward fully insert the needle shank up to the bottom of the needle socket.

**Caution:** The direction of the long groove should be left.

3) Then tighten needle clamp screw 2.

## 5. WINDING (Fig.6)

1) Put the bobbin 3 on the bobbin winder shaft as far as it will go.

2) Bring the thread forward toward the bobbin and wind from below in clockwise direction several times around the bobbin.

4) Push the lever 4 toward other side so that the winding wheel and "V" belt will engage and then start the machine.

5) The winding wheel will automatically be free from "V" belt and stop after the bobbin is filled with thread.

## 6. WINDING ADJUSTMENT (Fig.6)

1) When the wound thread layer does not present a cylindrical shape, loosen set screw 5 of bobbin winder tension bracket and slide bracket leftward or rightward. After adequately positioning the bracket, tighten set screw 5.

2) Do not overfill the bobbin. The optimum length of thread will fill about 80% of bobbin capacity. This can be adjusted by adjusting screw 6 of bobbin winder stop latch.

3) Adjusting of the winding tension: The winding tension can be adjusted by tension screw 7.

## 7. REMOVING AND INSERTING THE BOBBIN

1) Turn the balance wheel to lift needle bar 1 to the upper end of its stroke. Place the feed dog at this side in its travel turning the balance wheel, and open the slide plate A. (Fig.1)

2) Open on the drip pan, and then open the hinged latch with left thumb and index finger. And pull bobbin case and bobbin from rotary hook. While the latch is held open, the bobbin will be retained in the bobbin case. Release of the latch and turning of the open side of the bobbin case downward will cause the bobbin to drop out.

3) Hold the bobbin between the thumb and forefinger of your right hand and pull out a length of about 5 cm of thread. Holding the bobbin case in your left hand turn the open side up and place the threaded bobbin into it. (Fig.7)

4) With the right hand guide the thread into the slot in the edge of the bobbin case. Then pull the thread to the left, under tension spring 1 (Fig.7) and into the delivery eye. In order to keep the bobbin from dropping out of the case when it is turned with the open side down, always keep the hinged latch at the front of the bobbin

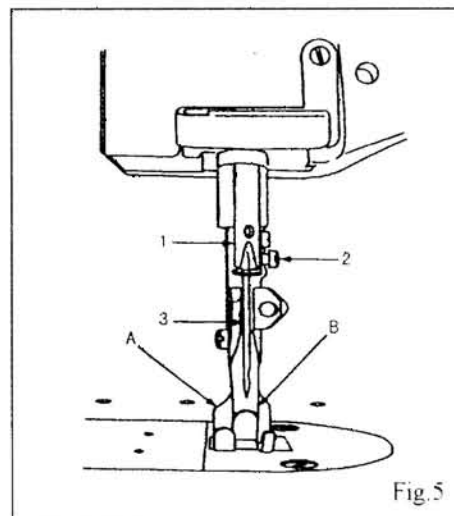

Fig.5

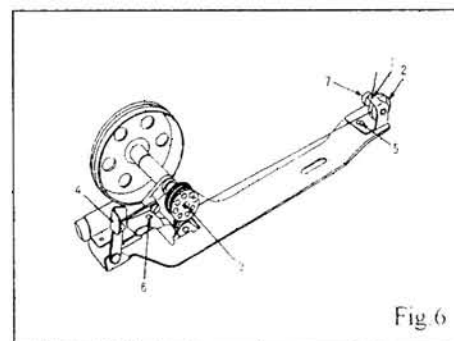

Fig.6

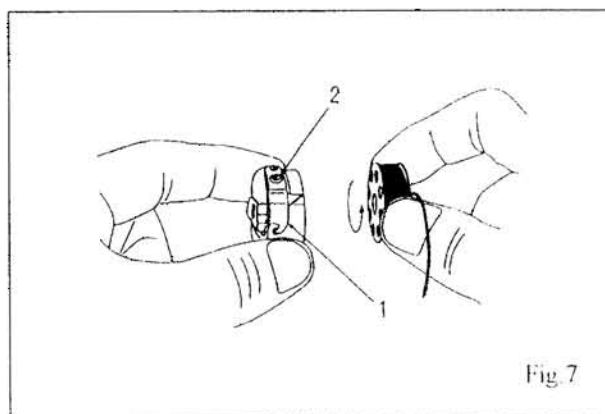

Fig.7

case open.

5) Take the threaded bobbin case by the latch and place it on the center stud of the bobbin case holder. Release latch and press bobbin case on to center stud until the latch catches the undercut thereon with a click that can be heard. Permit about 5 cm of bobbin thread to hang down freely. Be sure to push the slide plate to the right before starting to sew.

## 8. THREADING (Fig.8)

1) Raise the needle bar to its highest point and lead the thread from the thread stand the following order. From the thread stand lead the thread from back to front through the lower guide hole in pin 1 on top of the machine arm, then again from right to left through the upper guide hole in this pin. Pass thread in weaving fashion through the three holes in guide 2, and from right to left over and between the tension disc 3. Now pull thread downward and from right to left beneath and around thread controller 4, continue to pull thread upward against the pressure of the wire spring into the fork 5, in the thread controller. Guide upward through the point of controller discs 6, and thread guide 7, and from right to left through the eye in take-up lever 8, down through thread guide 7, again and then through 9, 10, 11 and from left to right through the eye of the needle 12.

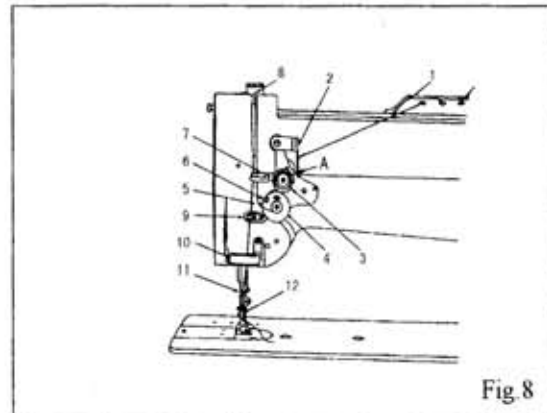

Fig.8

2) After the above threading, hold the end of thread with your left hand, and turn the balance wheel with your right hand so that bobbin thread may be picked up by needle thread. And put their ends of thread back through under the presser foot for starting operation.

## 9. REGULATING THE THREAD TENSIONS

For ordinary stitching, the tension of the upper and the lower threads should be equal so as to lock both threads in the center of the material. (1 Fig.9) If the tension on either thread is stronger than on the other, imperfect stitching will be the result. If the tension on the upper thread is greater than that on the lower thread, it will lie straight along the upper surface of the material. (2 Fig.9) If the tension on the lower thread is greater than that on the upper thread, the lower thread will lie straight along the underside of the material. (3 Fig.9)

1) Tension of the upper (needle) thread:

Before adjusting the tension of the upper (needle) thread, be certain that the presser foot is let down but not in lifted position. To adjust tension, turn serrated nut (A Fig.8) on tension device to clockwise to increase tension, while turning it to counter-clockwise to decrease it.

2) Tension of the lower (bobbin) thread: (Fig.7)

The lower (bobbin) thread tension is controlled by the larger screw (2 Fig.7) near the end of the spring at the outside of the bobbin case. Turning this screw to clockwise to increase the thread tension, while turning it to counter-clockwise to decrease it.

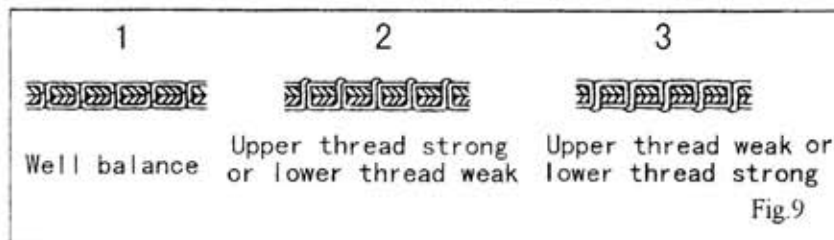

## 10. ADJUSTMENT OF THE PRESSURE ON THE MATERIAL

The pressure of the presser feet is adjusted by the screw D (Fig.2) with screwdriver. To increase the pressure, turn the screw to clockwise and to counter-clockwise to decrease it.

## 11. ADJUSTING THE LIFT OF THE ALTERNATING PRESSER FEET

### (Fig.10)

The thickness of the material should control the height of the lift of the alternating presser feet. The lift should be just enough for clearance of the material.

1) With normal adjustment both feed lift to equal height: To later lift, loosen the wing nut A and move the link and stud assembly along the slot-move up to raise the feeding presser foot and push down to lower this foot. Tighten wing nut upon completion of adjustment. However, some materials may require unequal height of lift.

2) When altering the lift of the lifting presser foot (A Fig.5) unequally against that of the vibrating presser foot (B Fig.5) or vice versa, see the instructions " ADJUSTING THE HEIGHT OF THE PRESSER FEET "

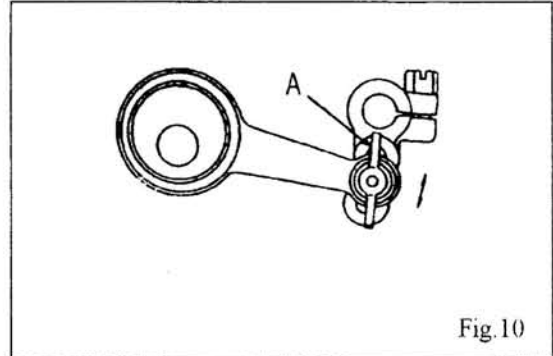

Fig.10

## 12. STITCH LENGTH ADJUSTMENTS

### AND REVERSING LEVER (Fig.11)

Stitch length can be set by turning the detail 2. Numeric figures on the dial show the stitch length in mm. The desired numeric figure on the dial should be set at just above, while depressing the reversing lever 1 slightly.

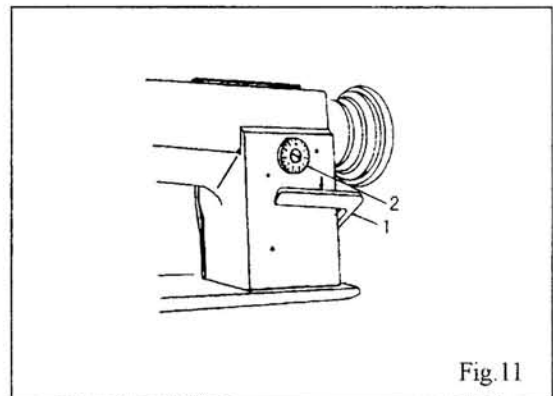

Fig.11

## 13. ADJUSTING THE HEIGHT OF

### THE FEED DOG (Fig.12)

The maximum height of the feed dog (1 Fig.12) from the surface of the needle plate (2 Fig.12) is normally 1 mm.

1) Lay down the machine head toward the other side, and turn the balance wheel so as to raise the feed dog to it highest point.

2) Loosen bell crank screw F (Fig.4) and adjust the height of the feed dog by raising or lowering it.

3) Securely tighten the screw upon completion of adjustment.

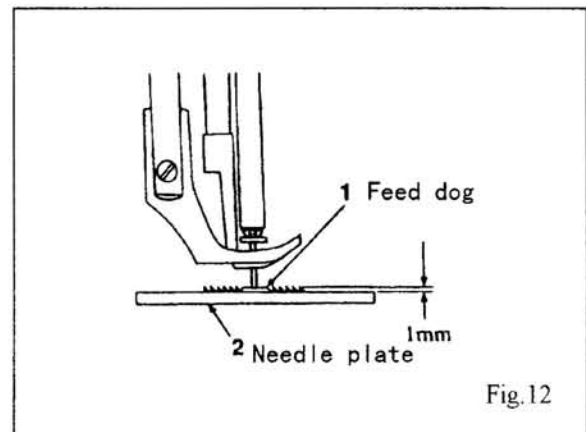

Fig.12

## 14. RELATIVE POSITION OF THE FEED DOG TO NEEDLE PLATE

### (Fig.13)

- 1) Set the stitch length at minimum.
- 2) Turn the balance wheel so as to raise the feed dog to its highest point.
- 3) Lay down the machine head toward the other side and loosen the screw 5 (Fig.4).
- 4) Adjust to be 32.1 mm from the edge of the needle plate to the center of the needle hole on the feed dog. (Fig.13)
- 5) Securely tighten the screw.

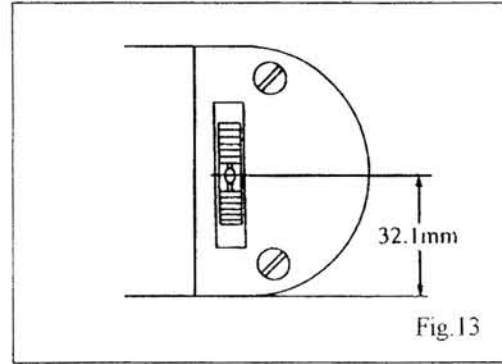

Fig.13

## 15. THE POSITION OF THE NEEDLE AND THE NEEDLE HOLE OF THE FEED DOG

Turning the balance wheel to lower slowly the needle bar, check whether the needle descends to the center of the needle hole of the feeder or not. (Please check again the needle is perfect one.)

- 1) Remove the cover G (Fig.2) and loosen the screw 1 (Fig.14) slightly.
- 2) Holding the bottom of the needle bar rock frame H (Fig.3), move it as may be required to get the correct position to the feed dog.
- 3) Tighten the screw and close the cover.

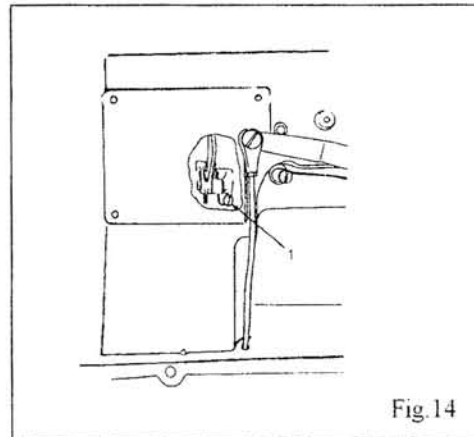

Fig.14

## 16. TIMING THE NEEDLE WITH FEED DOG (Fig.15, Fig.16)

It is important that the timing relationship between the needle on its downward stroke and the feed dog movement is maintained at all times. When the scarf of the needle on the downward stroke reaches the top surface of the feed dog, the feed dog movement must start. When adjustment is required, use the following procedure to change the position of cam

- 1) Loosen the screw 1 for cover plate 2 and then remove the cover plate 2.
- 2) Normally put the arrow mark 7 of the cam 6 on the V ditch 5 of arm shaft. Then tighten the cam screw.
- 3) Turn the balance wheel to the needle at 1 mm up from its lowest point.
- 4) Pushing the stitch length regulating lever up and down, turn the cam 6 and set this at the point both the needle and the feed dog rest. After positioning completed, tighten the each screw securely

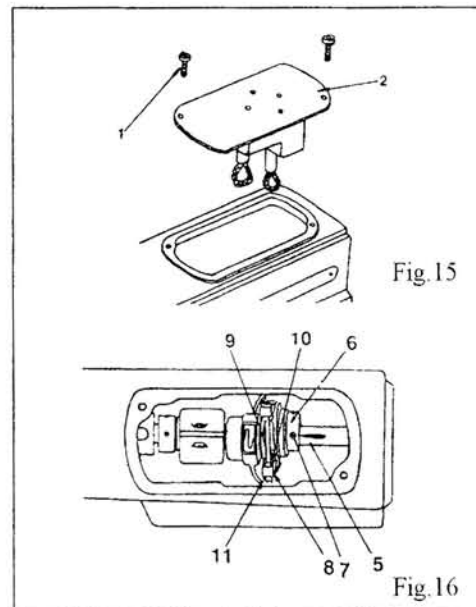

Fig.15

Fig.16



## 17. ADJUSTING THE HEIGHT OF THE NEEDLE BAR (Fig.17)

When the needle bar is at its highest point, normally the measurement between the surface of the needle plate and the upper end of the needle eye is 22.3 mm.

You can also adjust this at its lowest point. In this case, normally the measurement between the surface of the needle plate and the upper end of the needle eye is 11 mm. To adjust this, loosen the screw J (Fig.3) and raise or lower the needle bar as may be required. Then, tighten the screw upon completion of adjustment.

NOTE: These measurements are approximate standard, accordingly, following final adjustments "TIMING BETWEEN THE HOOK AND THE NEEDLE" are recommended.

## 18. TIMING BETWEEN THE HOOK AND THE NEEDLE (Fig.18, Fig.19)

After setting the needle bar height, set stitch length to minimum, turn the balance wheel toward you until the needle bar reaches its lowest point. Continue turning and allow the needle bar to raise about 2 mm while on its upward stroke. With needle bar in this position, the point of the sewing hook should be at the center of the needle, and normally, the measurement between the hook point and the upper end of the needle eye should be 2.4 mm, further the clearance between the hook point and the needle hollow should be about 0.05 to 0.1 mm.

1) If the sewing hook should not be timed correctly, loosen the three set screws. Turn the hook shaft to align the hook point with the center of the needle. Re-tighten the three set screws and re-check the timing of the sewing hook.

2) To adjust the clearance between the hook point and the needle hollow, loosen the two screws and move the hook to the right or to the left as may require. Please note one of the two screws is placed on the V ditch of hook shaft. Therefore, keep the screw on V ditch during adjustment. Re-tighten the screws.

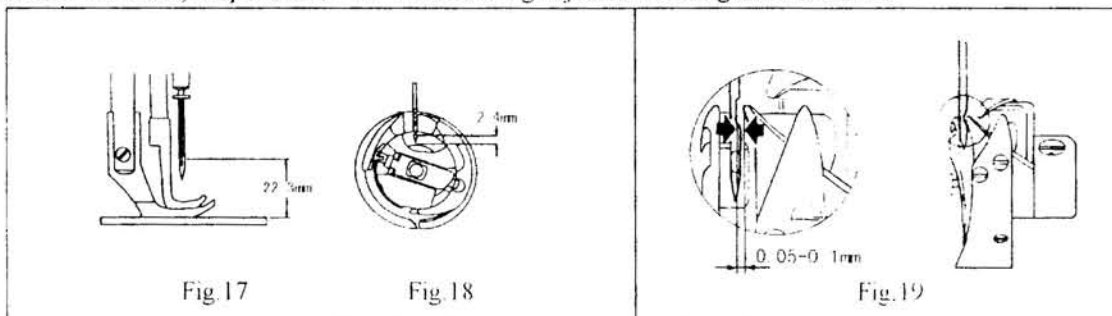

## 19. ADJUSTING THE HEIGHT OF THE PRESSER FEET (Fig.20)

1) Adjustment by the presser bar lifter: Loosen the screw 1 sufficiently, raise the presser bar lifter and loosen the set screw 2. Move the lifting presser foot up or down as may be required so as to get the correct height and tighten the screws.

2) Adjusting the lift of alternating presser feet: If the height of the lifting presser foot changes, the momentums of the lifting and vibrating presser foot vary, thus the height of the vibrating presser foot must be adjusted. To adjust this, lower the presser bar lifter, holding the vibrating presser foot B (Fig.6) and loosen the hexagon screw 3 and move the presser foot up or down as may be required. After setting the position, tighten the screw.

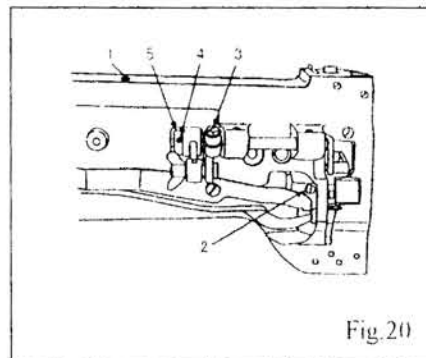

## 20. TIMING OF THE VIBRATING PRESSER FOOT

This is the normal timing when turn the balance wheel toward you, after lowering the presser bar lifter, the vibrating presser foot should reach the feed dog earlier than the needle eye comes to, and when the needle raises, the vibrating presser foot should leave the feed dog after the needle eye has left the feeder. This is due the reason that the vibrating presser foot must tightly hold the goods while the needle is passing the goods for avoiding irregular stitches. To adjust this, set the lift of the alternating presser feet to equal, loosen the two screws 4 (Fig.20) and adjust the rotating position of the cam 5 (Fig.20) faster or slower as may be desired, and tighten the screws.

## 21. ADJUSTMENT OF THE CLEARANCE BETWEEN FEED FORKED CONNECTION AND FEED FORK COLLAR (Fig.15, Fig.16)

Incorrect clearance between the fork 8 of feed forked connection and feed fork collar 9 will bring irregular stitch length or overheating, etc. To adjust this, open the cover plate. Remove the cover plate and the oil reservoir. To increase the clearance, loosen the screw and turn the screw to left or counter-clockwise. This adjustment should be done with turning the balance wheel toward you to get correct clearance. Upon completion of adjustment, tighten the screw which is loosened to touch the feed fork.

## 22.ADJUSTING THE THREAD CONTROLLER SPRING (Fig.21)

Normally, the thread controller spring 1 should hold slack of the upper thread until the needle reaches to the goods, and it should pause while raising of the needle and passing of the upper thread through the bobbin case.

1) For more controller action on the thread: Loosen the stop screw 2, move the stop to the right (For less action, move to the left). Tighten the screw.

2) To adjust the tension spring: Loosen the serrated nut 4 and the screw 5. Turn the tension stud 6 slightly to the left to strengthen the tension (to lighten the tension, turn to the right) with a screwdriver. Tighten the screw and nut upon completion of adjustment.

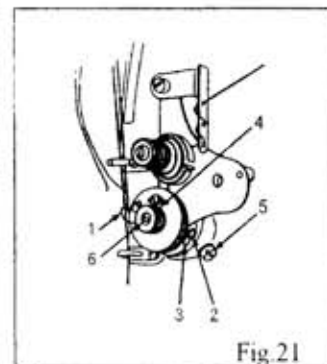

## 23.ADJUSTMENT OF NEEDLE BAR STOP POSITION

(Fig. 22, 23)

### 1) Adjusting of "Up" position

When the pedal is kicked down by heel, the machine stops at "UP" position. If the marks deviate larger than 3 mm adjust as follows:

- (1) Disconnect the plug (12 pins) of cable from the machine head.
- (2) Run the machine and stop at "UP" position.
- (3) While holding the balance wheel insert the "adjusting tool" in the hole A, then remove the tool.

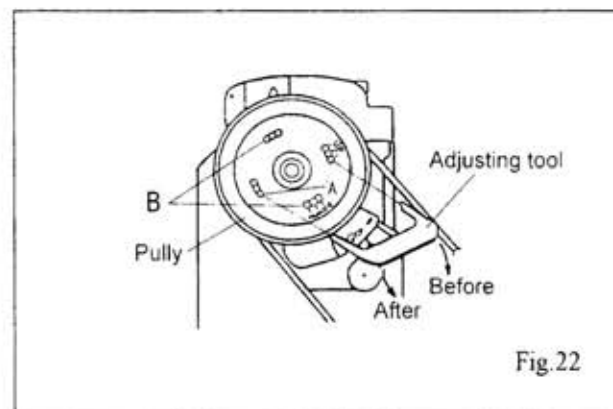

## 2) Adjusting of "DOWN" position

Set the machine stops at "DOWN" position. When the pedal is kicked down by heel, the machine stops as "DOWN" position. If the marks deviate larger than 3 mm adjust as follows:

- (1) Disconnect the plug (12 pins) of cable from the machine head.
- (2) Run the machine and stop at "DOWN" position.
- (3) While holding the balance wheel insert the "adjusting tool" in the hole B, then remove the tool.

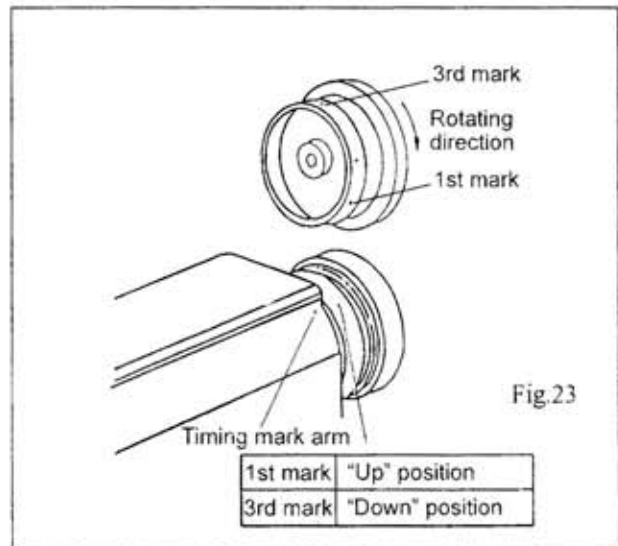

Fig.23

3) Confirm the stop operation then the plug (12 pins) coming from the machine head into the receptacle.

## 24. ADJUSTMENT OF KNIFE ENGAGEMENT (Fig.24)

### 1) Position of movable knife (left) and fixed blade:

See the illustration. The standard distances from the needle center are 7.5 mm and 7 mm from the movable knife (left) and fixed blade respectively.

### 2) Adjustment of knife engagement:

With the solenoid activated, turn on the machine. This rotates the thread trimming cam which rotates the movable knife (left). When the movable knife (left) has moved to its farthest distance, the standard engagement of the blade is 1.5-2.0 mm.

### 3) Adjustment of knife engaging pressure

If a thread is poorly cut, particularly when it is thick, slightly increase the engaging pressure. This should solve the problem. The engaging pressure can be adjusted in this way: Loosen lock nut B and adjust it by using adjusting screw A

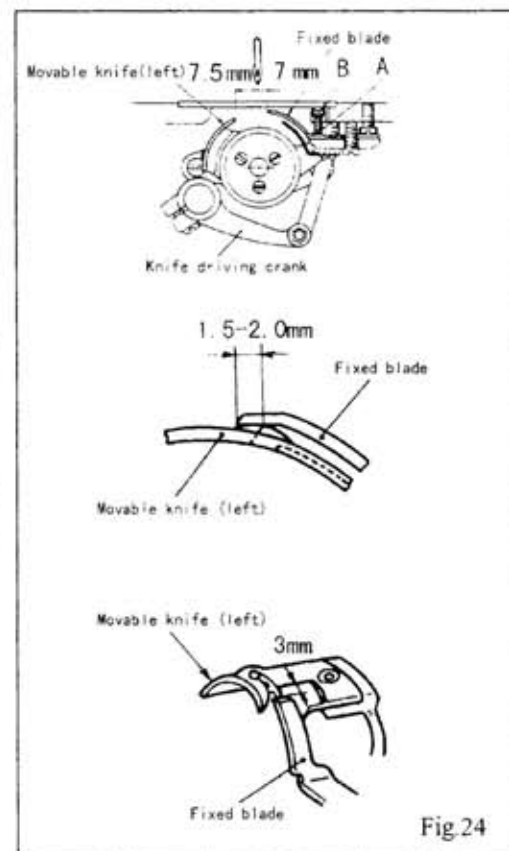
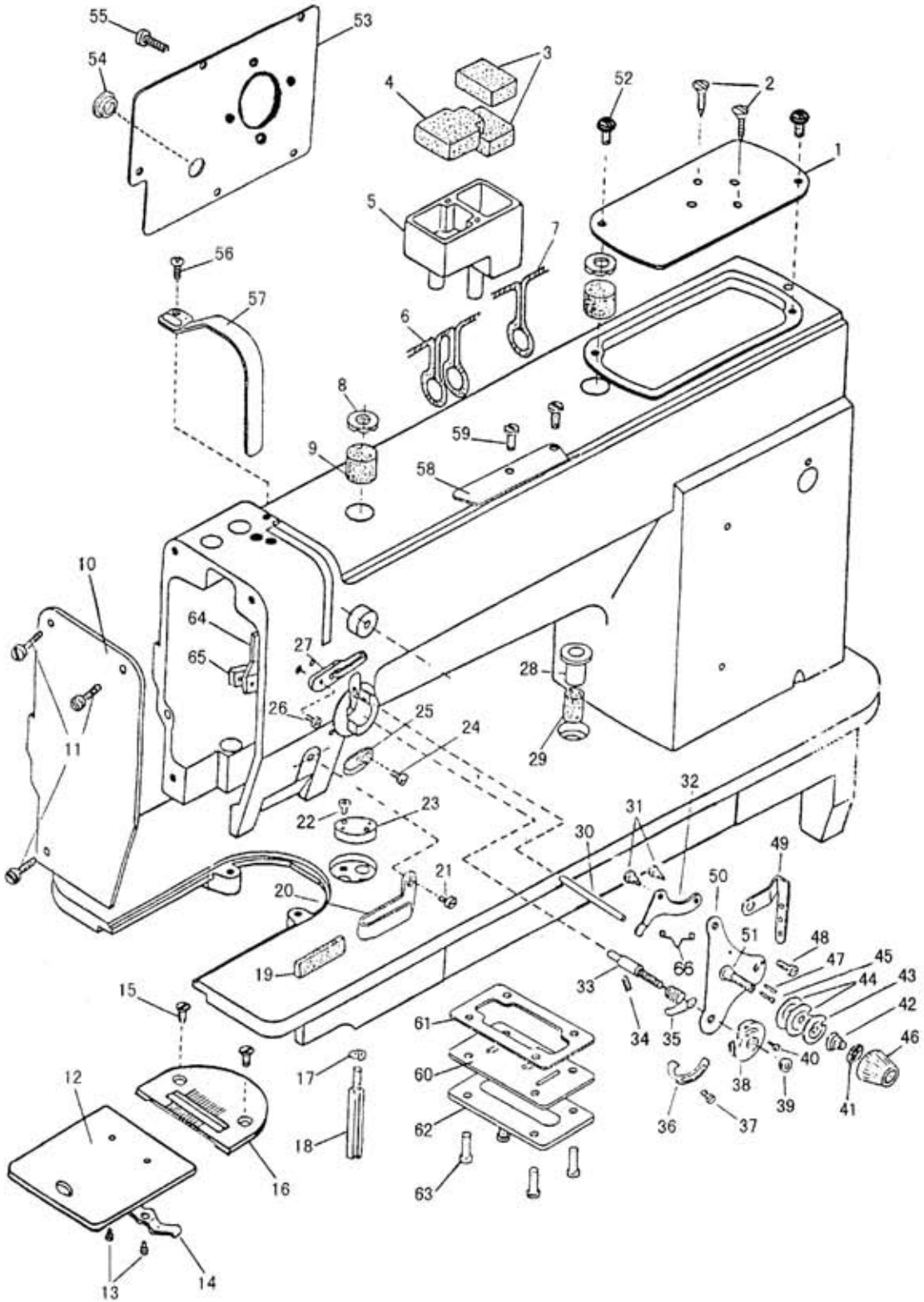

Fig 24

# A.ARM BED AND ITS ACCESSORIES



## A.ARM BED AND ITS ACCESSORIES

Fig. No.	Part No.	Description	618-1-D2	Remarks
A01	H3115B0721	Arm cover(right)	1	
A02	HA06030080	Screw	2	
A03	H2020M0069	Felt	1	
A04	H2020M0067	Felt	2	
A05	H2020M0066	Arm oil box(right)	1	
A06	H2020M0068	Oil wick	1	
A07	H2020M0068	Oil wick	1	
A08	H2400J2010	Oil cap	1	
A09	H2400J2020	Oiling felt	1	
A10	H3106B0671	Face plate	1	
A11	HA300B2170	Screw	2	SM11/64(40)×9
A12	HA124B0711	Slide plate	1	
A13	HA124B0713	Screw	2	SM3/32(56)×2.2
A14	HA124B0712	Slide plate spring	1	
A15	H2000B2050	Screw	2	SM11/64(40)×6.5
A16	H3100B2090	Needle plate	1	
A17	H005008060	Spring washer	1	
A18	H2009B0653	Leg	1	
A19	H3108B0692	Felt	1	
A20	H3108B0691	Thread guide	1	
A21	HA500C2070	Screw	1	SM9 64(40)×5
A22	HA300B2130	Screw	2	SM11. 64(40)×5.5
A23	H2000B2040	Cloth guide plate	1	
A24	HA106B0676	Screw	1	SM9/64(40)×6
A25	HA106B0675	Thread guide	1	
A26	H2400B2080	Screw	1	SM3/16(28)×13
A27	H2400B2070	Thread guide	1	
A28	H2000M0090	Oil cap	1	
A29	H2000M0080	Felt	2	
A30	H4200G2010	Thread tension releasing pin(long)	1	
A30	H4200G2020	Thread tension releasing pin(short)	1	
A31	H2504C6510	Screw	2	
A32	H3111B0704	Tension releasing lever	1	
A33	H31611B311	Screw	1	
A34	HA300B2080	Screw	1	SM15/64(28)×6.8
A35	H3111B0702	Thread controller spring	1	
A36	H3221B6819	Thread controller spring stop	1	
A37	H32481BC21	Screw	1	
A38	H2504C0654	Thread guide	1	
A39	H2504C0658	Nut	1	
A40	H3111B0703	Ser screw	1	SM3/32(56)×6

## A.ARM BED AND ITS ACCESSORIES

Fig. No.	Part No.	Description	618-1-D2	Remarks
A41	HA115B7010	Stop disc	1	
A42	HA607B0068	Tension releasing spring	1	
A43	H2504C0657	Thread tension releasing plate	1	
A44	H2504C0656	Thread tension disc	2	
A45	H2504C0121	Thread tension releasing pin	1	
A46	HA310B0701	Nut	1	
A47	H31611B211	Pin	1	
A48	HA7311C606	Screw	1	
A49	H3100B2070	Thread guide	1	
A50	H31611B111	Tension bracket	1	
A51	H2504C0013	Thread tension stud	1	
A52	HA300B2170	Screw	2	SM11/64(40)×9
A53	H4205I0661	Arm side plate	1	
A54	H2000B2010	Rubber plug	1	
A55	HA300B2170	Screw	5	
A56	HA300B2160	Screw	1	SM11/64(40)×10
A57	H3100B2060	Thread take-up lever cover	1	
A58	H4206B0066	Thread tension complete	1	
A60	H2000M0180	Oil window	1	
A61	H2000M0190	Sealing washer	1	
A62	H2000M0200	Gland	1	
A63	HA300B2170	Screw	5	SM11/64(40)×9
A64	H2400B2050	Oil guard	1	
A65	H2400B2060	Plate for oil guard	1	
A66	H3111B0705	Plate spring	1	

# B.ARM SHAFT MECHANISM

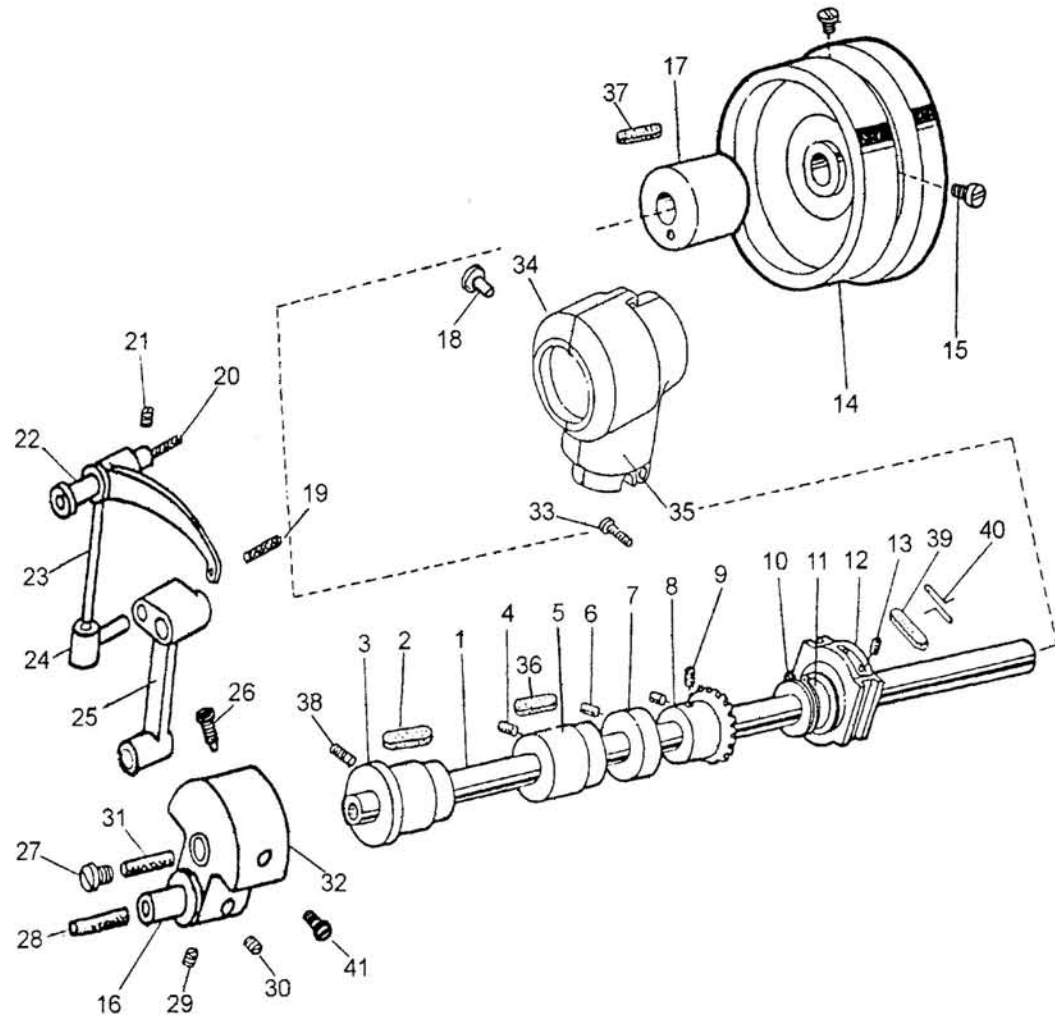

## B.ARM SHAFT MECHANISM

Fig. No.	Part No.	Description	618-I-D2	Remarks
B01	H3100C2110	Arm shaft	1	
B02	H2009B0743	Felt	1	
B03	H31133B104	Arm shaft bushing(left)	1	
B04	HA100C2020	Screw	1	SM15/64(28)×10
B05	H31122B204	Arm shaft bushing(middle)	1	
B06	HA105D0662	Screw	2	SM1/4 (40) ×4
B07	HA105D0661	Arm shaft collar	1	
B08	HA113D2112	bevel gear for arm shaft	1	
B09	HA108D0663	Set screw	8	SM1/4(40)×7
B10	HA112D3012	C-type ring	1	
B11	H3100E2010	Feed and feed lifting eccentric	1	
B12	HA3411D208	Slide block	1	
B13	HA3411D308	Screw	2	
B16	H3100C2070	Hinge pin	1	
B17	H2009B0732	Arm shaft bushing(right)	1	
B18	HA300B2110	Rubber plug	1	
B19	H3100C2050	Oil wick	1	
B20	H3100C2030	Oil wick	1	
B21	HA100C2020	Screw	1	SM15/64(28)×10
B22	H3100C2020	Hinge pin	1	
B23	H3100C2010	Thread take-up lever	1	
B24	H3100C2040	Slide lever	1	
B25	H4200C2060	Needle bar connecting stud	1	
B26	H4206C8001	Screw	1	SM9/32 (28)
B27	H3100C2130	Arm shaft oil packing stop screw	1	
B28	H3100C2080	Oil wick	1	SM1/4 (40) ×4 SM1/4 (40) ×7
B30	HA307C0662	Set screw	2	SM1/4 (40) ×6
B31	H3100C2120	Oil wick	1	
B32	H4204C0651	Needle bar crank	1	
B33	H409050140	Screw	2	
B34	H2017M0067	Bevel gear cover(up-backward)	1	
B35	H2017M0065	Bevel gear cover(up-forward)	1	
B36	H31122B104	Felt	1	
B37	H2009B0731	Felt	1	
B38	HA100C2020	Screw	1	SM15/64(28)×10
B39	H20111C206	Felt	1	



## B.ARM SHAFT MECHANISM

Fig. No.	Part No.	Description			618-1-D2		Remarks
B40	H20111C106	Oiling felt presser pin			1		
B41	H4204C0652	Screw			1		SM9/32 (28) ×12

# C.ROTATING HOOK SHAFT MECHANISM

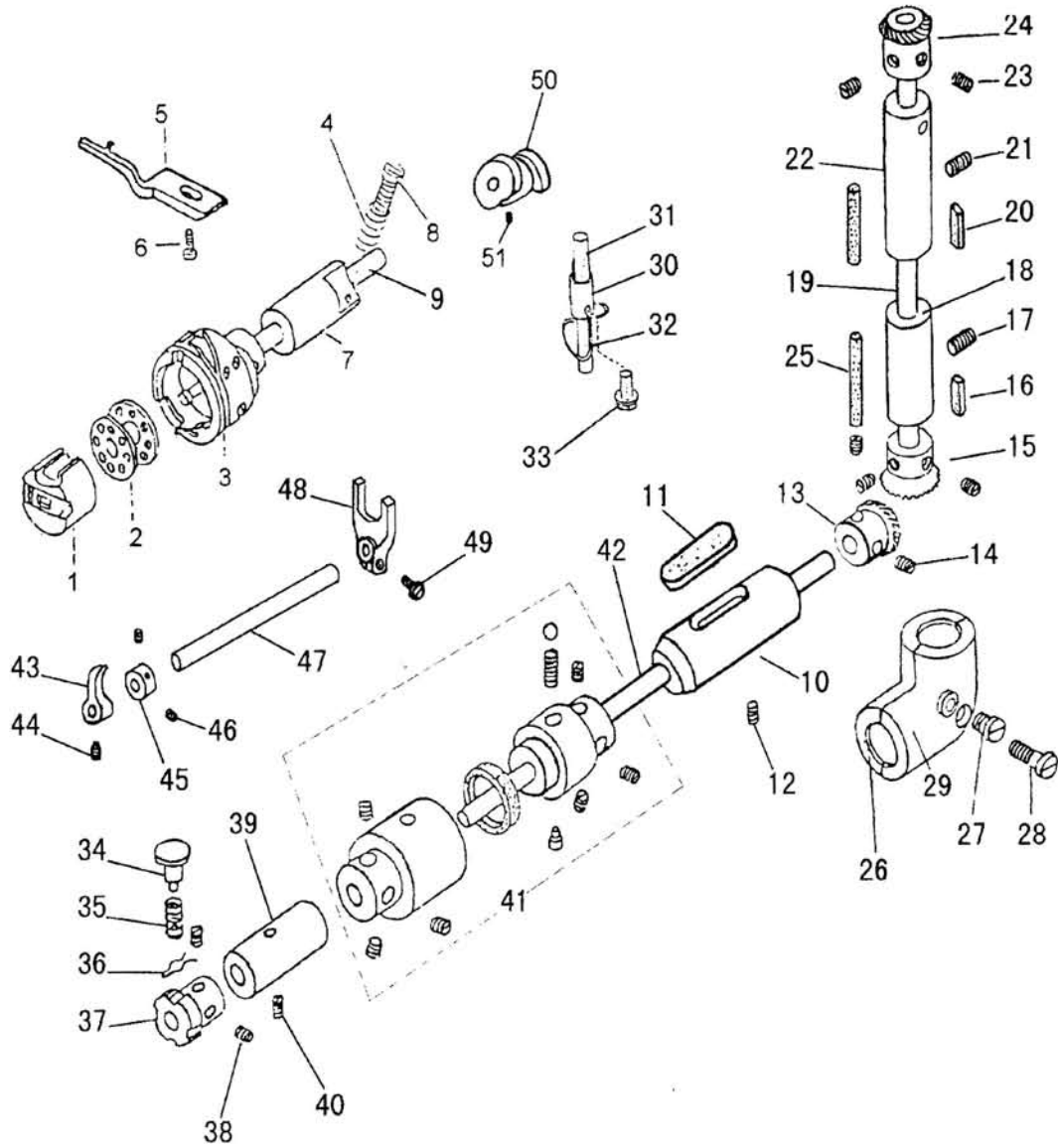

## C.ROTATING HOOK SHAFT MECHANISM

Fig. No.	Part No.	Description	618-1-D2	Remarks
C01	HA900E2030	Bobbin case complete	1	
C02	HA600E2060	Bobbin	1	
C03	H2200C2050	Rotating hook complete	1	
C04	H2000M0070	Spring for oil adjusting screw	1	
C05	H4200D2010	Rotating hook positioner	1	
C06	HA100E2150	Screw	1	SM11/64(40)×10
C07	H2009B0772	Hook shaft bushing(left)	1	
C08	H2000M0060	Oil adjusting screw	1	
C09	H2200C2030	Rotating hook shaft	1	
C10	H2009B0751	Hook shaft bushing(right)	1	
C11	H2009B0711	Felt	1	
C12	H2000I2080	Screw	1	SM11/64(40)×8.5
C13	HA113D2212	Bevel gear for hook shaft	1	
C14	HA108C0663	Set screw	4	SM1/4 (40) ×7
C15	HA113D2222	Bevel gear for vertical shaft(lower)	1	
C16	H2009B0711	Felt	1	
C17	HA100C2020	Screw	1	SM15/64(28)×10
C18	H2009B0721	Vertical shaft bushing(lower)	1	
C19	H3104D0651	Vertical shaft	1	
C20	H2009B0711	Felt	1	
C21	HA100C2020	Screw	1	SM15/64(28)×10
C22	H31196B104	Vertical shaft bushing(up)	1	
C23	HA108C0663	Set screw	2	SM1/4 (40) ×7
C24	HA113D2122	Bevel gear for vertical shaft(up)	1	
C25	H2009B0712	Oil wick	2	
C26	H2018M0066	Bevel gear cover(lower-backward)	1	
C27	HA300B2110	Rubber plug	2	
C28	H409050140	Screw	1	M5×14
C29	H2018M0065	Bevel gear cover(lower-forward)	1	
C30	H2008M0065	Oil pipe	1	
C31	H2008M0066	Felt	1	
C32	H2008M0067	Oiling felt spring	1	
C33	HA300B2170	Screw	1	SM11/64(40)×9

### C.ROTATING HOOK SHAFT MECHANISM

Fig. No.	Part No.	Description			618-1-D2		Remarks
C39	HA704B0653	Hook shaft bushing(middle)			1		
C50	HA810E0691	Thread trimming eccentric			1		
C51	HA810E0692	Screw			2		

# D.STITCH REGULATOR MECHANISM

---

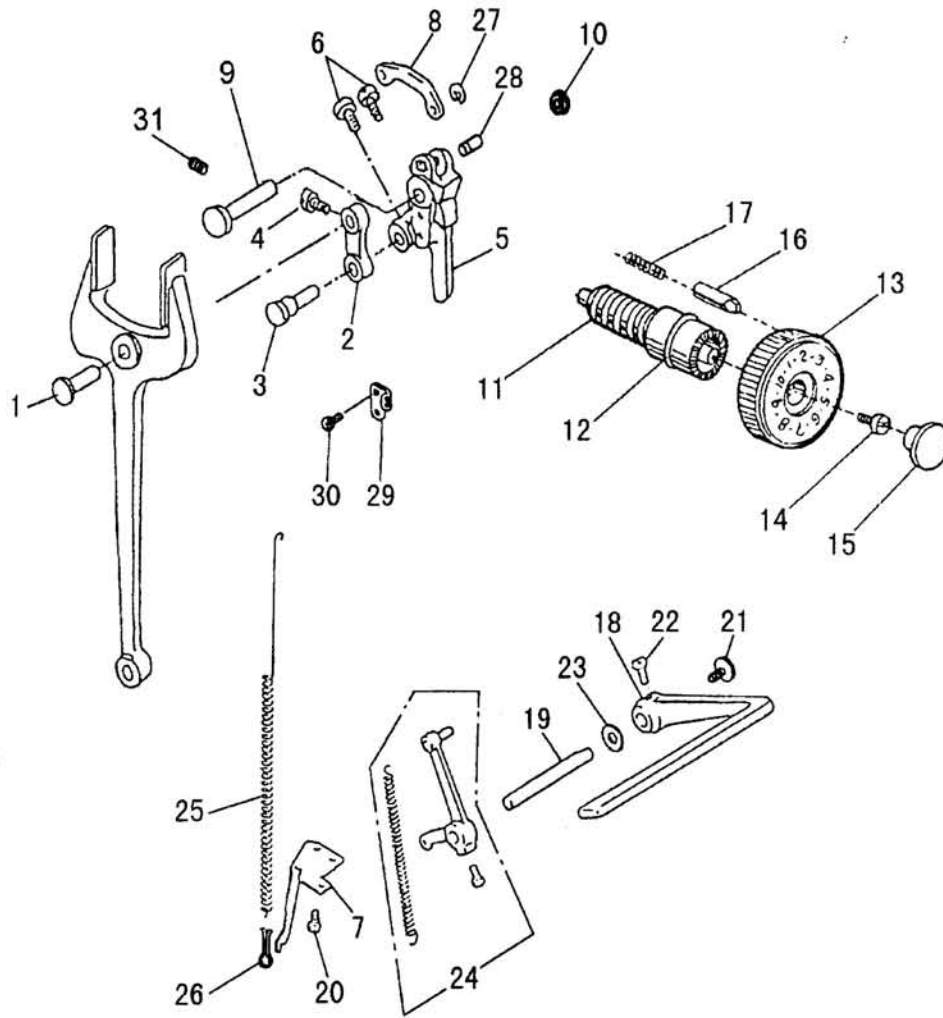

## D.STITCH REGULATOR MECHANISM

Fig. No.	Part No.	Description			618-1-D2	Remarks
D01	HA104F0651	Hinge pin			1	
D02	HA104F0652	Feed connecting link			1	
D03	H3100E2170	Feed connecting link hinge pin			1	
D04	HA104F0654	Screw			1	SM15/64 (28) ×10
D05	H42111E104	Feed regulator cam			1	
D06	HA104F0654	Screw			2	SM15/64 (28) ×10
D07	H2200D2030	Spring retainer			1	
D08	H2204D0651	Reverse link			1	
D09	H3100E2230	Hinge pin for feed regulator			1	
D10	HA700B2120	Rubber plug			1	
D11	HA109F0671	Feed regulator screw bar			1	
D12	HA109F0674	O-ring			1	
D13	H1104F0651	Dial			1	
D14	HA109F0673	Screw			1	SM3/16 (28) ×8
D15	HA100F2070	Rubber plug			1	
D16	HA100F2080	Stopper pin			1	
D17	HA100F2090	Spring for stopper pin			1	
D18	HA309F0671	Reverse feed lever			1	
D19	H2005F0065	Reverse feed lever pin			1	
D20	HA300C2030	Screw			2	SM11/64(40)×8
D21	HA113F0683	Screw			1	
D22	HA104F0654	Screw			2	SM15/64 (28) ×10
D23	HA100F2110	Washer			1	
D24	H4205E0066	Reverse feed lever crank complete			1	
D25	H2204D0654	Spring			1	
D26	HA806C0675	Spring retainer			1	
D27	H007013040	Stop ring			1	
D28	H2204D0652	Pin			1	
D29	H2204D0653	Spring retainer			1	
D30	HA100C2190	Screw			2	SM11/64(40)×8
D31	H2405D0664	Screw			1	

# E.LOWER FEEDING MECHANISM

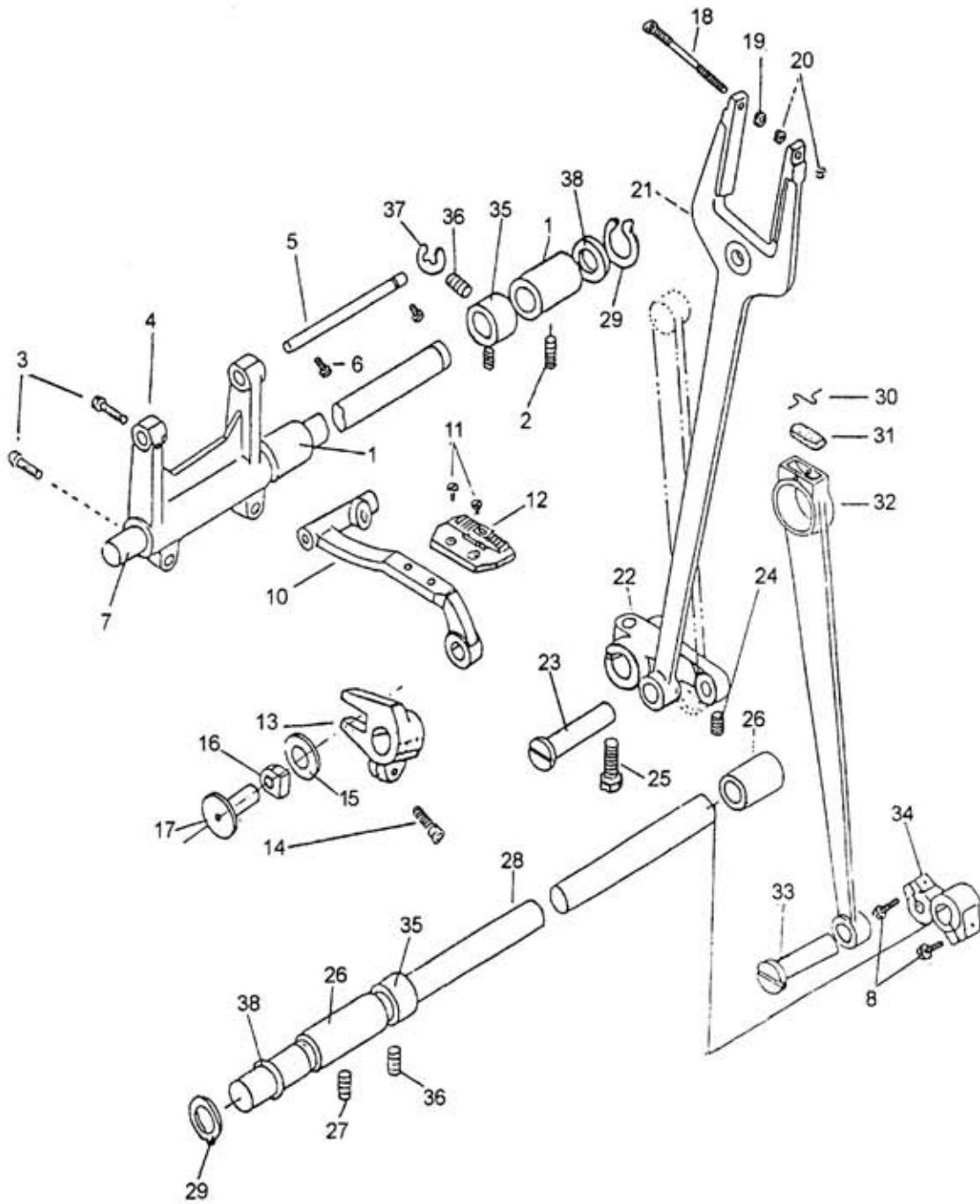

## E.LOWER FEEDING MECHANISM

Fig. No.	Part No.	Description	618-1-D2	Remarks
E01	H2009B0069	Feed rock shaft bushing	2	
E02	HA100C2020	Set screw	2	SM15/64(28)×10
E03	HA304G0656	Screw	2	
E04	H3100E2110	Feed rock shaft crank	1	
E05	H3100E2120	Feed bar shaft	1	
E06	HA100C2020	Screw	2	SM15/64(28)×10
E07	H2005L0065	Feed rock shaft	1	
E08	HA104G0012	Screw	2	
E10	H3116E0661	Feed bar	1	
E11	HA104G0654	Screw	2	SM1/8(44)×6
E12	H4206E0671	Feed dog	1	
E13	H3100E2140	Feed lifting rock shaft crank(left)	1	
E14	H415050120	Screw	2	M5×12
E15	H3100E2200	Washer	1	
E16	H3100E2190	Slide block	1	
E17	HA305G1012	Slide block shaft	1	
E18	H3100E2050	Screw	1	
E19	H3100E2180	Nut 1	1	M4
E20	H3100E2190	Nut 2	2	M3
E21	H3100E2040	Feed forked connection	1	
E22	H3100E2090	Feed rock shaft crank	1	
E23	HA100G2070	Feed rock shaft crank hinge pin	1	
E24	HA104F0654	Screw	3	SM15/64 (28) ×10
E25	H3100E2100	Screw	1	
E26	H2009B0069	Feed lifting rock shaft bushing	2	
E27	HA100C2020	Screw	2	SM15/64(28)×10
E28	H2004K0065	Feed lifting rock shaft	1	
E29	H007009150	Stop ring	2	
E30	H20111C106	Oiling felt spring	1	
E31	H20111C206	Felt	1	
E32	H3100E2030	Feed lifting link	1	
E33	HA100G2070	Feed rock shaft crank hinge pin	1	
E34	HA306G0671	Feed lifting rock shaft crank(right)	1	
E35	HA108G0661	Feed rock shaft collar	2	
E36	HA105D0662	Set screw	4	SM1/4(40)×4
E37	H007013050	Stop ring	1	
E38	HA100G2130	Washer	2	



# F.NEEDLE BAR FEEDING MECHANISM

---

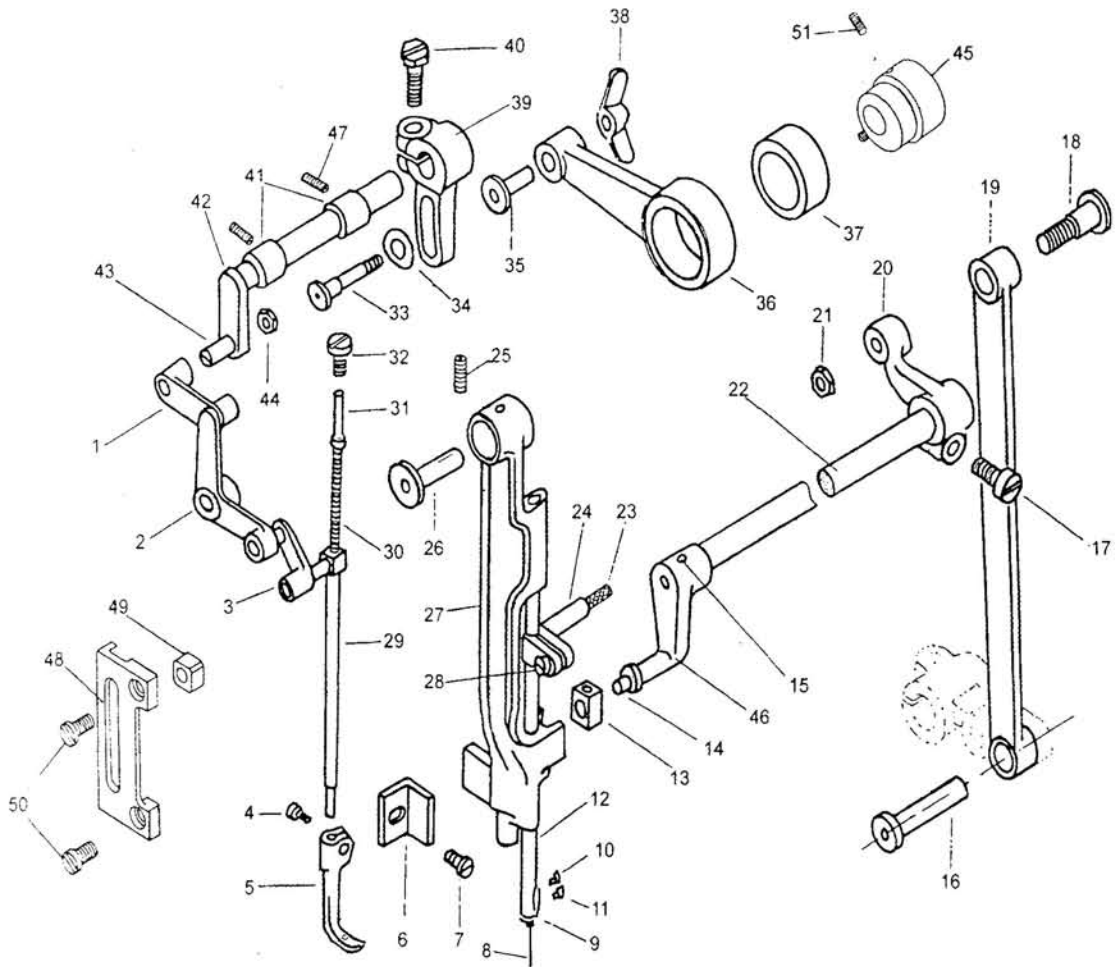

## F.NEEDLE BAR FEEDING MECHANISM

Fig. No.	Part No.	Description	618-1-D2	Remarks
F01	H3100F2010	Crank link	1	
F02	H3100F2020	Lifting bell crank	1	
F03	H3100F2030	Link	1	
F04	HA700F2100	Screw	1	
F05	H3111F0651	Vibrating presser foot	1	
F06	H3100F2240	Needle bar rack frame position bracket	1	
F07	H3400C2020	Screw	1	
F08	H2000G2030	Needle	1	DP×17 22#
F09	H3129F0693	Needle bar thread guide	1	
F10	H3129F0691	Screw	1	SM3/32(56)×2.5
F11	HA100C2170	Screw	1	SM1/8 (44) ×4.5
F12	H3129F0692	Needle bar	1	
F13	H3100F2270	Needle bar rock frame slide block	1	
F14	H3406C0671	Needle bar rock frame slide block stud	1	
F15	H602040240	Set screw	1	
F16	HA100G2070	Hinge pin	1	
F17	H3132F0712	Screw	1	
F18	H3100F2310	Screw	1	
F19	H3100F2300	Needle bar rock frame rock shaft crank connect	1	
F20	H3132F0711	Needle bar rock frame rock shaft crank (right)	1	
F21	H2010J0066	Nut	1	
F22	H3131F0703	Needle bar rock frame rock shaft	1	
F23	H3126F0683	Oil wick	1	
F24	H4200F2010	Needle bar adaptor	1	
F25	HA100C2020	Screw	1	SM15/64(28)×10
F26	H3100F2200	Needle bar rock frame hinge stud	1	
F27	H3100F2220	Needle bar rock frame	1	
F28	HA7311CD06	Screw	1	
F29	H3100F2070	Vibrating presser bar	1	
F30	H3100F2060	Vibrating presser bar extension spring	1	
F31	H3100F2050	Vibrating presser bar extension	1	
F32	H3100F2040	Screw	1	
F33	H3100F2130	Screw	1	
F34	H005001060	Washer	1	
F35	H3100F2150	Lifting eccentric connecting collar	1	
F36	H3100F2170	Lifting eccentric connection	1	
F37	H3100F2180	Needle bearing for lifting eccentric connection	1	
F38	H3100F2160	Nut	1	
F39	H3115F0672	Lifting eccentric connecting crank	1	
F40	H3115F0671	Screw	1	

## F.NEEDLE BAR FEEDING MECHANISM

Fig. No.	Part No.	Description	618-1-D2	Remarks
F41	H3100F2100	Lifting rock shaft bushing	2	
F42	H3112F0663	Lifting rock shaft	1	
F43	H3112F0661	Screw	1	
F44	H3112F0662	Nut	1	
F45	H3100F2330	Lifting eccentric	1	
F46	H3131F0704	Needle bar rock frame rock shaft crank(left)	1	
F47	HA100B2110	Set screw	2	SM11/64(40)×5.5
F48	H3100F2340	Guide for slide block	1	
F49	H3100F2350	Slide block	1	
F50	H3100F2360	Screw	2	SM9/64(40)×7
F51	HA105D0662	Screw	2	
F52	HA7311C306	Screw	2	
F53	H3100F2370	Stop plate	1	
F54	H3200I2030	Washer	1	

# G.PRESSER FOOT MECHANISM

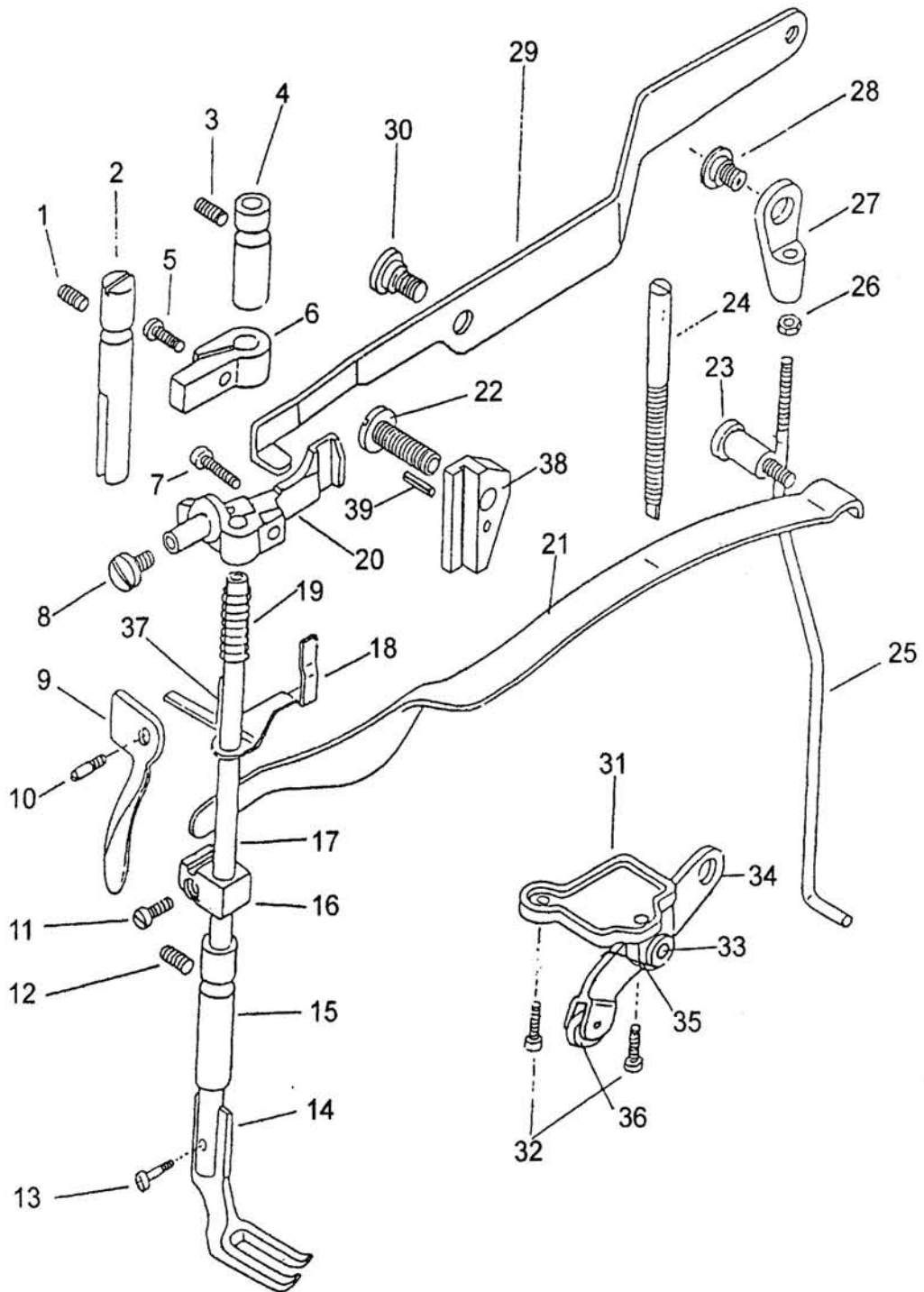

## G.PRESSER FOOT MECHANISM

Fig. No.	Part No.	Description			618-1-D2	Remarks
G01	HA3411D308	Set screw			1	
G02	H3100G2020	Presser bar position guide			1	
G03	HA100C2020	Set screw			1	
G04	H3104B0654	Presser bar bushing(upper)			1	
G05	H2404I0034	Screw			1	
G06	H3106G0652	Presser bar position guide bracket			1	
G07	H3107G0661	Screw			1	
G08	H3107G0662	Screw			1	
G09	H3100G2070	Presser bar lifter			1	
G10	H3100G2080	Screw			1	
G11	H2404I0034	Screw			1	
G12	HA100C2020	Screw			1	
G13	H3100G2120	Screw			1	SM9/64(40)×6
G14	H3100G2110	Lifting presser foot			1	
G15	H3104B0656	Presser bushing(lower)			1	
G16	H3113G0671	Presser bar spring bracket			1	
G17	H3100G2090	Presser bar			1	
G18	H3109G0651	Tension release slide			1	
G19	H3100G2050	Tension release spring			1	
G20	H3107G0663	Presser bar lifting bracket			1	
G21	H3100G2150	Presser bar spring			1	
G22	H3100G2220	Screw			1	SM1/4(24)×20
G23	H3100G2170	Screw			1	
G24	H3100G2160	Screw			1	
G25	H3100G2240	Knee lifter lifting lever connecting rod			1	
G26	H2000I2160	Nut			1	
G27	H2000I2150	Knee lifter lifting lever connecting rod joint			1	
G28	H2000I2140	Screw			1	
G29	H3100G2140	Knee lifter lifting lever			1	
G30	H3100G2130	Screw			1	
G31	H3128G0651	Knee lifter bell crank base			1	
G32	H2000I2200	Screw			1	
G33	H604050180	Pin			1	
G34	H3128G0652	Knee lifter bell crank			1	
G35	H2000I2190	Spring for knee lifter bell crank			1	
G36	H2021I0068	Roller			1	
G37	H3109G0652	Guide for tension release slide			1	
G38	H4206C8001	Presser bar lifting bracket guide			1	
G39	H609025180	Spring pin			1	

# H.KNIFE MECHANISM

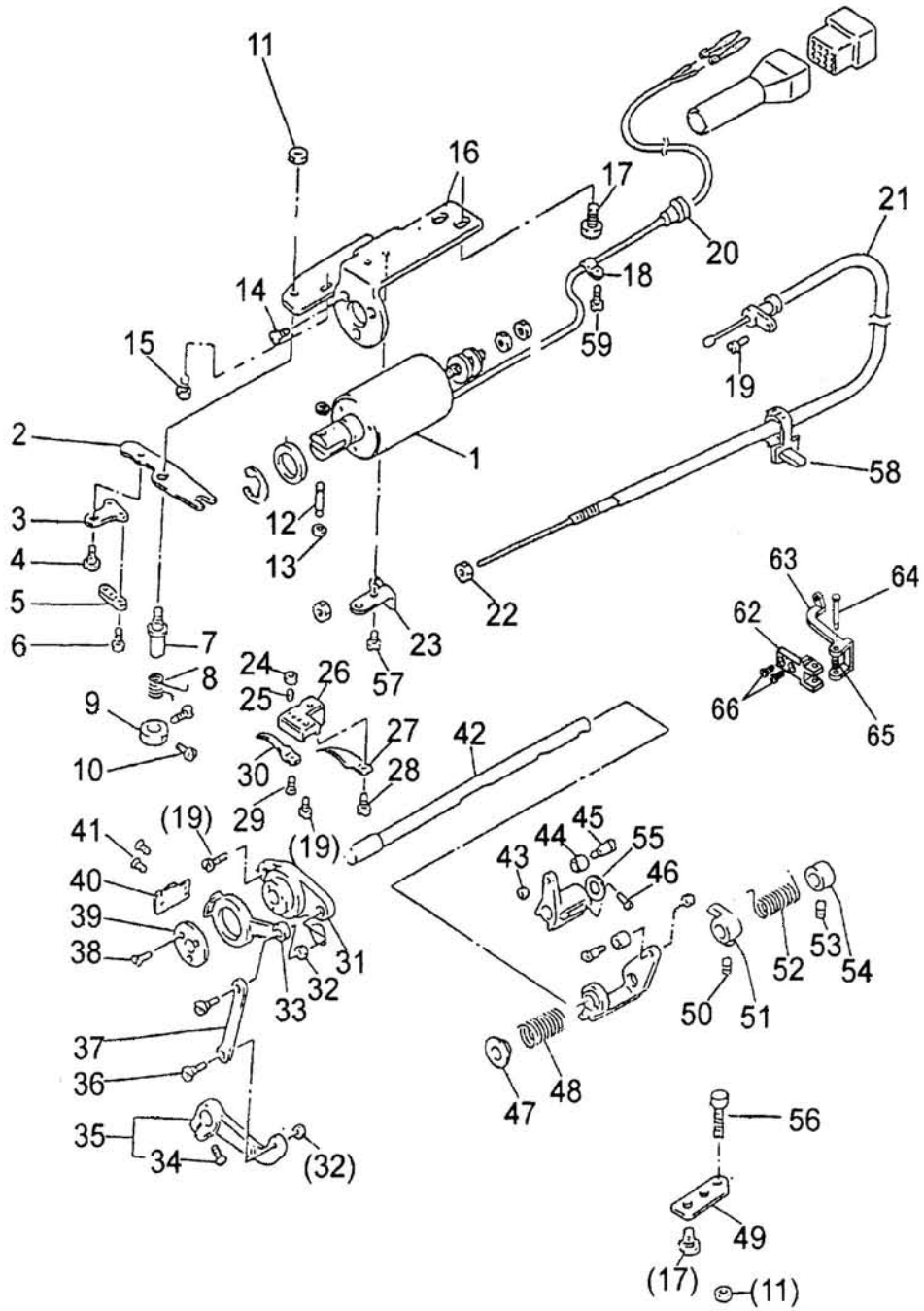

## H.KNIFE MECHANISM

Fig. No.	Part No.	Description	618-1	618-1-SC	618-1-D2	518-1	Remarks
H01	HA7511N112	Solenoid			1		
H02	HA712N0698	Thread trimmer driving lever			1		
H03	HA712N6910	Flexible wire presser			1		
H04	HA712N0699	Screw			1		SM11/64(40)×4
H05	HA712N6911	Flexible wire presser			1		
H06	HA712N6912	Screw			2		SM1/8(44)×7
H07	HA712N0695	Stud screw			1		
H08	HA712N0697	Spring			1		
H09	HA712N0696	Collar			1		
H10	HA7311CC06	Screw			2		
H11	HA710N0683	Nut			1		
H12	HA712N0692	Link stud			1		
H13	H007013040	Washer			2		
H14	HS90011406	Screw			3		M4×6
H15	HA100E2150	Screw			1		SM11/64(40)×10
H16	HA7511N212	Solenoid bracket			1		
H17	HA700N0080	Screw			4		SM15/64(28)×12
H18	HA708P0668	Cord holder			4		
H19	HA300B2170	Screw			1		
H20	HA704O0657	Rubber plug			1		
H21	HA713N0070	Flexible wire complete			1		
H22	H003002050	Nut			2		M5
H23	H2208H0681	Flexible wire base			1		
H24	HA7121N704	Nut			2		SM9/64(40)
H25	HA7121N604	Screw			1		SM9/64(40)×8.5
H26	HA7121N104	Bracket for fixed blade			1		
H27	H22121H204	Thread finger			1		
H28	HA7311CH06	Screw			1		SM9/64(40)×8
H29	HA7121N304	Screw			1		SM9/64(40)×5
H30	H4204H1111	Fixed blade			1		
H31	HA704N1111	Knife holding bracket saddle			1		
H32	HA7111N304	Nut			2		SM11/64(40)
H33	HA904N1111	Knife holding bracket saddle(left)			1		
H34	HA719B7011	Screw			1		SM11/64(40)×11.4
H35	HA7111N604	Knife driving crank			1		
H36	HA7111N204	Screw			2		SM11/64(40)×6.2
H37	HA7111N404	Link			1		
H38	HA704N1114	Screw			3		SM1/8(44)×5.2
H39	HA704N1113	Washer			1		
H40	H2204H0651	Fixed blade			1		
H41	HA7111N704	Screw			2		SM11/64(40)×5.5
H42	H2200H2020	Driving crank shaft			1		
H43	HA706N0663	Nut			2		

## H.KNIFE MECHANISM

Fig No.	Part No.	Description	618-1	618-1-SC	618-1-D2	518-1	Remarks
H44	HA7221N106	Roller			2		
H45	HA7221N206	Roller pin			2		
H46	HA113F0684	Screw			2		SM15/64(28)×8.5
H47	HA700N0050	Spring cover			1		
H48	HA700N0040	Spring			1		
H49	HA710N0682	Lever stopper plate			1		
H50	HA307C0662	Screw			1		
H51	H2206H0661	Stopper lever			1		
H52	HA700N0110	Coil spring			1		
H53	HA715N0711	Collar			1		
H54	HA105D0662	Screw			1		
H55	HA706N0664	Washer			1		
H56	H2207H0671	Screw			1		
H57	HA300C2030	Screw			2		
H58	HA300I2040	Wire holder			1		
H59	HA300B2170	Screw			2		
H60	HA7211N106	Crank 1			1		
H61	HA7211N206	Crank 2			1		
H62	H4205C0661	Hinge pin bracket			1		
H63	H4205C0662	Hinge pin			1		
H64	H4205C0663	Pin			1		
H65	H4205C0664	Spring			1		
H66	HA104G0654	Screw			2		



# I.TOUCH BACK AND DETECTOR MECHANISM

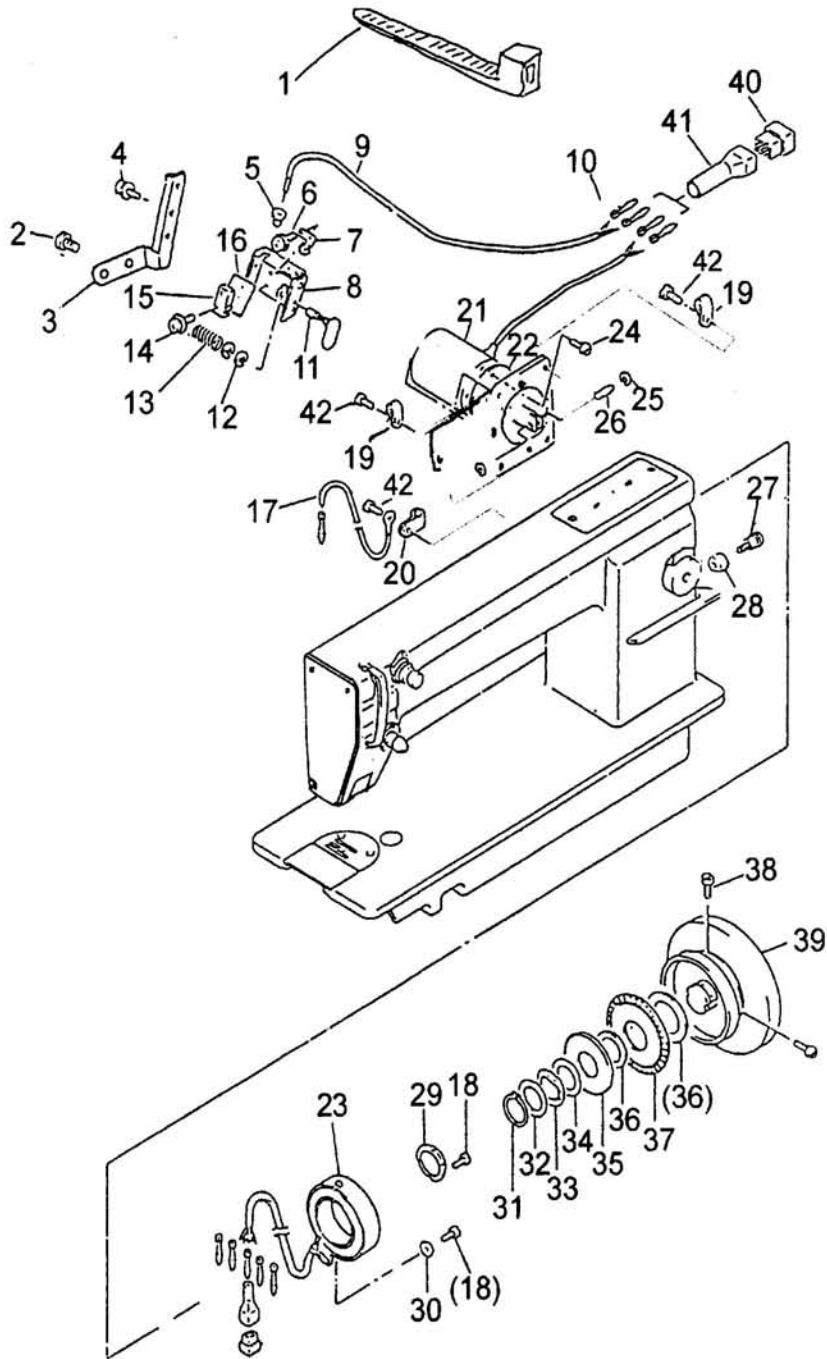

# I.TOUCH BACK AND DETECTOR MECHANISM

Fig. No.	Part No.	Description			618-1-D2	Remarks
I01	HA300I2040	Wire holder			1	
I02	HA300B2170	Screw			2	
I03	H4204I0651	Switch bracket			1	
I04	H411030060	Screw			2	
I05	HA704O0657	Rubber plug			1	
I06	HA704O0659	Screw			2	
I07	HA704O0654	Plate spring			1	
I08	H2205I0661	Switch bracket			1	
I09	HA7161O104	Switch wire			1	
I10	HA7641B319	Tie-in			2	
I11	HA704O0021	Touch switch complete			1	
I12	H007013030	Stop ring			2	
I13	HA704O0653	Spring			1	
I14	HA704O6510	Screw			2	
I15	HA704O0655	Micro switch			1	
I16	HA704O0658	Insulator seat			1	
I17	HA705Q0065	Ground wire assy.			1	
I18	HA300C2030	Screw			2	
I19	HA708P0668	Cord holder			4	
I20	HA700Q0050	Cord holder			1	
I21	H2206I0673	Solenoid			1	
I22	H2609E0674	Washer			1	
I23	HA703R0065	Detector complete			1	
I24	HA300C2030	Screw			4	
I25	H007013040	Washer			2	
I26	HA712N0692	Link stud			1	
I27	H2204G0651	Screw			1	
I28	H2204G0652	Stop ring			1	
I29	HA703R0066	Detector bracket supporter			1	
I30	HA703R0067	Washer			1	
I31	H007009300	Stop ring			1	
I32	HA700R0060	Washer			1	
I33	HA700R0050	Supporter spring			1	
I34	HA700R0040	Spacer 2			1	
I35	HA700R0020	Speed command disc 2			1	
I36	HA700R0030	Spacer 1			2	
I37	HA700R0010	Speed command disc 1			1	
I38	HA110I0672	Screw			2	SM15/64(28)×12
I39	H2204I0651	Balance wheel			1	
I40	HA700Q0010	Pin			1	
I41	HA7641B319	Tie-in			1	
I42	HA300B2160	Screw			3	SM11/64(40)×10

# J.ACCESSORIES

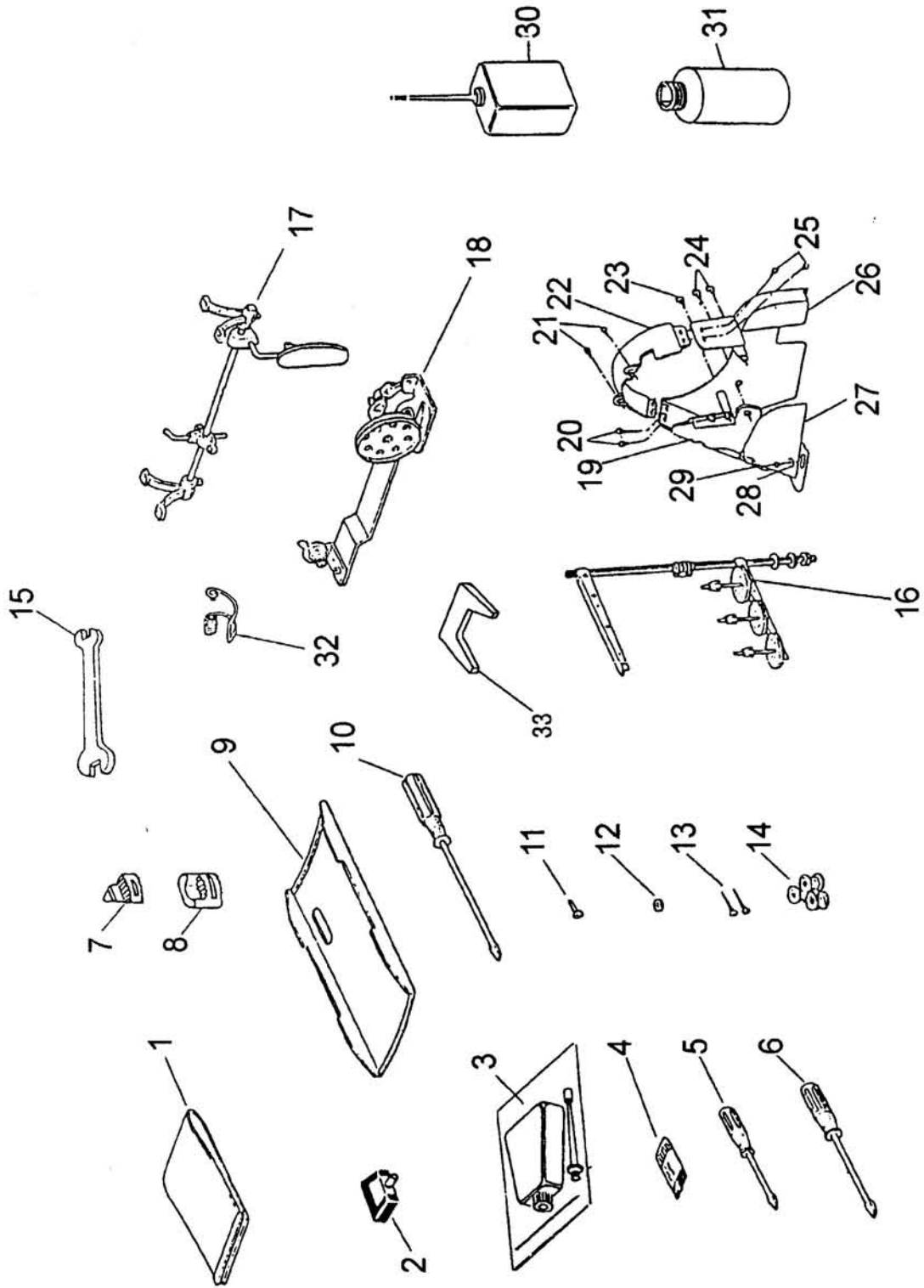

## J.ACCESSORIES

Fig. No.	Part No.	Description	618-1-D2	Remarks
J01	HA300J2180	Vinyl cover	1	
J02	HA307J0067	Bed hinge connection	2	
J03	H2004O0069	Oiler	1	
J04	H2000G2030	Needle	1	DP×17 22#
J05	HA300J2210	Screw driver(small)	1	
J06	HA300J2200	Screw driver(middle)	1	
J07	H2004O0066	Rubber cushion(small)	2	
J08	H2004O0065	Rubber cushion(large)	2	
J09	H2207J0065	Oil pan assy.	1	
J10	HA300J2070	Screw driver(large)	1	
J11	H801045200	Screw	2	4.5×20
J12	HA300J2230	Washer	2	
J13		Nail	10	
J14	HA600E2060	Bobbin	3	
J15	HA100J2170	Spanner	1	
J16	HA200J2030	Thread stand	1	BZ009
J17	H3104H0065	Knee lifter assy.	1	
J18	HA905S0066	Bobbin winder mechanism	1	
J19	H2008O0070	Belt cover	1	
J20	HA300B2170	Set screw	2	SM11/64(40)×8
J21	HA300B2170	Set screw	2	SM11/64(40)×8
J22	H2008O0671	Belt cover with label	1	
J23	HA300J2250	Screw	1	M4×12.5
J24	HA300J2280	Screw	2	
J25	HA300B2170	Screw	2	
J26	H2008O0067	Belt cover(lower)	1	
J27	HA305J0665	Belt cover assy.	1	
J28	HA300J2230	Washer	2	
J29	H801045200	Screw	2	4.5×20
J30	H2004O0069	Oiler	1	
J31	HA600J2030	Oiler	1	
J32	H3111B0702	Thread tension spring	1	
J33	HA704S0654	Speed command disc adjusting plate	1	