

# ARTISAN.®

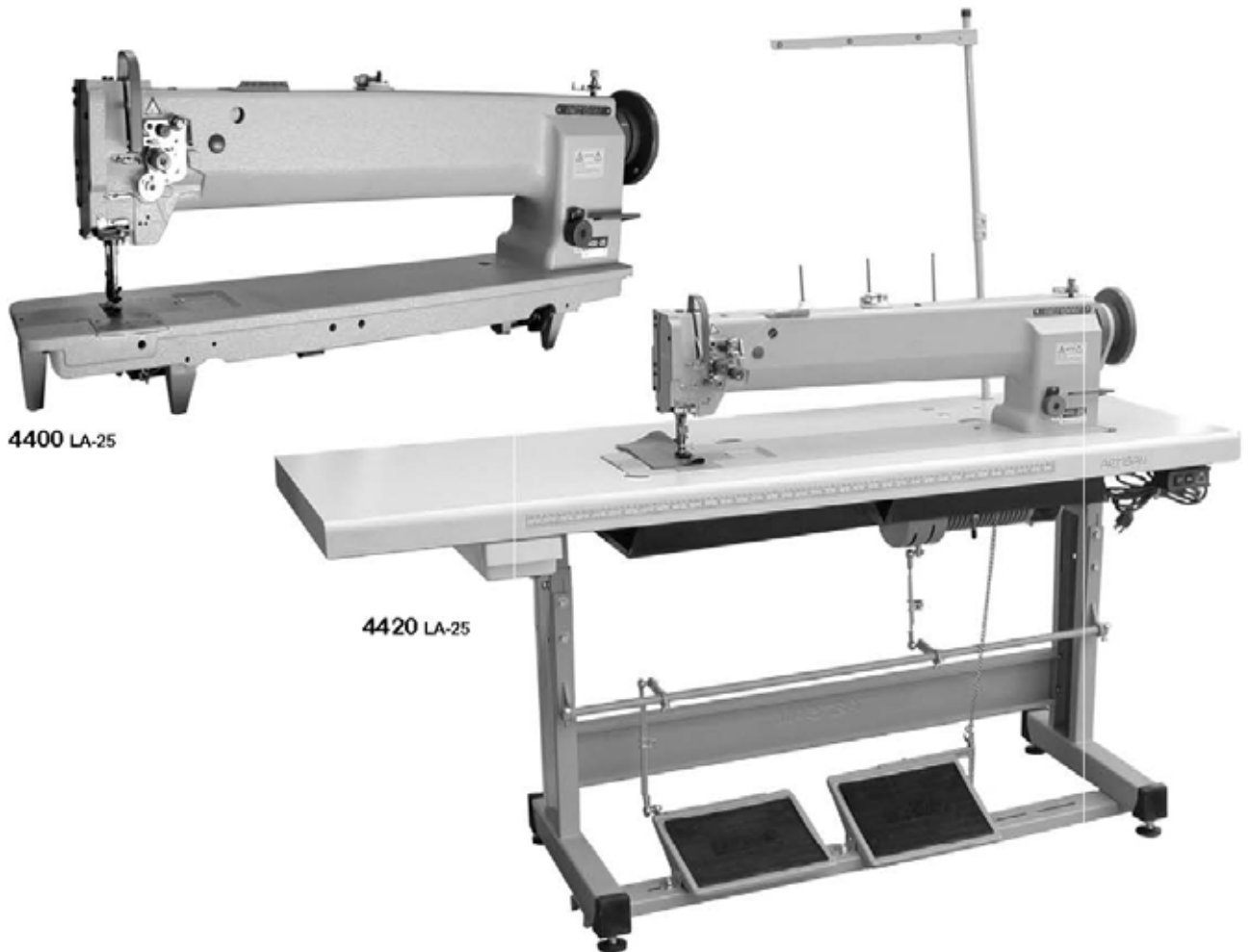

4400 LA-25

4420 LA-25

## ARTISAN.

### 4400 LA-25 and 4420 LA-25

25" Long Arm, Single Needle and Double Needle Lockstitch  
Compound Needle Feed, Walking Foot Sewing Machines

**OPERATORS MANUAL**  
and  
**SPARE PARTS BOOKLET**

---

## CONTENTS

<b>PRECAUTIONS BEFORE STARTING OPERATION</b> .....	1
<b>PREPARATION FOR OPERATION</b>	
1. Power cable connection .....	2
2. Connection of control box .....	3
3. Adjustment of needle bar stop position .....	3
<b>CAUTIONS ON USE</b>	
1. Oiling (1) .....	4
2. Oiling (2) .....	4
3. Oiling condition .....	4
4. Adjustment of oiling to rotating hook .....	5
5. Cautions on operation .....	5
<b>OPERATION</b>	
1. Installation of needles .....	5
2. Winding of bobbin thread .....	6
3. Selection of thread .....	6
4. Threading of needle threads .....	6
5. Adjustment of feed (stitch) length and stitch reversing (touch-back) .....	7
6. Setting of bobbin .....	7
7. Threading of bobbin threads .....	8
8. Tension adjustment of bobbin threads .....	9
9. Balance of thread tension .....	9
10. Needle thread tension .....	9
11. Adjustment of presser foot pressure .....	9
12. Timing between rotating hook motion and needle motion .....	9
13. Adjustment of feed dog height .....	10
14. Relationship between rotating hook motion and take-up lever motion .....	11
15. Relationship between hook motion and opener motion .....	11
16. Relationship between needle motion and feed dog motion .....	11
17. Safety clutch device .....	12
18. Upper feed adjustment (needle side) .....	13
19. Outside presser foot and inside presser vertical stroke adjustment .....	14
20. Adjustment of forward/backward stitch length .....	14
21. Installation of movable knife .....	14
22. Adjustment of thread trimmer cam .....	15
23. Adjustment of needle threads tension release assembly .....	16
24. Adjustment of scissoring pressure of movable knife and fixed knife .....	16
25. Sharpening of fixed knife .....	17
26. Adjustment for change of needle to needle distance .....	17
<b>SPECIFICATIONS</b> .....	18

---

## PARTS CATALOG

1. Arm bed its accessories -----	19
2. Thread tension regulator mechanism -----	21
3. Arm shaft mechanism -----	24
4. Upper shaft & presser foot mechanism -----	26
5. Needle bar & thread take-up lever mechanism -----	29
6. Stitch regulator mechanism -----	32
7. Lower shaft & feed rock shaft mechanism -----	34
8. Hook saddle mechanism -----	37
9. Knife mechanism ( I ) -----	39
10. Knife mechanism ( II ) -----	41
11. Touch back mechanism & detector mechanism -----	44
12. Accessories -----	46
GAUGE PARTS LIST -----	48

---

---

## **PRECAUTIONS BEFORE STARTING OPERATION**

### **1. Safety precautions**

- 1) When turning the power on, keep your hands and fingers away from the area around/under the needle and the area around the pulley.
- 2) Power must be turned off when the machine is not used, or when the operator leaves his/her seat.
- 3) The power must be turned off before tilting the machine head, installing or removing the "V" belt, adjusting the machine, or when replacing.
- 4) Avoid placing fingers, hairs, bars etc. near the pulley, "V" belt, bobbin winder pulley, or motor when the machine is operation. Injury could result.
- 5) Do not insert fingers into the thread take-up cover, under/round the needle, or pulley when the machine is in operation.
- 6) If a belt cover, finger guard, and/or eye guard are installed, do not operate the machine without these safety devices.

### **2. Precaution before Starting Operation**

- 1) If the machine's oil pan has an oil sump, never operate the machine before filling it.
- 2) If the machine is lubricated by a drop oiler, never operate the machine before lubricating.
- 3) When a new sewing machine is first turned on, verify the rotational direction of the pulley with the power on. (the pulley should rotate counterclockwise when viewed from the pulley.)
- 4) Verify the voltage and (single or three) phase with those given on the motor nameplate.

### **3. Precaution for Operating Conditions**

- 1) Avoid using the machine at abnormally high temperature (35°C or higher) or low temperature (5°C or lower). Otherwise, machine failure may result.
- 2) Avoid using the machine in dusty conditions.
- 3) Avoid using the machine in areas where too much electrical noise, resulted from the high-frequency welder and others, is generated.

## PREPARATION FOR OPERATION

Overall view of assembled sewing machine

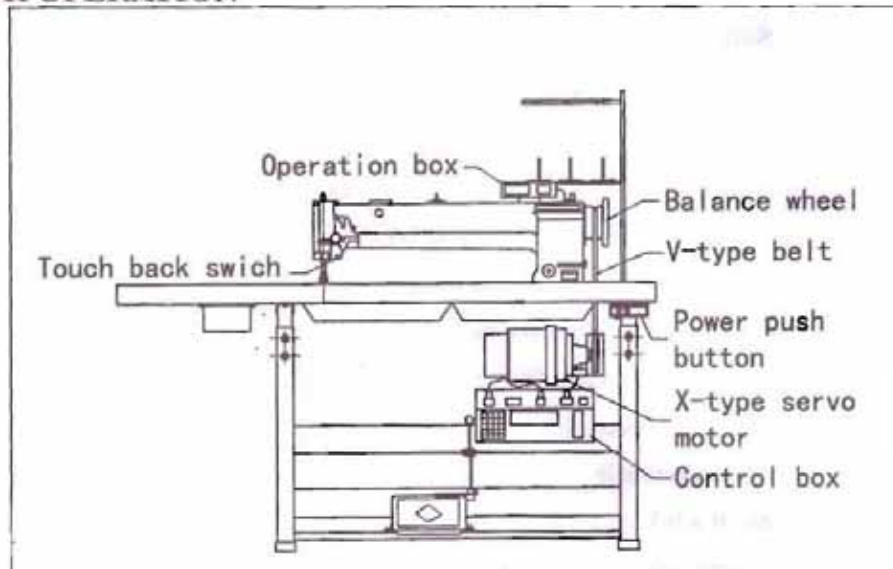

### 1. Power cable connection

#### 1) Connection to Power Supply

When connecting the power supply connector to the control box, the connector should be completely plugged in the proper receptacle after confirming the connector type and matching direction.

- A. In case of three-phase electrical power system, the "U" phase should be connected to the red lead, the "V" phase to the white lead, and the "W" phase to the black lead. The motor rotary direction depends, however, upon the setting of the internal switch in the control box as described in Paragraph 1-(3)

**CAUTION:** The green wire must be connected to the ground terminal in order to ground the motor properly.

- B. The appropriate power fuse capacity is as follows.
- |              |            |     |
|--------------|------------|-----|
| Power supply | 200V-240V: | 10A |
|              | 100V-120V: | 15A |

#### 2) Lamp Leads

- A. When installing the illuminating lamp(6V,15-20W),The connecting wire is attached on the back of the Control box. It should be removed and connected by removing the insulating tube from the wire and stripping properly. The wire connections should be, then, insulated by wrapping insulating tape on the wires.

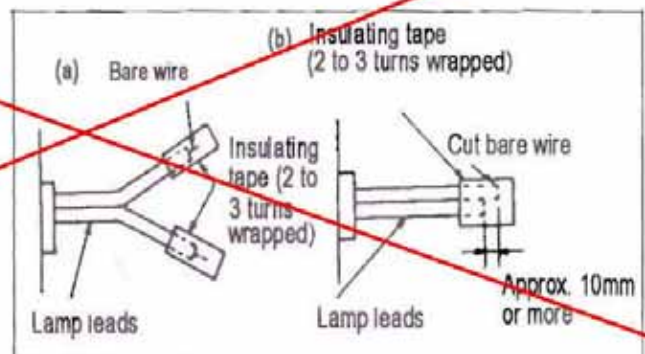

**CAUTION:** The power switch must be Turned off before connecting the lamp.

- B. When the illuminating lamp is not used, the end of the lamp leads must be insulated as (a) or (b) as shown in the figure on right side. If a short circuit occurs failing to insulate, the transformer in the control box will be possibly burned out.

**CAUTION:** The illuminating lamp must not be connected with any heater, such as a foot warmer and others, in parallel. Otherwise, the load capacity will be exceeded. It may cause transformer winding burned out.

### 3) Rotary direction

It is possible to change the rotary direction of the motor by removing the rubber cap from the bottom left side of the front cover on the control box; and push the internal direction selector switch. The built-in lamp in the internal switch is off when the motor is rotating counterclockwise as facing to the motor pulley, and on when rotating clockwise. The rotary direction has been set to counterclockwise as facing to the motor pulley, matching with the machine prior to shipping

## 2. Connection of control box

The control box should be connected as shown to the right.

**Note:** (1) Be sure to turn the power switch off for safety before connecting or disconnecting the connectors.

(2) The combination of the machine heads with the motor control panels are specified below.

Use special care for the correct

combination when replacing the machine head or motor control panel.

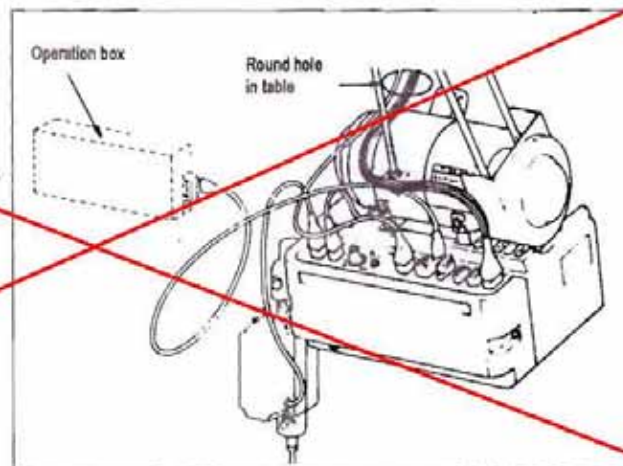

## 3. Adjustment of needle bar stop position

### 1) Adjust of "UP" position

When the pedal is kicked down by heel, the machine stops at "UP" position. If the marks deviate larger than 3 mm, adjust as follows.

- Disconnect the plug (12 pins) of cable from the machine head.
- Run the machine and stop at "UP" position.
- While holding the pulley, insert the "adjusting tool" in the hole "A", then remove the tool.

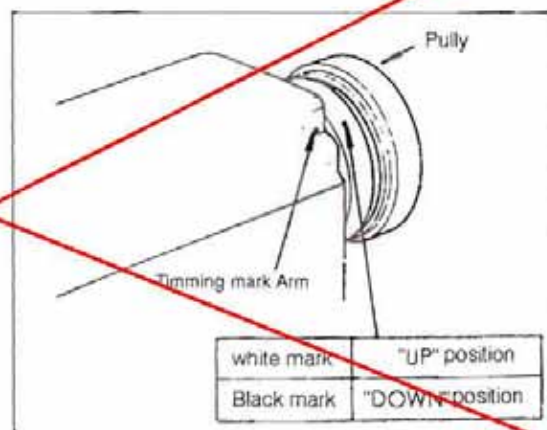

- 2) Adjust of "Down" position  
 When the pedal is "Neutral" the machine stops at "Down" position. If the marks deviate large than 5 mm, adjust as follows

- a) Disconnect the plug (12 pins) of cable from the machine head
  - b) Run the machine and stop at "Down" position
  - c) While holding the pulley, insert the "adjusting tool" in the hole "B", then remove the tool.
- 3) Confirm the stop operation, then set the plug (12 pins) coming from the machine head into the receptacle.

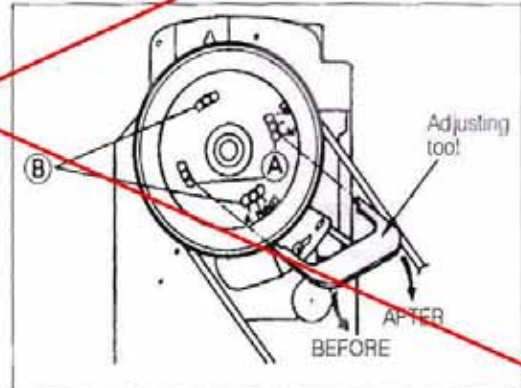

### CAUTIONS ON USE

#### 1. Oiling (1)

Filling the oil to the fount.

Oil level should be periodically checked. If oil level is little, Please replenish oil to enough

**For oil, Use white spindle oil.**

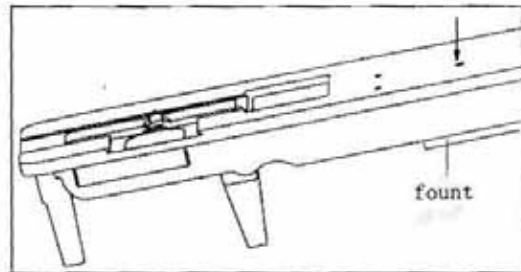

#### 2. Oiling (2)

When a new sewing machine is used for the first time, or sewing machine left out of use for considerably long time is used again, replenish a suitable amount of oil to the portions indicated by arrow in the below figure

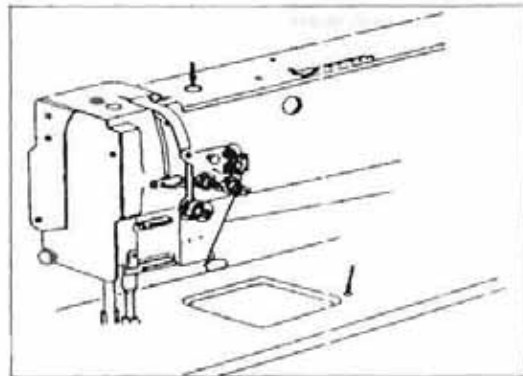
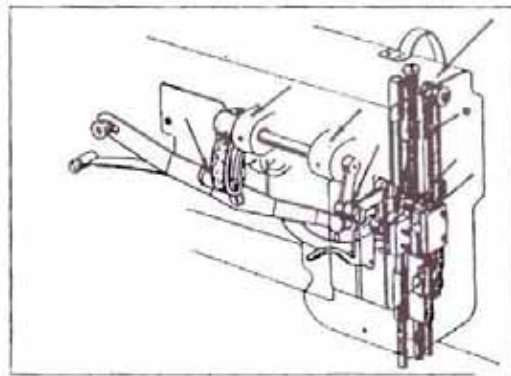

### 3. Oiling condition

See dripping of oil through the oil sight hole to check oiling condition during operation.

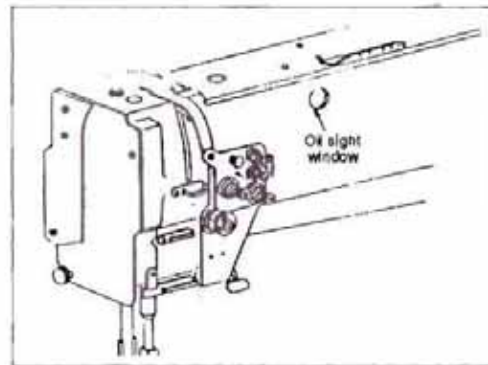

### 4. Adjustment of oiling to rotating hook

### 5. Cautions on operation

- When the power is turned on or off, keep foot away from the pedal.
- It should be noted that the brake may not work when the power is interrupted or power failure occurs during sewing machine operation.
- Since dust in the control box might cause malfunction or control troubles, be sure to keep the control box cover close during operation.
- Do not apply a multimeter to the control circuit for checking; otherwise voltage of multimeter might damage semiconductor components in the circuit.

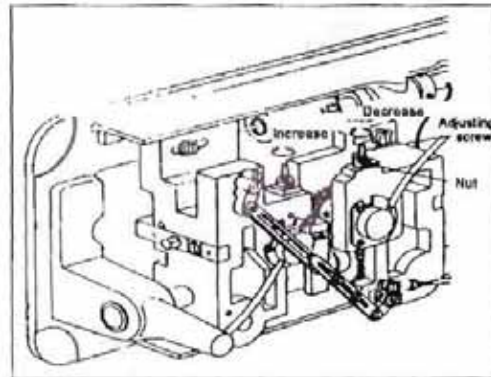

## OPERATION

### 1. Installation of needles

Note: Before installing the needles, be sure to turn off the power.

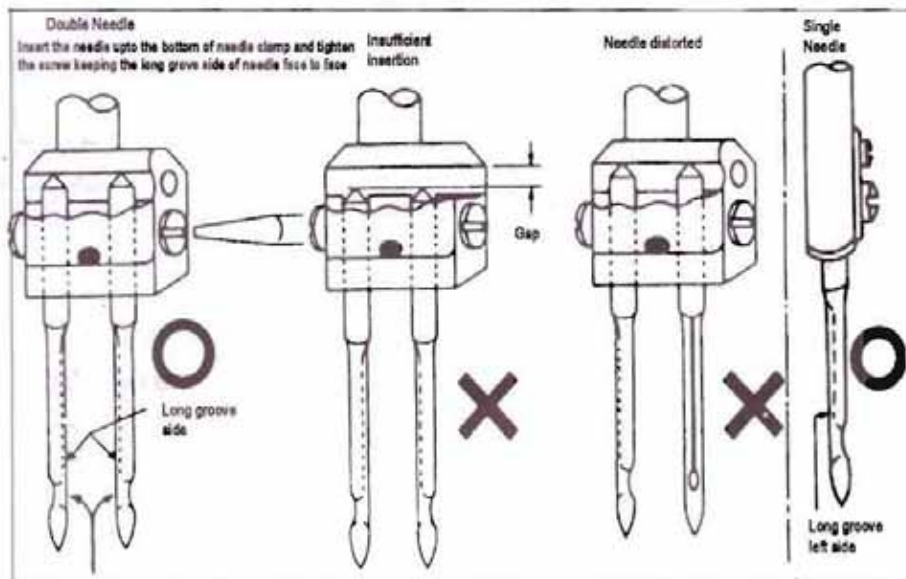



## 2. Winding of bobbin thread

**Note:** When bobbin thread is wound, keep the presser foot lifted.

**Adjustment:**

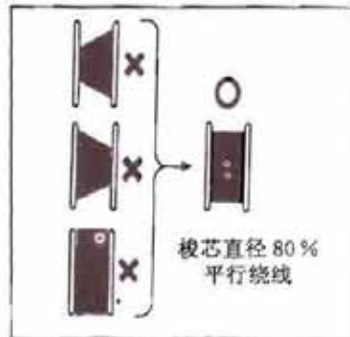

## 3. Selection of thread

It is recommended to use "S" twist thread in the left needle (viewed from front), and "Z" twist thread in the right needle. When discriminate use of needle threads is impossible, use "Z" twist thread in both the needles.

For bobbin thread, "S" twist thread as well as "Z" twist thread can be used.

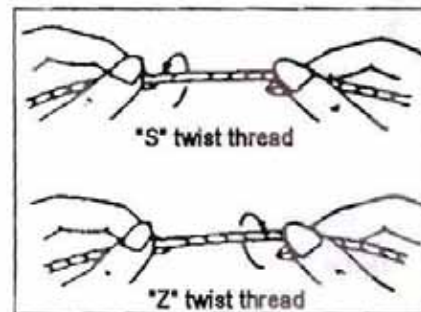

## 4. Threading of needle threads

- a) Pass each needle thread through thread guide A

**Note:** When thin slippery thread (polyester Thread or filament thread, for example) is used pass the thread through thread guide B as well.

- b) With the take-up lever located at the upper most position, pass each needle thread in the order shown in the following figure.

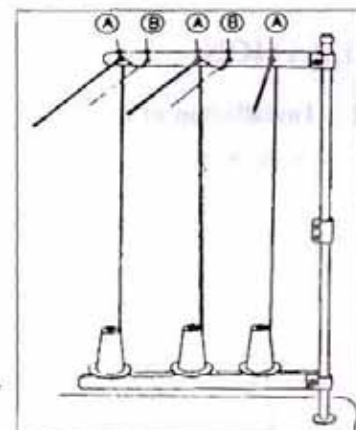

**Note:** Pressing the upper thread loosening button shown in the figure below opens the saucer of the upper thread tension adjuster, and the upper thread can easily pulled out.

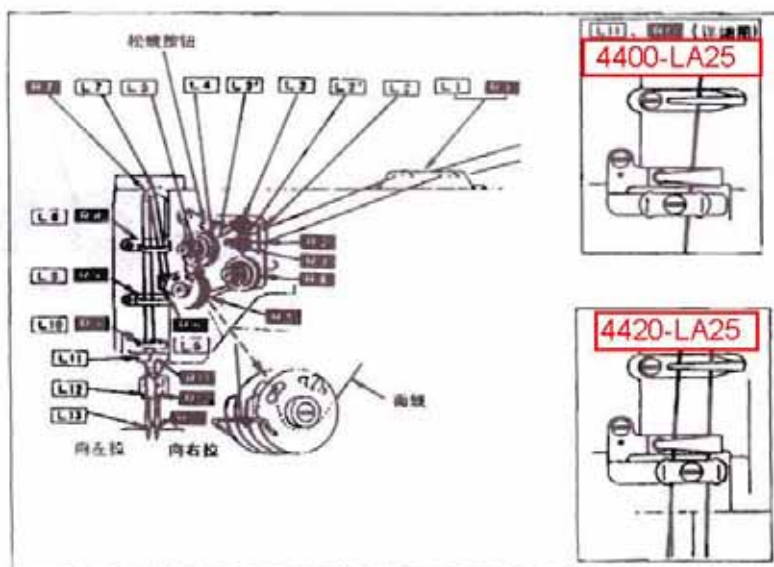

## 5. Adjustment of feed (stitch) length and stitch reversing (touch back)

Note: To make feed (stitch) length smaller, depress the feed reverse lever and set the feed length setting dial to a desired position

Touch-back button . . . Direction of stitching can be reversed by depressing this button.

Stitching goes on in reversed direction while the button is held down, and returns to forward direction when the button is released.

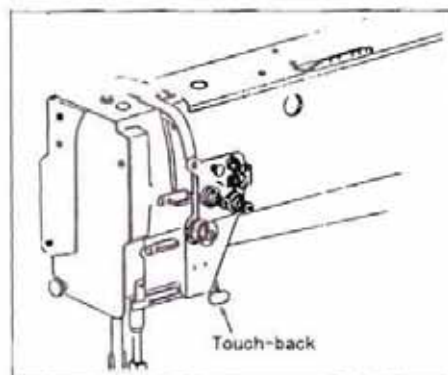
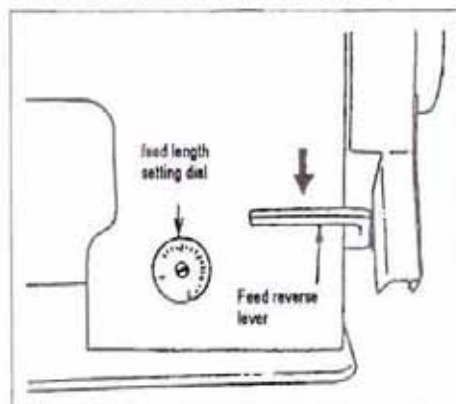

## 6. Setting of bobbin

- Pulling out 5.cm thread tail from the bobbin.
- Hold the bobbin so that the bobbin thread is would in right direction and put it into the hook.

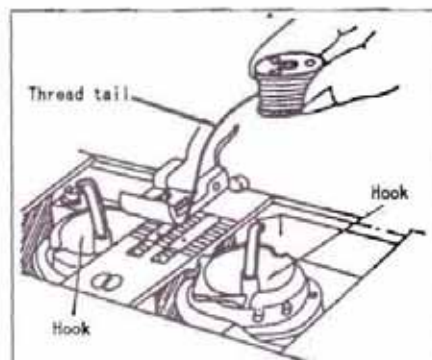

## 7. Threading of bobbin threads

- a) Put the hook into the bobbin case and press down the latch ①. The thread end should be left on the bed.

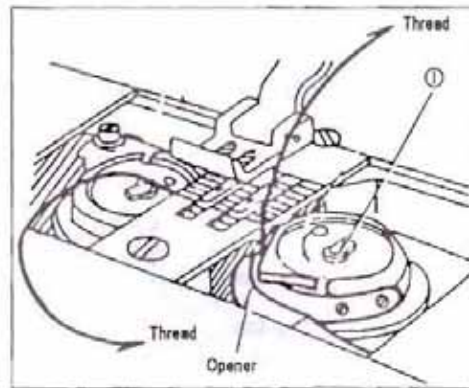

- b) While holding the two needle threads by left hand, rotate the hand-wheel one turn by right hand. By pulling up the needle threads, as shown in the figure, the bobbin threads will be lifted. Each combination of bobbin thread and needle thread should be aligned and led backward.

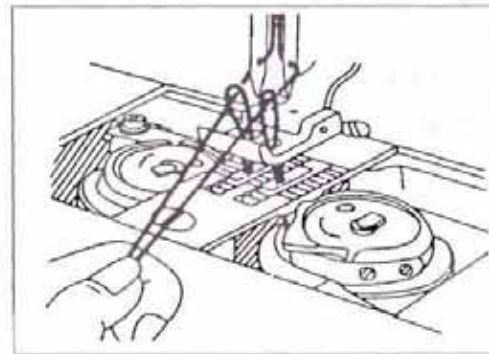

## 8. Tension adjustment of bobbin threads

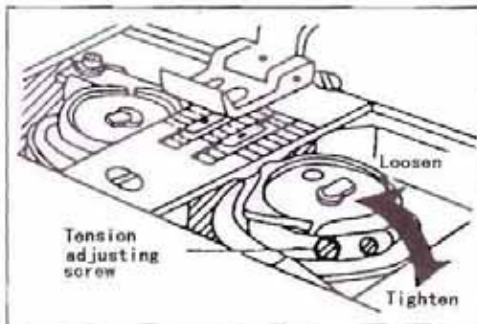

## 9. Balance of thread tension

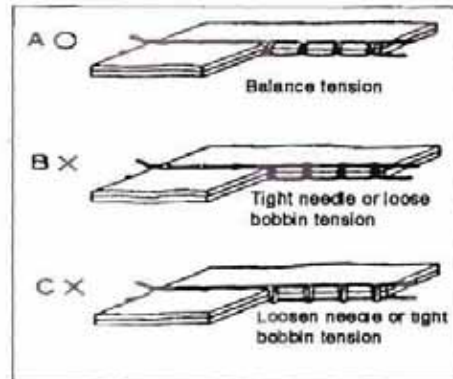

## 10. Needle thread tension

- Needle thread tension should be adjusted in reference to bobbin thread tension.
- To adjust needle thread tension, turn each tension adjusting nut.
- Needle thread tension can be also adjusted for special fabric and thread by changing intensity and movable range of slack thread adjusting spring.

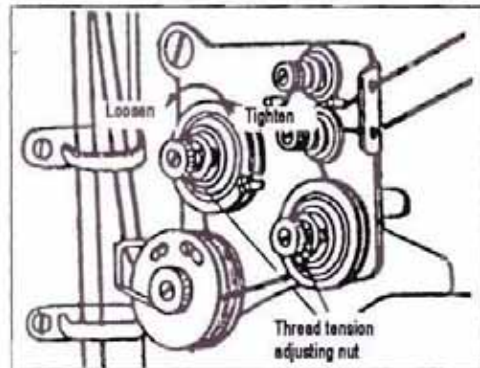

## 11. Adjustment of presser foot pressure

Pressure to fabric(s) can be adjusted by turning the pressure adjusting screw.

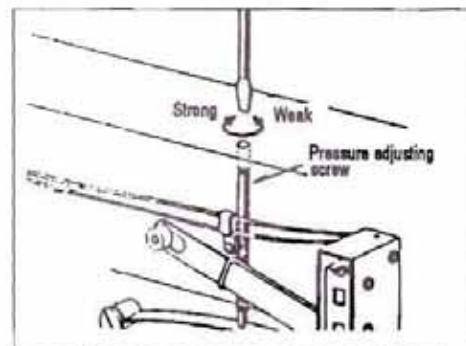

## 12. Timing between rotating hook motion and needle motion

- (1) Set feed length (stitch length) to "6" on the feed setting dial.
- (2) When needle is lifted 2.4mm from the lower dead point, as shown in Figure, the following positional relationship should be maintained.
  - The upper edge of needle eye should be 2.3mm below the hook point.
  - The hook point should be located at the center of needle axis.
  - Gap between the hook point and the side face of needle should be 0.05mm.

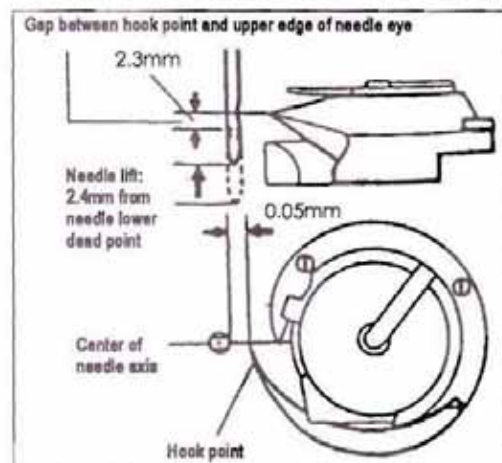

### ■ Positioning of hook point

- (1) When the needle is at DOWN position, the smaller  
Crossed helical gears on the right side and left side  
should be engaged with the large wheel so that the  
"S" screw of the former gear comes on the front side,  
and that of the latter gear on the reverse side.
  - (2) Tighten each "S" screw, where is punched for  
set screw, on the hook shaft.
  - (3) Approximate position of hook "C" screw of hook  
should be found close to the needle when the needle  
is at DOWN position.
- To finely adjust timing between the needle motion and  
hook motion, loosen the set screw of larger gear  
wheel and move the gear wheel in its axial direction  
within a range from 1mm to 2mm.

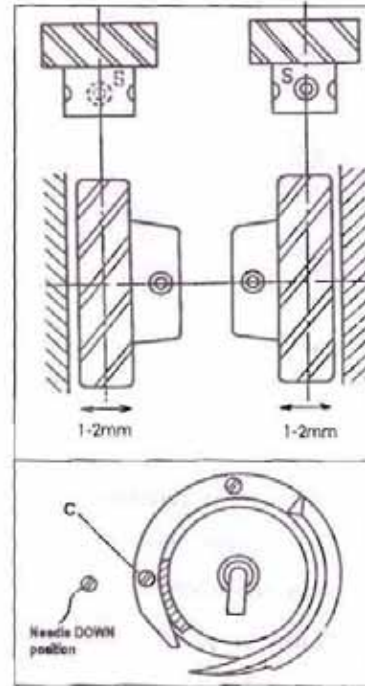

### 13. Adjustment of feed dog height

Height of feed dog and pressure of presser foot should be adjusted for individual fabric(s) with the following cautions:

- Fabric will be damaged if the feed dog extends too high, or pressure of presser foot is too large.
- Even stitch length cannot be assured if the feed dog is too low or pressure of presser foot is too small.
- Feed dog height should be measured at the point where the needle is at the top position.

For light fabrics ..... Approx. 0.8mm from throat plate

For usual fabrics ..... Approx. 1.0mm from throat plate

For heavy fabrics ..... Approx. 1.2mm from throat plate

#### Adjustment procedure

- a) Lean the machine head backward.
- b) Turn the hand wheel by hand and stop when the feed dog rises to the maximum height.
- c) Loosen the feed bar set screw.
- d) Vertically move the feed bar (in the direction indicated by arrow in the figure) to adjust it to adequate height.

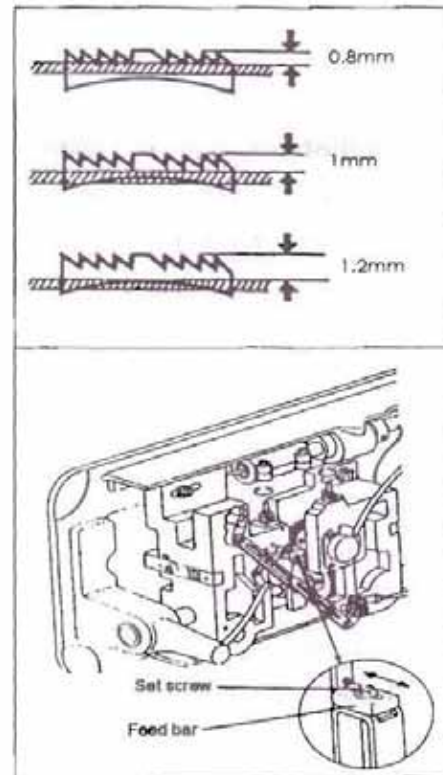

- e) After the adjustment, tighten the feed bar set screw.
- The feed dog height is factory-adjusted to 1.2mm

**14. Relationship between rotating hook motion and take-up lever motion**

When the timing belt (toothed belt) was removed for its replacement, for example, the relationship between rotating hook motion and take-up lever motion should be adjusted as follows:

- Turn the balance wheel and stop when the take-up lever is lifted to its upper dead point.
- Lean the machine head backward and make sure the arrow (timing mark) put on the timing belt is in line with the black line on the boss of lower shaft bearing.
- If the timing mark is not in line with the black line, remove the timing belt and install it again to adjust.

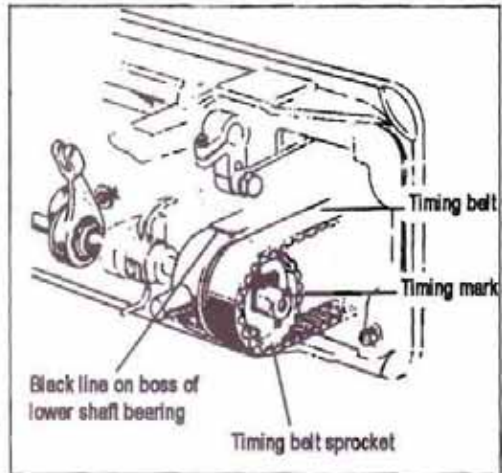

**15. Relationship between hook motion and opener motion**

- Turn the balance wheel by hand and stop when the opener holder is located most remotely from the throat plate.
- Make sure gap between the bobbin case holder A and the opener is approximately 0.2mm.
- If the gap is too large or small, loosen the opener holder set screw B and adjust position of the opener.

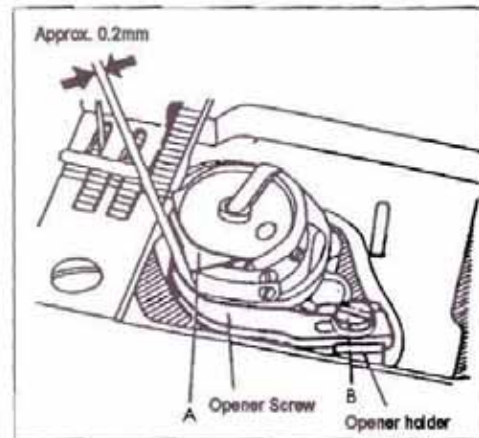

**16. Relationship between needle motion and feed dog motion**

- Set feed length to "0" on the feed setting dial
- Lean the machine head backward.
- Loosen the feed lifting rock shaft crank set screws A and B.
- Set the needle at the lowest position.
- Adjust the distance between presser rod and vibration prevention rod to 9mm and temporarily tighten the feed lifting rock shaft crank set screws A and B
- Check that the right feed lifting rock shaft crank is connected with the link at right angle, as shown in Figure.

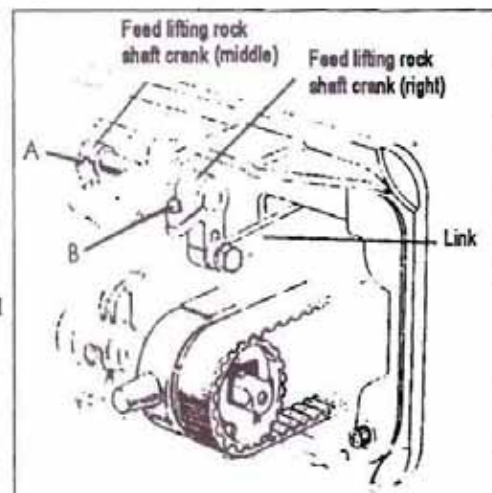

- g) If the connection is not at right angle, remove the back cover, loosen screw C and move the right link to connect the right feed lifting rock shaft with the link at right angle.
- h) After the completion of adjustment, fully tighten the screws A, B and C.
- At this time make certain that needle can enter the feed dog needle hole at the center of the hole.

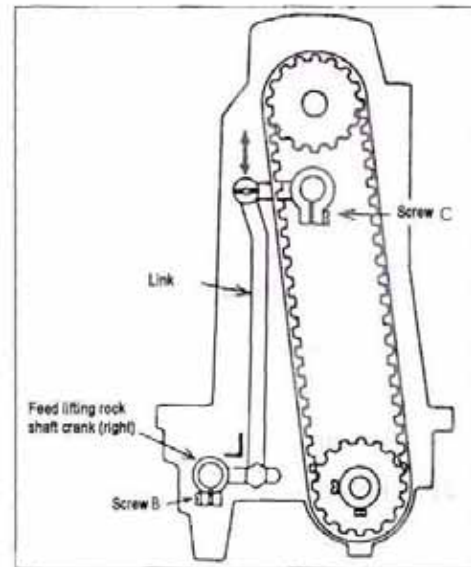
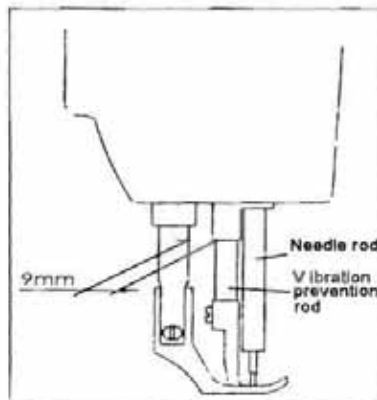

### 17. Safety clutch device:

Safety clutch device is installed to prevent the hook and cog belt from damage in case the thread is caught into the hook when the machine is loaded abnormally during operation.

#### (1) Function of safety clutch.

- When the safety clutch acts, the cog belt pulley will be unloaded. then the rotation of hook shaft will stop. The arm shaft only will rotate. Stop the operation of machine.
- Clean the thread thoroughly which is caught into the hook.
- Turn the cog belt hub by hand, and check whether the hook Shaft rotates lightly and properly, place the clutch device as follows.

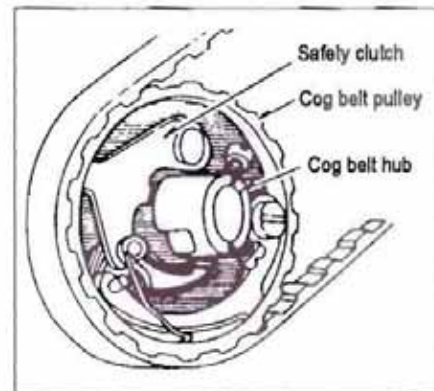

(2) How to set the safety clutch.

- a) While pressing down the push button on the opposite side of bed by left hand, turn the balance wheel slowly by right hand away from you as shown in the figure.
- b) The balance wheel will stop by the gear plate, but turn the balance wheel more firmly.
- c) Release the push button.
- d) As shown in the Figure, the safety clutch device is set.

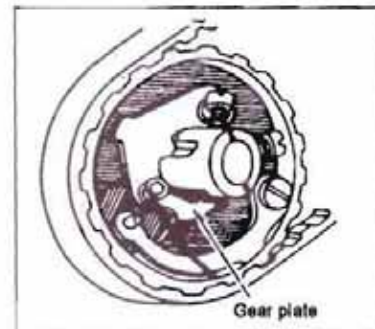
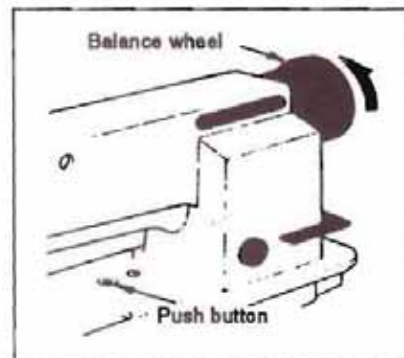

(3) Force applied to the safety clutch.

- a) The force applied to the safety clutch is the smallest when the white mark of the eccentric pin faces the center of the lower shaft. The force proportionally increases as the white mark faces the outside.
- b) To adjust the force slide the timing belt, loosen the set screw, and turn the eccentric pin.
- c) After the adjustment, make sure to fasten the set screw.

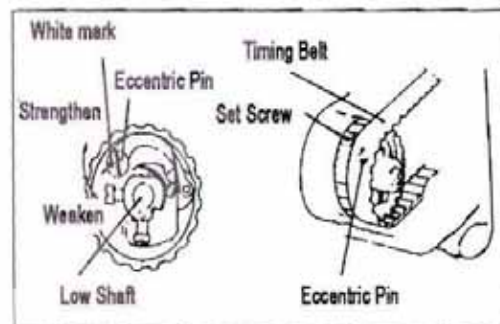

18. Upper feed adjustment

(Needle side)

If the uneven feeding occurs according to the fabric, adjust the long hole of the horizontal feed shaft crank (right) to adjust the upper feed length.

(How to adjust)

- a) Loosen the special bolt.
- b) Move the special bolt upward to decrease upper feed.
- c) Move the special bolt downward to increase the upper feed. The upper feed and the lower feed theoretically becomes equal at the reference line on the horizontal feed shaft crank.
- d) Securely tighten the special bolt after adjustment.

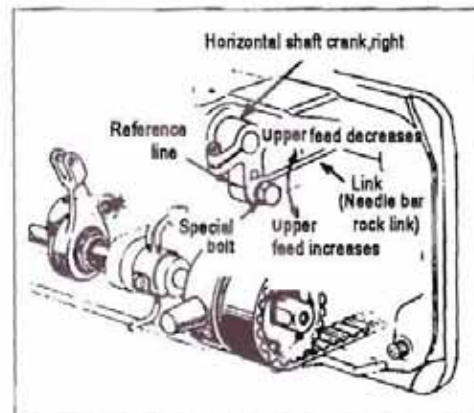



## 19. Outside presser foot and inside presser vertical stroke adjustment

When fabric with large elasticity is sewn, or when thickness of fabric changes, the vertical stroke (movable range) of the presser feet should be adjusted as follows:

### Adjustment

- a) Loosen the special bolt.
- b) The vertical strokes of the presser feet become
- c) maximum when the crank rod is moved upward and set.
- d) The vertical strokes becomes minimum when the nut is moved downward and set.
- e) After the adjustment, fully tighten the special bolt.

- The vertical strokes of the presser feet can be adjusted within a range from 6mm to 2mm.

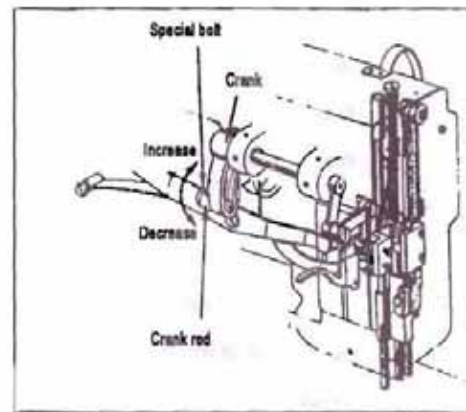

## 20. Adjustment

Screwing the pin that connects the link of back-sewing with the crank of back-sewing (down) can adjust the tolerance of between the stitches. Screwing the pin in clockwise can increase the stitch of forward sewing; otherwise, the stitch of back-sewing will be increased.

## 21. Installation of movable knife

### (1) Installation of movable knife

- a. Turn the balance wheel and lower the needle bar to the lowest position.
- b. Push the cam follower crank so that the cam roller enters into the thread trimmer cam groove.
- c. Turn the balance wheel until the black mark point on the arm meets the white mark point on the balance wheel. Set the cam follower crank at this position with a screwdriver temporarily preventing the cam roller coming out from the cam groove.
- d. Loosen the thread trimmer rocking crank clamp bolts A and B.
- e. Adjust the movable knife so that the movable knife end slant portion protrudes 0-0.5 mm from the fixed knife, as shown in Figure and tighten the bolts A and B.

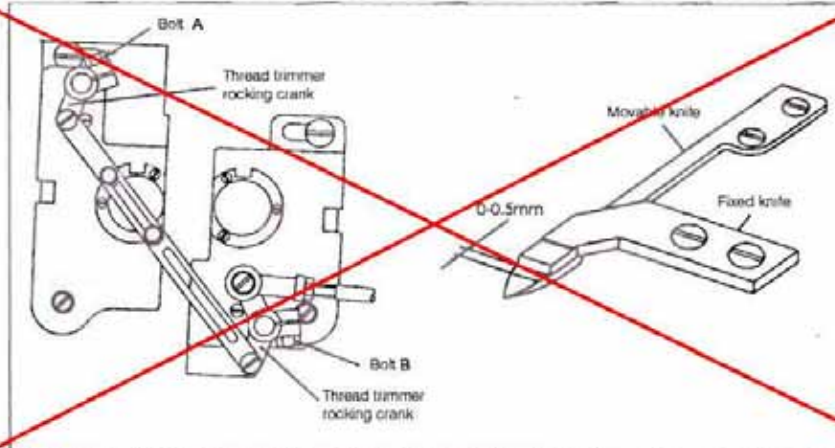

(2) **Gap between movable knife and bobbin case holder stopper**

- Turn the balance wheel by hand until needle reaches the Lowest position.
- With the needle at the lowest position, depress cam follower crank, turn the balance wheel until the movable knife reaches the extremity of its stroke.
- Manually rotate the inner hook in the direction indicated by arrow in Figure and adjust gap between the movable knife

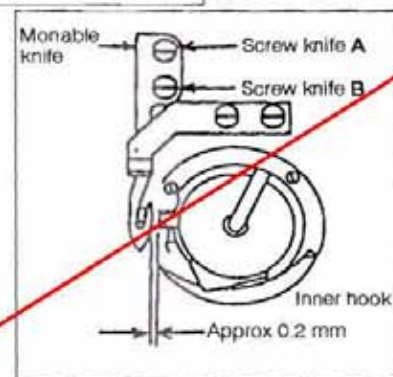

and the inner hook stopper to about 0.5 mm (the screws A and B should be loosened for this adjustment).

22. **Adjustment of thread trimmer cam**

- Turn the balance wheel by hand until the needles reach the lowest position.
  - Maintaining the needle position, depress the cam follower crank and put the cam roller into the groove of thread trimmer cam.
  - Turning the balance wheel by hand, adjust the thread trimmer cam so that the movable knife starts moving, when the green mark point on the balance wheel comes in line with the black mark point on the arm.
- To adjust, loosen two thread trimmer cam clamp screws A.

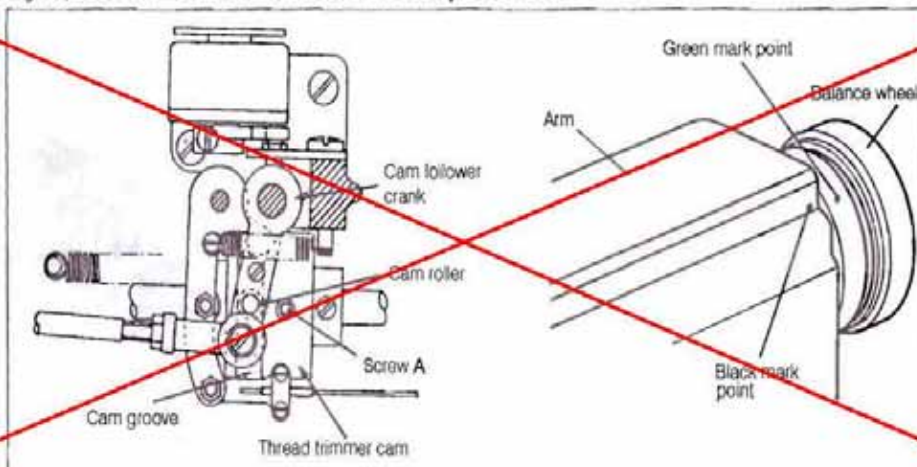

### 23. Adjustment of needle threads tension release assembly

- a. Turn the balance wheel by hand until the needles reach the lowest position.
- b. Maintaining the needle position, depress the cam follower crank and put the cam roller into the groove of thread trimmer cam.
- c. Turning the balance wheel by hand, adjust the thread tension release cam so that the tension disc close when the white mark point on the balance wheel comes in line with the black mark point on the arm. To adjust, loosen two tension release cam clamp screws A.
- d. Opening degree of tension disc should be adjusted with the tension release roller B mounted on the convex portion of thread release cam, as shown in Fig. To adjust, loosen the screws C and draw the wire.
- e. Make fine adjustment by loosening the nut D.
- f. Loosen the nut D and make the outer casing approach rightward to increase the opening value.

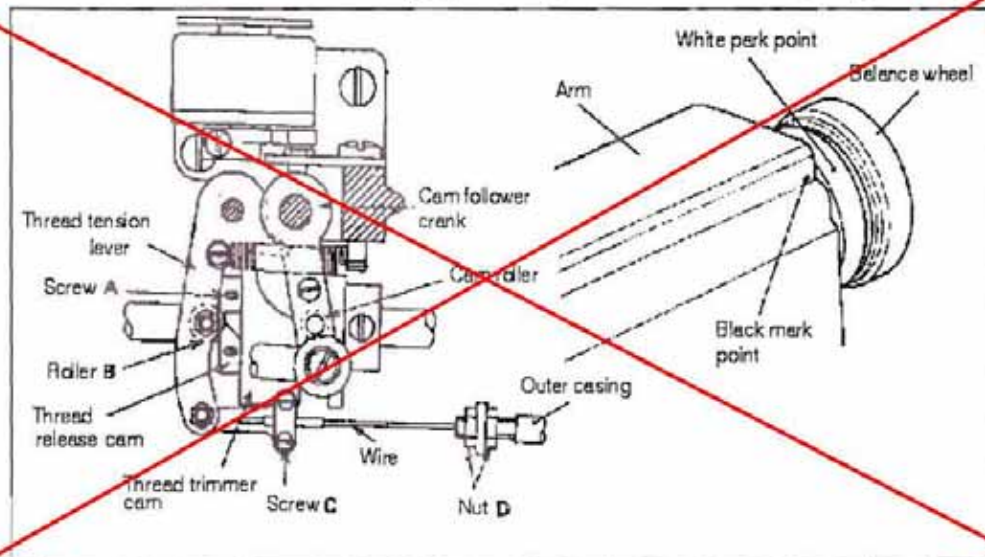

### 24. Adjustment of scissoring pressure of movable knife and fixed knife

- a. Loosen the fixed knife bracket clamp bolt A.
- b. Turn the vertical position adjusting screw B to adjust meshing pressure and then tighten the hexagon socket head cap screw A.

Note: Since excess pressure causes large torque to the thread trimming mechanism and trimming failure, adjust it so that thread can be trimmed with minimum pressure.

- c. Move the movable knife and check that the thread can be sharply trimmed.

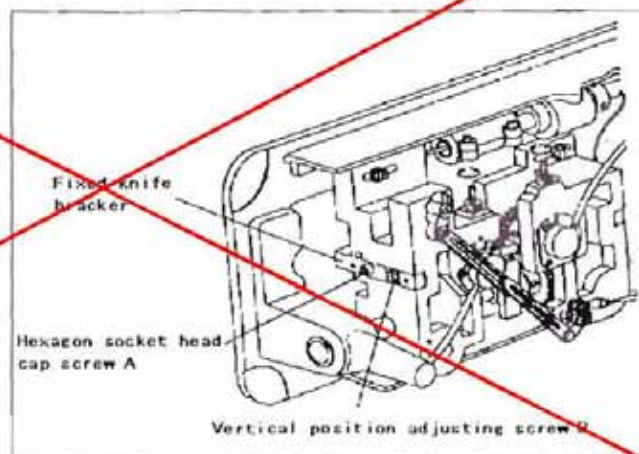

## 25. Sharpening of fixed knife

When the knives dull, the fixed should be sharpened as illustrated in Fig.

Since it is very difficult to sharpen the movable knife, replace it with a new one when it dulls.

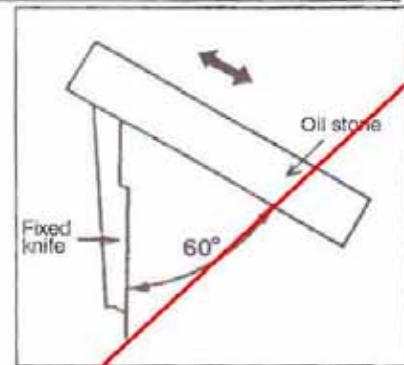

## 26. Adjustment for change of needle-to-needle distance

- (1) Replace the throat plate, feed dog and needle clamp.

(Since the throat plate and feed dog are special parts designed for thread trimming machine, be sure to use those specified by us.)

- (2) Lean the machine head backward.

- (3) Loosen two connecting link clamp bolts J.

- (4) Remove the spring M.

- (5) Loosen the hook bracket clamp screws A and B and adjust gap between each needle and hook.

- (6) When the needles and hooks have been adjusted, install the spring M.

- (7) Contact the rocking cranks

C and D to the stopper pins E and F and tighten the connecting link clamp bolt J.

- (8) Turn the balance wheel by band until the needles reach the lowest position.

- (9) Loosen the nuts G and H.

- (10) Depress the cam follower crank K and adjust the connecting rod L so that the cam roller can smoothly enter the groove of thread trimmer cam.

- (11) Adjustment of the cam groove and the cam roller

- i. Push the cam follower crank K so that the cam roller enters into the cam groove.
- ii. Turn the connecting rod L and adjust the clearance between the cam roller and the cam groove surface L as small as possible, and tighten the nuts G and H.
- iii. Push the cam follower crank K again and check that the cam roller enters into the thread trimmer cam groove smoothly.

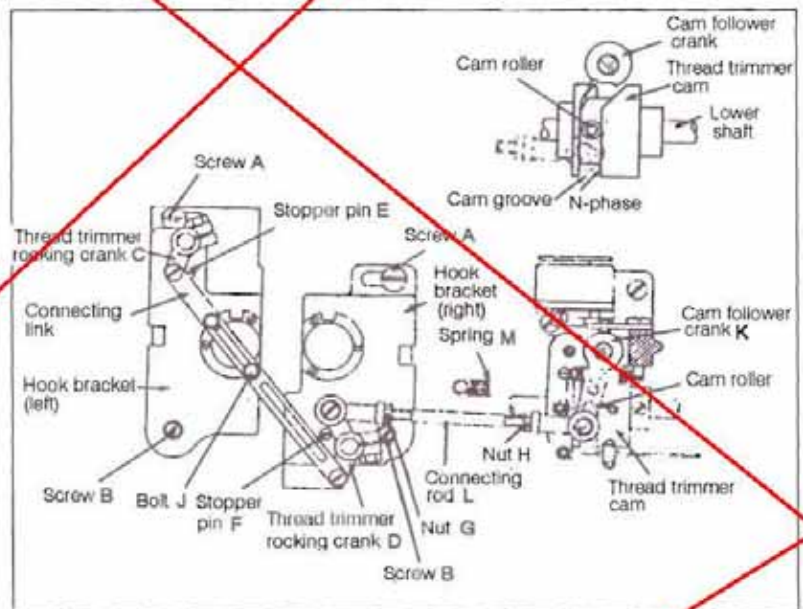

## SPECIFICATIONS

Model	4400-LA25	4420-LA25	4400-LA25 D1	4420-LA25 D1					
Number	Single-needle	Double-needle	Single-needle	Double-needle					
Application	Heavy material								
Max. sewing speed	1800(rpm)								
Stitch length	0~9(mm)								
Thread take-up lever stroke	74.5(mm)								
Needle-bar stroke	36(mm)								
Presser-foot stroke	16(mm) by Leg		8(mm) by hand						
Vertical stroke of upper feed	2~6(mm)								
Needle No.	<b>135 x 17 Fabrics, 135 x 16 Leather</b>								
Hook	(Horizontal full-rotating) Large								
Thread take-up lever	Slide lever								
Stitch adjusting system	Dial								
Lubrication system	Manual lubrication								
Motor	Artisan Electronic Servo Motor								
Needle gauge	Standard	6.4(mm)							
	Special	3.2	4	4.8	8	9.5	12.7	16	19

- Note:** ◆ Some materials, gauge sizes, and/or sewing conditions may require specifications other than those listed above.
- ◆ Feed dog, throat plate, rotating hook, bobbin case and bobbin should be those designed for thread timer.
  - ◆ Bobbin should be of high quality free from deformation.
  - ◆ This specification is subject to change for machine improvement.

## A.ARM BED AND ITS ACCESSORIES

---

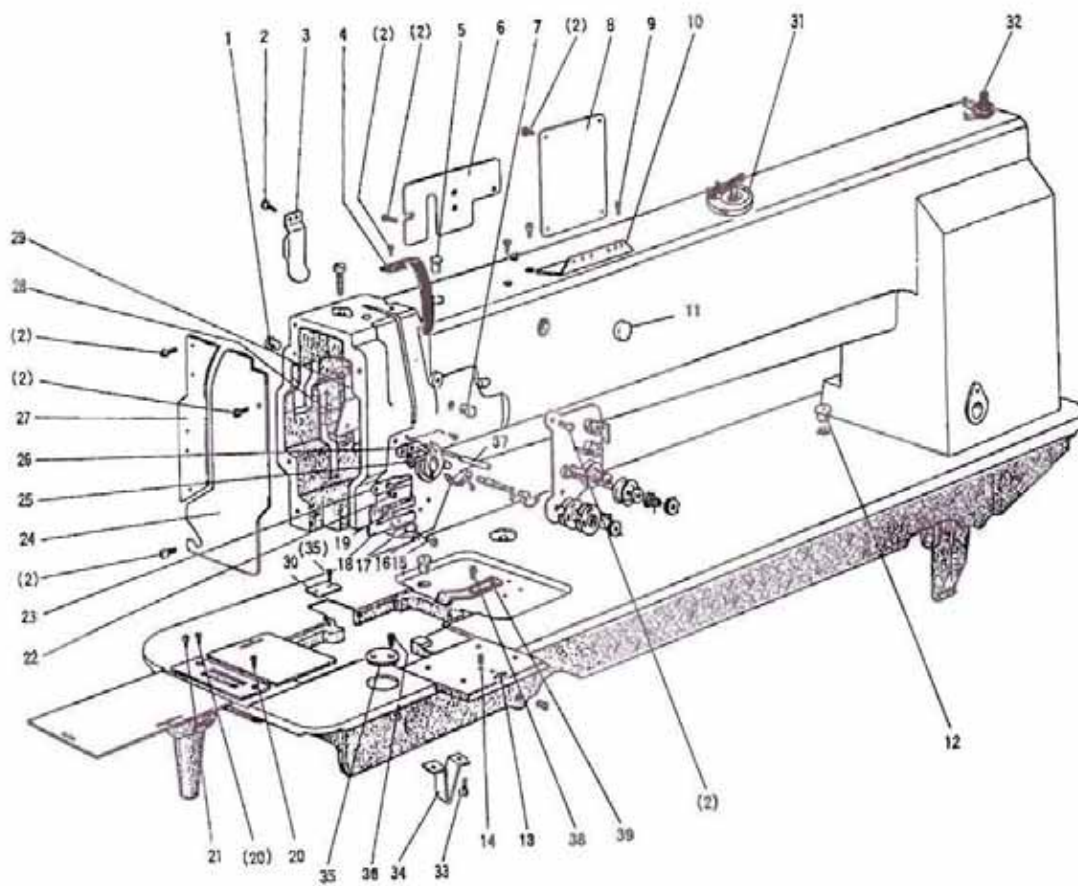

## A. ARM BED and ACCESSORIES

Fig. No.	Part No.	Description	4400 LA-25	4420 LA-25	4400 LA-25 DI	4420 LA-25 DI	Remarks
A01	HA300B2090	Rubber plug	2	2	2	2	
A02	HA300B2170	Screw	15	15	15	15	SM11/64 (40) ×8
A03	H4716B8001	Oil guard plate	1	1	1	1	
A04	H4717B8001	Thread take-up cover	1	1	1	1	
A05	H4715B8001	Rubber plug	1	1	1	1	φ13
A06	H4718B8001	Side cover (left)	1	1	1	1	
A07	H2000B2010	Rubber plug	1	1	1	1	φ13
A08	H4919B8001	Side cover (right)			1	1	
A08	H4719B8001	Side cover (right)	1	1			
A09	HA700B2060	Screw	2	2	2	2	SM11/64 (40) ×8
A10	H2400B2100	Thread guide	1	1	1	1	
A11	HA307B0673	Rubber plug	1	1	1	1	
A12	H2000M0080	Cap	2	2	2	2	
A13	H3219B0067	Slide plate complete		1		1	
A14	H3200B2170	Screw		1		1	SM13/64 (32) ×4.8
A15	H4722B8001	Screw	1	1	1	1	SM1/8 (44) ×3
A16	H4723B8001	Spring	1	1	1	1	
A17	H4724B8001	Plate	1	1	1	1	
A18	H4725B8001	Thread guide	1	1	1	1	
A19	H3200B2100	Screw	1	1	1	1	SM9/64 (40) ×6.5
A20	HA300B2190	Screw	2	1	2	1	SM11/64 (40) ×8
A21	H3200B2120	Screw		1		1	SM9/64 (36) ×6.5
A22	H3000D2160	Screw	1	1	1	1	SM9/64 (40) ×6.5
A23	H4726B8001	Thread guide (middle)	1	1	1	1	
A24	H4727B8001	Face plate	1	1	1	1	
A25	H2400B2080	Screw	2	2	2	2	SM3/16 (28) ×11
A26	H2400B2070	Thread guide (upper)	1	1	1	1	
A27	H4730B8001	Guide mounting plate	1	1	1	1	
A28	H2400B2060	Plate for oil guard	1	1	1	1	
A29	H3200B2060	Oil guard	1	1	1	1	
A30	H4911B8001	Cover				1	
A30	H5015B8001	Cover			1		
A31	H7007D7101	Bobbin complete	1	1	1	1	
A32	H7014D7101	Down-lead complete	1	1	1	1	
A33	H4912B8001	Screw			2	2	SM1/4 (24) ×9
A34	H4913B8001	Supporter			1	1	
A35	H4915B8001	Cover				1	
A36	H4914B8001	Screw			2	4	SM9/64 (40) ×6
A37	H4916B8001	Pin			1	1	
A38	H4742E8001	Screw	2		2		SM11/64 (40) ×6
A39	H4751B8001	Tension releasing plate	1		1		

## B.THREAD TENSION REGULATOR MECHANISM

---

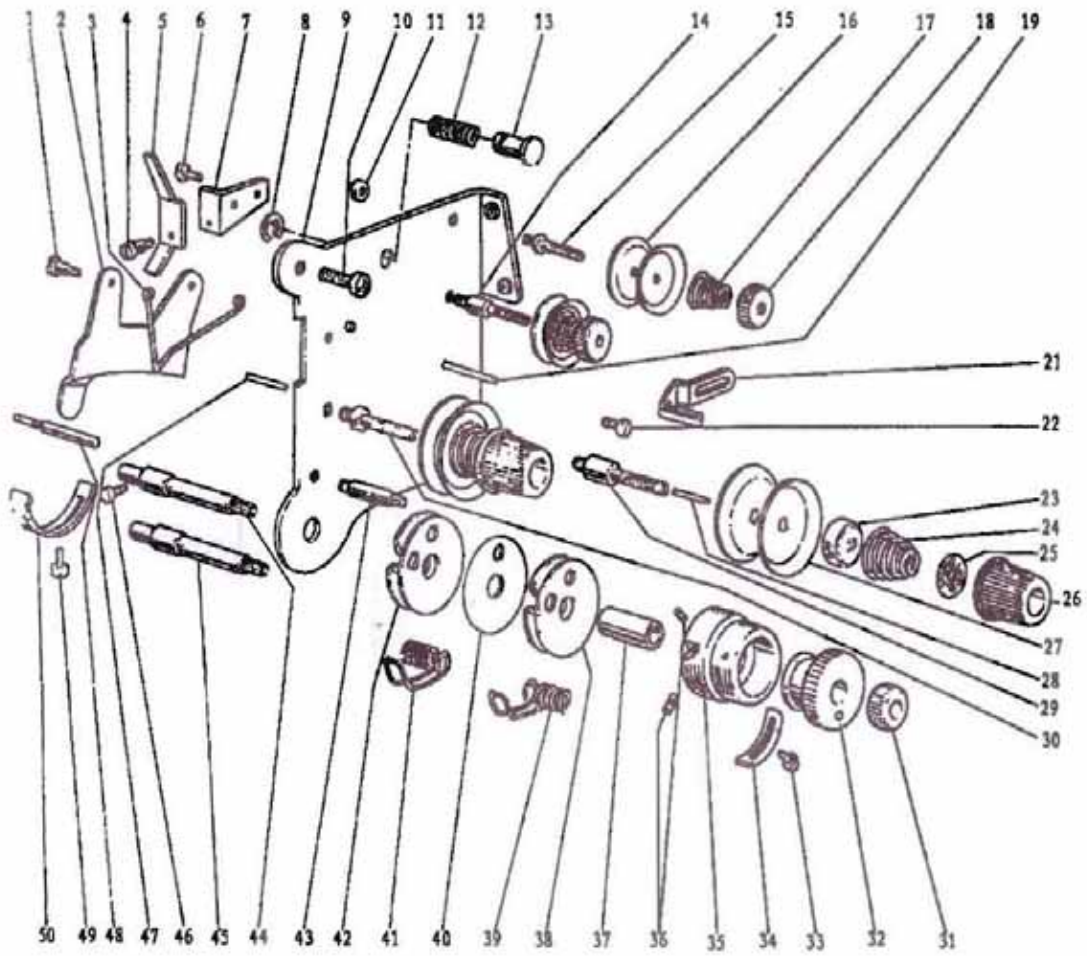



## B.THREAD TENSION REGULATOR MECHANISM

Fig. No.	Part No.	Description	4400 LA-25	4420 LA-25	4400 LA-25 D1	4420 LA-25 D1	Remarks
B01	H3221B6811	Screw	2	2	2	2	SM9/64 (40)
B02	H3221B3142	Tension releasing plate	1	1	1	1	
B03	H3221B6812	Tension releasing spring	1	1	1	1	
B04	H4705C8001	Screw	1	1	1	1	SM9/64 (40)
B05	H4706C8001	Lever	1	1	1	1	
B06	HA7311C306	Screw	1	1	1	1	SM9/64 (40) ×4.5
B07	H4707C8001	Mounting plate	1	1	1	1	
B08	H007013050	Stop ring	1	1	1	1	GB/T896 5
B09	H3221B6820	Mounting plate	1	1	1	1	
B10	HA300C2030	Screw	2	2	2	2	
B11	H3221B6810	Nut	1	1	1	1	SM11/64 (40)
B12	H4708C8001	Spring	1	1	1	1	
B13	H4709C8001	Push button	1	1	1	1	
B14	H3221B0685	Thread tension stud		1		1	
B15	H3221B0683	Thread tension stud	1	1	1	1	
B16	HA112B0693	Thread tension disk	2	4	2	4	
B17	H3221B0684	Thread tension spring	1	2	1	2	
B18	HA710B0671	Thumb nut	1	2	1	2	
B19	H3221B0682	Pin	2	3	2	3	
B21	H3306B0661	Thread guide	1	1	1	1	
B22	HA106B0676	Screw	1	1	1	1	SM9/64 (40) ×6
B23	HA310B0702	Thread tension releasing plate	1	2	1	2	
B24	H4710C8001	Thread tension spring	1	2	1	2	
B25	HA115B7010	Thumb nut revolution stopper	1	2	1	2	
B26	HA310B0701	Thumb nut complete	1	2	1	2	
B27	HA310B0705	Thread tension disk	2	4	2	4	
B28	H3221B6816	Pin		1		1	
B29	H3221B0689	Thread tension stud		1		1	
B30	H3221B0686	Thread tension stud	1	1	1	1	
B31	H32481B721	Thumb nut	1	1	1	1	SM1/4 (40)
B32	H32481B621	Take-up spring guide		1		1	
B33	H32481BC21	Screw		1		1	SM9/64 (40) ×6
B34	H32481BB21	Stopper		1		1	
B35	H32481B921	Thread tension post		1		1	
B36	H32481B521	Screw		2		2	SM1/8 (44) ×3.9
B37	H32481B821	Bushing		1		1	
B38	H32481BF21	Plate complete		1		1	
B39	H4712C8001	Thread take-up spring		1		1	
B40	H32481BE21	Plate		1		1	
B41	H4713C8001	Thread take-up spring	1	1	1	1	
B42	H32481BD21	Plate complete	1	1	1	1	
B43	H4804C8001	Screw	1		1		
B43	H32481B421	Screw		1		1	SM9/64 (40) ×2.9

## B.THREAD TENSION REGULATOR MECHANISM

Fig. No.	Part No.	Description	4400 LA-25	4420 LA-25	4400 LA-25 D1	4420 LA-25 D1	Remarks
B44	H32481B121	Thread tension stud		1		1	
B45	H4805C8001	Thread tension stud	1		1		
B46	H3230K0751	Screw	1	1	1	1	SM11/64 (40) ×10
B47	H3221B6817	Pin	1	1	1	1	
B48	H3221B6818	Tension releasing pin	1	1			
B48	H4916B8001	Tension releasing pin			1	1	
B49	H3200B2100	Screw	1	1	1	1	SM9/64 (40) ×6.5
B50	H3221B6819	Stopper	1	1	1	1	

## C.ARM SHAFT MECHANISM

---

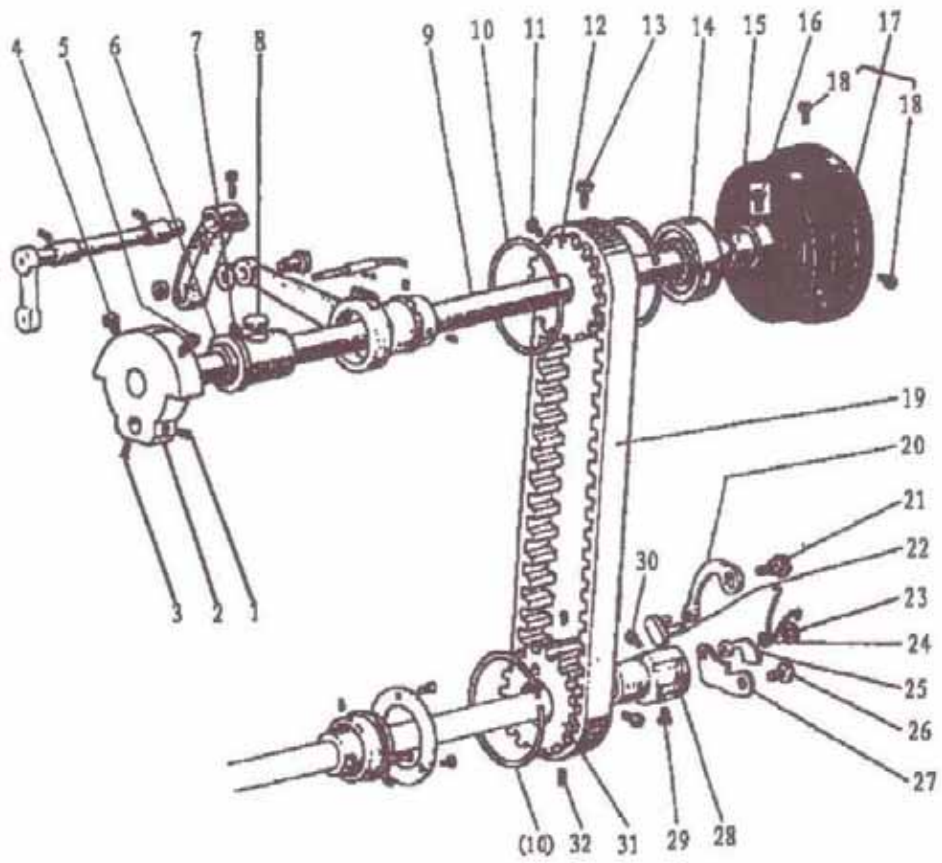

## C.ARM SHAFT MECHANISM

Fig. No.	Part No.	Description	4400 LA-25	4420 LA-25	4400 LA-25 D1	4420 LA-25 D1	Remarks
C01	HA307C0662	Set screw	1	1	1	1	SM1/4 (40) ×7
C02	H4706D8001	Crank	1	1	1	1	
C03	HA105D0662	Screw	1	1	1	1	SM1/4 (40) ×3.5
C04	HA100C2060	Set screw	1	1	1	1	SM9/32 (28) ×14
C05	HA100C2070	Screw	1	1	1	1	SM9/32 (28) ×13
C06	H32111B204	Arm shaft bushing (left)	1	1	1	1	
C07	H4708D8001	Screw	1	1	1	1	SM1/4 (24) ×13
C08	H32111B104	Felt	1	1	1	1	
C09	H7004D8001	Arm shaft	1	1	1	1	
C10	H3205C0661	Spring flange	3	3	3	3	
C11	HA113F0684	Screw	1	1	1	1	SM15/64 (28) ×8.5
C12	H3205C1021	Belt pulley (upper)	1	1	1	1	
C13	HA100F2130	Screw	1	1	1	1	SM15/64 (28) ×14.5
C14	H3205J0662	Bearing	1	1			
C15	H3205J0661	Collar	1	1			
C16	HA113F0684	Screw	2	2			SM15/64 (28) ×8.5
C17	H3204J0652	Pulley	1	1			
C18	HA110D0672	Screw	2	2			SM11/64 (28) ×12
C19	H3200C2030	Cog belt	1	1	1	1	
C20	H4713D8001	Spring plate	1	1	1	1	
C21	H4714D8001	Pin	1	1	1	1	
C22	H4715D8001	Link	1	1	1	1	
C23	H007013025	E-type stop ring	1	1	1	1	GB/T896 2.5
C24	H4716D8001	Twist spring	1	1	1	1	
C25	H4717D8001	Plate	1	1	1	1	
C26	H4718D8001	Pin	1	1	1	1	
C27	H4719D8001	Plate	1	1	1	1	
C28	H4720D8001	Bushing	1	1	1	1	
C29	H4721D8001	Screw	1	1	1	1	SM15/64 (28) ×10.5
C30	HA104F0654	Screw	1	1	1	1	SM15/64 (28) ×10
C31	H4722D8001	Belt pulley (lower)	1	1	1	1	
C32	H4723D8001	Screw	2	2	2	2	SM15/64 (28) ×4.5

## D. UPPER SHAFT & PRESSER FOOT MECHANISM

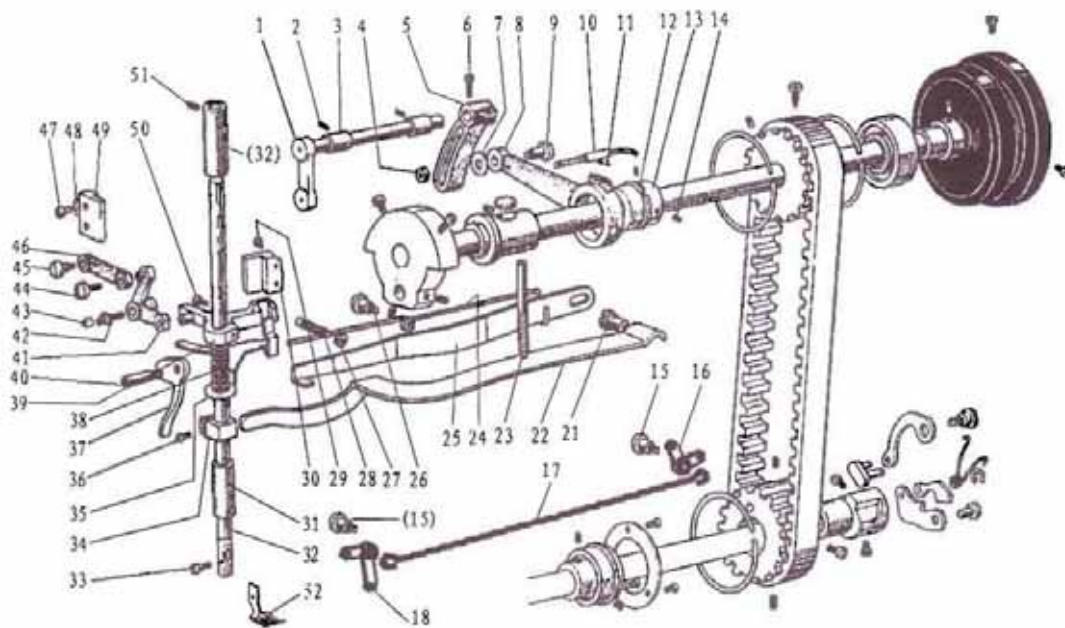

## D. UPPER SHAFT & PRESSER FOOT MECHANISM

Fig. No.	Part No.	Description	4400 LA-25	4420 LA-25	4400 LA-25 D1	4420 LA-25 D1	Remarks
D01	H4705E8001	Feed lifting rock shaft	1	1	1	1	
D02	H4706E8001	Screw	2	2	2	2	SM1/4 (24) ×7
D03	H4707E8001	Bushing	2	2	2	2	
D04	HS91165206	Nut	1	1	1	1	M6×0.75
D05	H4709E8001	Lever	1	1	1	1	
D06	H3115F0671	Screw	1	1	1	1	SM1/4 (28) ×16
D07	H2013J0065	Washer	1	1	1	1	
D08	H2014J0066	Connecting rod	1	1	1	1	
D09	H2000J2100	Bolt	1	1	1	1	
D10	H4713E8001	Oil pipe & wick complete	1	1	1	1	
D11	H20111C106	Spring	1	1	1	1	
D12	H007009250	C-type stop ring	1	1	1	1	GB/T894.1 25
D13	H4714E8001	Eccentric	1	1	1	1	
D14	HA307C0662	Screw	2	2	2	2	SM1/4 (40) ×6
D15	H7008E8001	Screw	2	2	2	2	SM1/4 (24) ×14
D16	H7009E8001	Plate (B)	1	1	1	1	
D17	H7007E8001	Plate	1	1	1	1	
D18	H7005E8001	Plate (A)	1	1	1	1	
D21	H3100G2170	Screw	1	1	1	1	SM1/4 (24) ×17
D22	H4730E8001	Lever spring	1	1	1	1	
D23	H4729E8001	Screw	1	1	1	1	SM15/64 (28) ×79
D24	H4727E8001	Twist spring	1	1	1	1	
D25	H4728E8001	Knee lifting lever	1	1	1	1	
D26	H3100G2130	Screw	1	1	1	1	SM1/4 (24) ×7
D27	H4726E8001	Nut	1	1	1	1	
D28	H4725E8001	Screw	1	1	1	1	SM1/4 (24) ×19
D29	HA111G0683	Screw	2	2	2	2	SM11/64(40)×12
D30	H4723E8001	Guide	1	1	1	1	
D31	H4744E8001	Bushing	1	1	1	1	
D32	H4754E8001	Presser bar	1	1	1	1	
D33	H3200E2020	Screw	1	1	1	1	SM1/8 (44) ×9
D34	H4746E8001	Spring bracket	1	1	1	1	
D35	H4768E8001	Thread releasing plate	1	1			
D36	H2404I0034	Screw			1	1	SM9/64(40)×8.5
D37	H4748E8001	Lifter lever	1	1	1	1	
D38	H4767E8001	Spring	1	1			
D39	H4752E8001	Bracket	1	1	1	1	
D40	H4749E8001	Screw	1	1	1	1	SM11/64 (40) ×8.5
D41	H4715E8001	Bell crank	1	1	1	1	
D42	H2004J0655	Support shaft	1	1	1	1	
D43	H4717E8001	Roller	1	1	1	1	
D44	H4718E8001	Screw	1	1	1	1	SM11/64(32)×6
D45	H2004J0662	Screw	1	1	1	1	SM1/4(40)×5

### D.UPPER SHAFT & PRESSER FOOT MECHANISM

Fig. No.	Part No.	Description	4400 LA-25	4420 LA-25	4400 LA-25 D1	4420 LA-25 D1	Remarks
D46	H4719E8001	Link	1	1	1	1	
D47	HA100E2150	Screw	2	2	2	2	SM11/64(40)×10
D48	H4722E8001	Washer	2	2	2	2	
D49	H4721E8001	Bell crank guide	1	1	1	1	
D50	H4753E8001	Screw	1	1	1	1	SM11/64(40)×14.5
D51	H4708D8001	Screw	2	2	2	2	SM1/4(24)×13
D52	H4757E8001	Lifting presser foot		1		1	
D52	H3114G8001	Lifting presser foot	1		1		

## E.NEEDLE BAR AND THREAD TAKE-UP MECHANISM

---

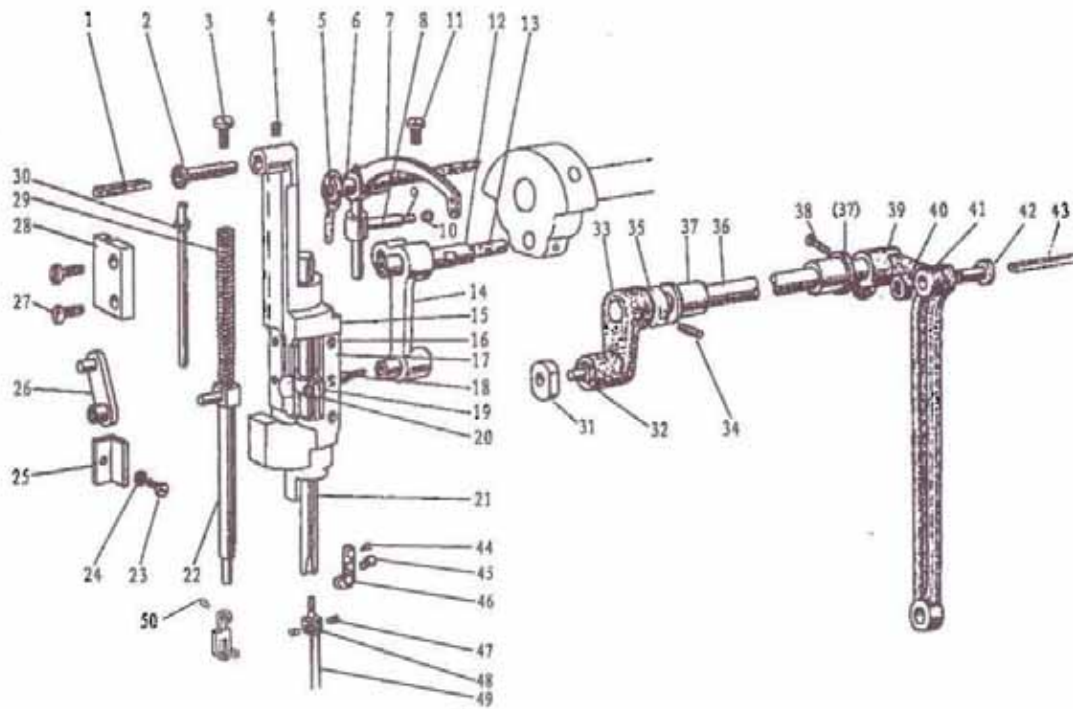



## E.NEEDLE BAR AND THREAD TAKE-UP MECHANISM

Fig. No.	Part No.	Description	4400 LA-25	4420 LA-25	4400 LA-25 DI	4420 LA-25 DI	Remarks
E01	H24211DN05	Oil wick	1	1	1	1	
E02	H4706F8001	Needle bar guide bracket stud	1	1	1	1	
E03	H4707F8001	Screw	1	1	1	1	SM5/16 (28) ×10.4
E04	HA100C2020	Screw	1	1	1	1	SM15/64 (28) ×10
E05	H24211DN05	Oil wick	1	1	1	1	
E06	H24211DM05	Thread take-up lever support stud	1	1	1	1	
E07	H4712F8001	Thread take-up lever	1	1	1	1	
E08	H2405D1112	Thread take-up slide brock	1	1	1	1	
E09	H24211D405	Oil wick	1	1	1	1	
E10	H24211D305	Plug	1	1	1	1	
E11	HA110D0672	Screw	1	1	1	1	SM15/64 (28) ×12
E12	H2405D0662	Needle bar crank pin	1	1	1	1	
E13	H4716F8001	Oil wick	1	1	1	1	
E14	H4717F8001	Connecting link	1	1	1	1	
E15	H4719F8001	Needle bar guide bracket	1	1	1	1	
E16	H32111D304	Screw	6	6	6	6	SM3/32 (56) ×4
E17	H4721F8001	Spacer	2	2	2	2	
E18	H3204D6513	Felt	1	1	1	1	
E19	H4722F8001	Needle bar holder	1	1	1	1	
E20	H32111D604	Screw	1	1	1	1	SM9/64 (40) ×8.5
E21	H4724F8001	Needle bar		1		1	
E21	H4806F8001	Needle bar	1		1		
E22	H4725F8001	Vibrating presser bar	1	1	1	1	
E23	H3400C2020	Screw	1	1	1	1	
E24	H3200I2030	Washer	1	1	1	1	
E25	H3400C2010	Needle bar guide	1	1	1	1	
E26	H4726F8001	Vibrating presser bar link	1	1	1	1	
E27	H4753E8001	Screw	2	2	2	2	SM11/64 (40) ×17.5
E28	H4728F8001	Vibrating presser bar guide	1	1	1	1	
E29	H4729F8001	Spring	1	1	1	1	
E30	H4730F8001	Vibrating presser spring guide	1	1	1	1	
E31	H3410C301P	Square block	1	1	1	1	
E32	H3406C0671	Crank pin	1	1	1	1	SM15/64(28)×10
E33	H3406C0672	Needle bar vibrating crank (left)	1	1	1	1	
E34	H602040240	Taper	1	1	1	1	GB/T117 4×24
E35	H4734F8001	Collar	1	1	1	1	
E36	H7004F8001	Needle bar vibrating shaft	1	1	1	1	
E37	H3204B0652	Needle bar vibrating shaft bushing	2	2	2	2	
E38	H2012N0652	Screw	1	1	1	1	SM1/4 (24) ×16
E39	H3407C0661	Needle bar vibrating crank (right)	1	1	1	1	
E40	H32311D506	Nut	1	1	1	1	
E41	H3407C0662	Connecting link	1	1	1	1	
E42	H32311D306	Screw	1	1	1	1	SM5/16 (24)

### E.NEEDLE BAR AND THREAD TAKE-UP MECHANISM

Fig. No.	Part No.	Description	4400 LA-25	4420 LA-25	4400 LA-25 DI	4420 LA-25 DI	Remarks
E43	H32311D406	Oil wick	1	1	1	1	
E44	H3129F0691	Screw	1		1		SM3/32(56)×2.5
E45	HA100C2170	Screw	1		1		SM1/8(44)×4.5
E46	H3129F0693	Thread guide	1		1		
E47	H32132D104	Screw		2		2	SM9/64(40)×3
E48	H4739F8001	Needle clamp(1//4)		1		1	
E49	H4740F8001	Needle	1	2	1	2	
E50	HA700F2100	Screw	1	1	1	1	SM11/64(40)×7

## F.STITCH REGULATOR MECHANISM

---

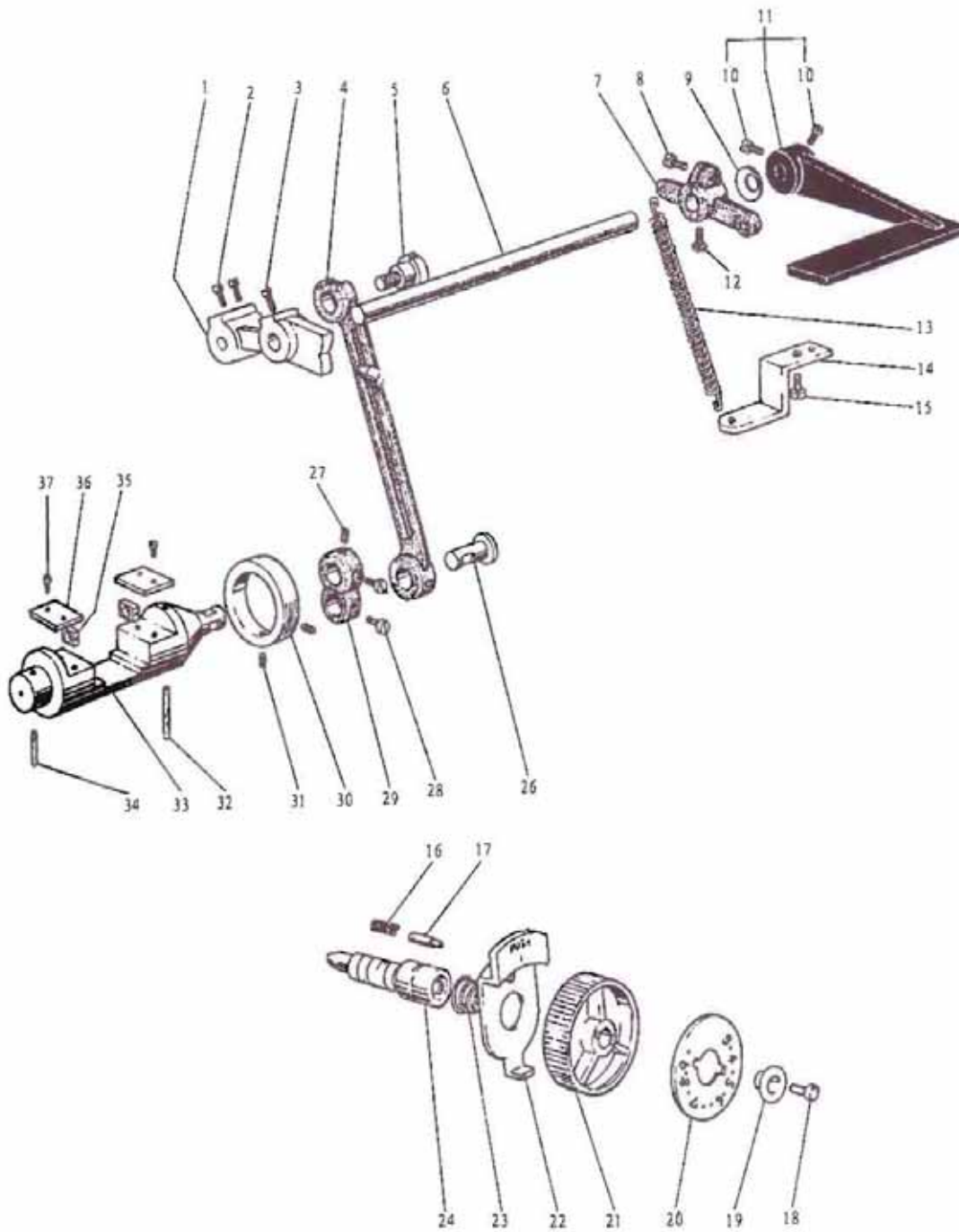

## F.STITCH REGULATOR MECHANISM

Fig. No.	Part No.	Description	4400 LA-25	4420 LA-25	4400 LA-25 DI	4420 LA-25 DI	Remarks
F01	H4706G8001	Feed regulator cam	1	1	1	1	
F02	HA113F0684	Screw	2	2	2	2	SM15/64 (28) ×8.5
F03	H3200F2020	Screw	1	1	1	1	SM15/64 (28) ×12
F04	H4707G8001	Link	1	1	1	1	
F05	HA100G2070	Eccentric shaft	1	1	1	1	
F06	H4709G8001	Reverse stitch shaft (upper)	1	1			
F06	H4909G8001	Reverse stitch shaft (upper)			1	1	
F07	H3207F0671	Arm	1	1			
F07	H4905G8001	Arm			1	1	
F08	HA800F2020	Screw	1	1	1	1	
F09	HA100F2110	Spring Washer	1	1			
F10	HA113F0684	Screw	2	2			
F11	H4711G8001	Reverse sewing lever	1	1			
F11	H4906G8001	Reverse sewing lever			1	1	
F12	H3207F0672	Screw	1	1	1	1	SM11/64 (40) ×8.5
F13	H4710G8001	Spring	1	1	1	1	
F14	H3200F2050	Guide plate	1	1			
F15	HA300C2030	Screw	1	1			SM11/64 (40) ×8
F16	H3200F2110	Spring	1	1	1	1	
F17	HA700F2030	Pin	1	1	1	1	
F18	HA720F0686	Screw	1	1	1	1	SM3/16(28)×18
F19	HA720F0685	Bushing	1	1	1	1	
F20	H4910G8001	Stitch length indicating plate	1	1	1	1	
F21	HA7421F120	Dial	1	1	1	1	
F22	HA720F0683	Stopper pin releasing lever	1	1	1	1	
F23	HA720F0687	Coil spring	1	1	1	1	
F24	HA109F0671	Screw bar	1	1	1	1	
F26	H3206F0662	Pin	1	1	1	1	
F27	H415050200	Screw	1	1	1	1	GB/T70.1 M5×20
F28	H428050060	Screw	2	2	2	2	GB/T77 M5×6
F29	H4714G8001	Reverse sewing crank	1	1	1	1	
F30	H4715G7101	Collar	1	1	1	1	
F31	H43411D308	Screw	2	2	2	2	SM15/64 (28) ×7
F32	H4719G8001	Felt	1	1	1	1	
F33	H4720G8001	Reverse block	1	1	1	1	
F34	H4721G8001	Felt	1	1	1	1	
F35	H4722G8001	Square block	2	2	2	2	
F36	H4723G8001	Guide plate	2	2	2	2	
F37	H4300C2030	Screw	4	4	4	4	SM11/64 (40) ×8

## G.LOWER SHAFT & FEED ROCK SHAFT MECHANISM

---

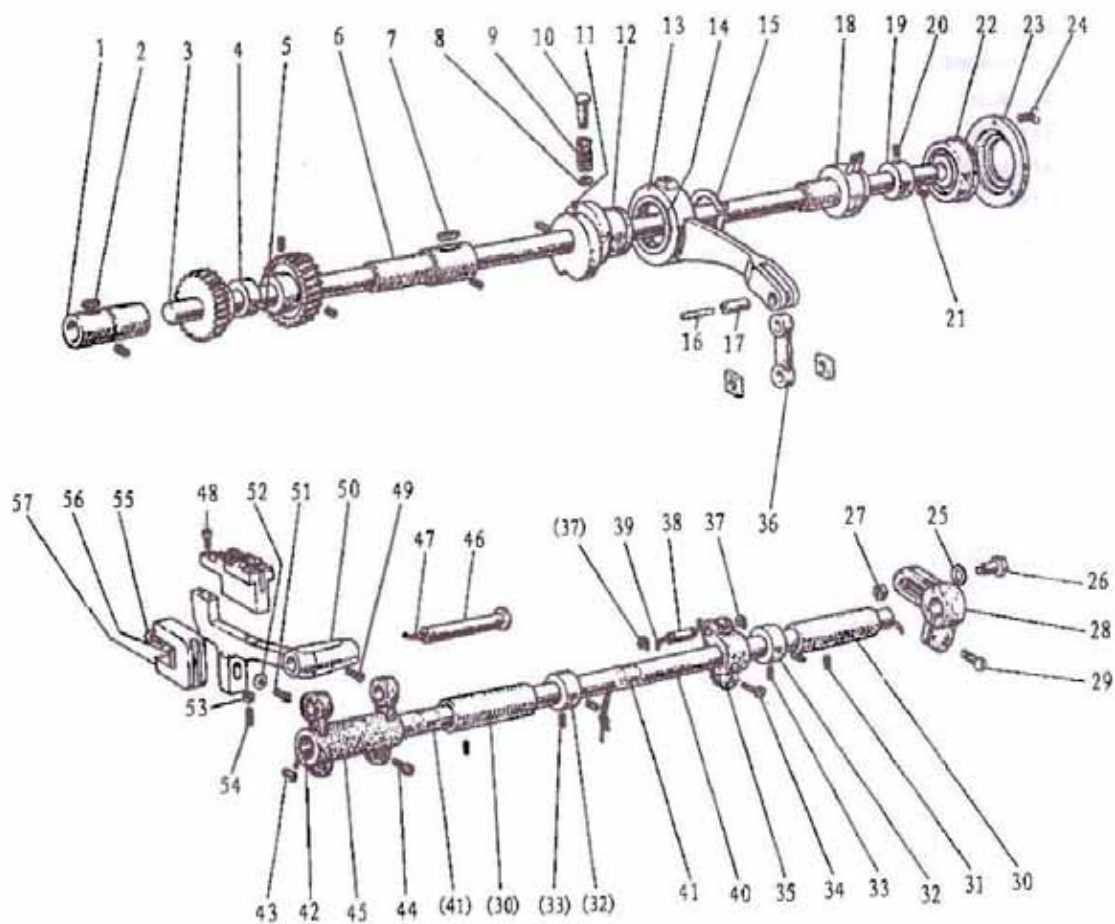

## G.LOWER SHAFT & FEED ROCK SHAFT MECHANISM

Fig. No.	Part No.	Description					Remarks
			4400 L.A-25	4420 L.A-25	4400 L.A-25 D1	4420 L.A-25 D1	
G01	H4706H8001	Lower shaft bushing (left)	1	1	1	1	
G02	H4707H8001	Oil wick	1	1	1	1	
G03	H7004H8001	Lower shaft	1	1	1	1	
G04	H4710H8001	Feed eccentric cam	1	1	1	1	
G05	H3205H0654	Screw	1	1	1	1	SM1/4(40)×5
G06	H4712H8001	Lower shaft bushing (right)	1	1	1	1	
G07	H4713H8001	Oil wick	1	1	1	1	
G08	H007013050	Stop ring	2	2	2	2	GB/T896 5
G09	H4714H8001	Spring	1	1	1	1	
G10	H4715H8001	Push button	1	1	1	1	
G11	H2405D0664	Screw	2	2	2	2	SM15/64(28)×14
G12	H4717H8001	Feed eccentric	1	1	1	1	
G13	H4718H8001	Feed connecting rod	1	1	1	1	
G14	H4719H8001	Needle bearing	1	1	1	1	
G15	H007009260	C-type stop ring	1	1	1	1	GB/T894.1 26
G16	H4720H8001	Oil wick	1	1	1	1	
G17	H4721H8001	Shaft	1	1	1	1	
G18	H7006H7101	Lower shaft bushing complete (middle)	1	1	1	1	
G19	H4725H8001	Bushing	1	1	1	1	
G20	HA105D0662	Screw	1	1	1	1	SM1/4 (40) ×4
G21	H3205H0654	Screw	1	1	1	1	SM1/4 (40) ×5
G22	H4723H8001	Ball bearing	1	1	1	1	
G23	H4727H8001	Bearing holder	1	1	1	1	
G24	HA7311C306	Screw	3	3	3	3	SM9/64 (40) ×7
G25	H4728H8001	Washer	1	1	1	1	
G26	H4729H8001	Screw	1	1	1	1	M6
G27	HS91165206	Nut	1	1	1	1	GB52008 M6
G28	H4731H8001	Feed connection crank (right)	1	1	1	1	
G29	H2012N0652	Screw	1	1	1	1	SM1/4 (24) ×16
G30	HA100G2120	Feed rock shaft bushing	2	2	2	2	
G31	H4708D8001	Screw	2	2	2	2	SM1/4 (24) ×13
G32	HA108G0661	Collar	2	2	2	2	
G33	HA105D0662	Screw	4	4	4	4	SM1/4 (40) ×4
G34	H2012N0652	Screw	1	1	1	1	SM1/4(24)×16
G35	H4736H8001	Feed connection crank (middle)	1	1	1	1	
G36	H4737H8001	Link	1	1	1	1	
G37	H007013050	E-type stop ring	2	2	2	2	GB/T896 5
G38	H4738H8001	Pin	1	1	1	1	
G39	H4739H8001	Oil wick	1	1	1	1	
G40	H7005H8001	Feed rock shaft	1	1	1	1	
G41	H4740H8001	Felt	2	2	2	2	
G42	H3204G0031	Oil wick	1	1	1	1	
G43	H3200G2030	Clip	1	1	1	1	

### G.LOWER SHAFT & FEED ROCK SHAFT MECHANISM

Fig. No.	Part No.	Description	4400 LA-25	4420 LA-25	4400 LA-25 D1	4420 LA-25 D1	Remarks
G44	HA104G0012	Screw	2	2	2	2	SM3/16 (28) ×12
G45	H4905H8001	Feed connection crank (left)			1	1	
G45	H3205G1032	Feed connection crank (left)	1	1			
G46	H32243G205	Feed bar shaft	1	1	1	1	
G47	H3205G0662	Oil wick	1	1	1	1	
G48	H32211G205	Bolt	2	2	2	2	SM1/8 (40) ×7
G49	H429050050	Bolt	1	1	1	1	GB/T78 M5×5
G50	H4742H8001	Feed bar		1			
G50	H4805H8001	Feed bar	1		1		
G50	H4942H8001	Feed bar				1	
G51	H3200H2040	Screw	1	1	1	1	SM15/64 (28) ×17
G52	H2013J0065	Washer	1	1	1	1	
G53	H003002030	Nut		1		1	GB/T6170 M3
G54	H429030140	Screw		1		1	GB/T78 M3×14
G55	H3205H0653	Screw	1	1	1	1	SM1/8 (44) ×4
G56	H3205H0652	Felt	1	1	1	1	
G57	H4743H8001	Feed bar forked connection	1	1	1	1	

# H.HOOK SADDLE MECHANISM

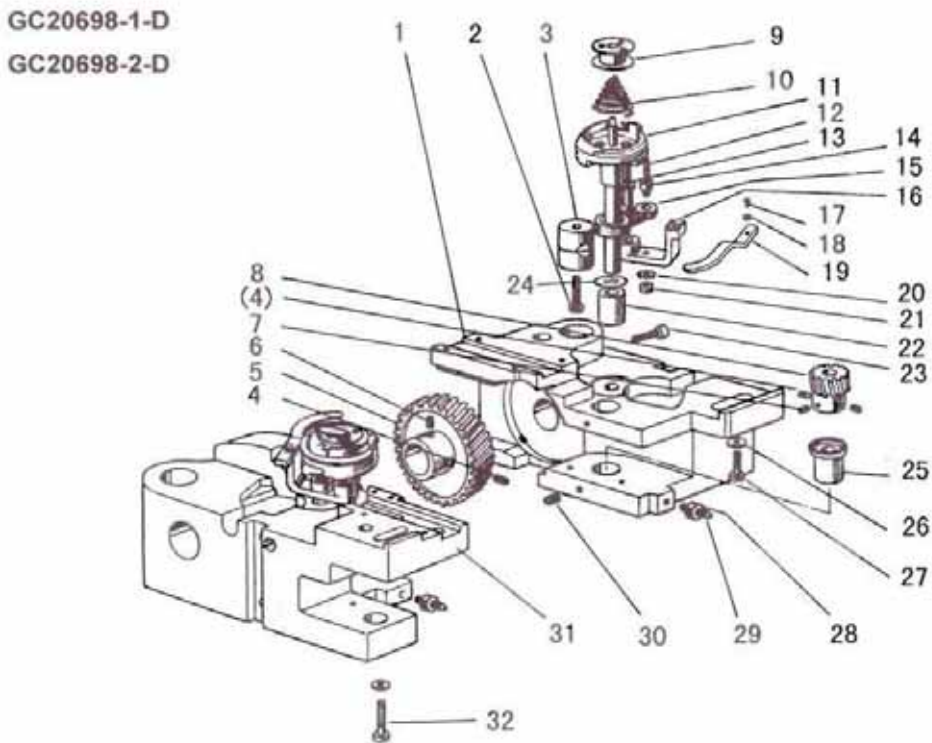
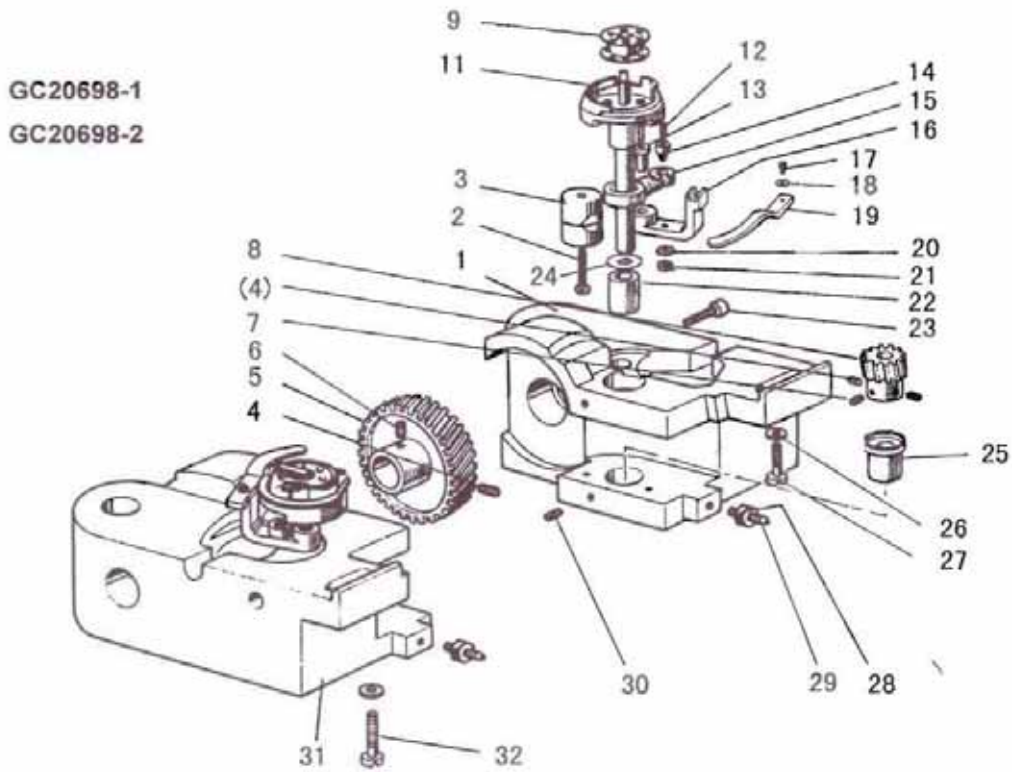



## H.HOOK SADDLE MECHANISM

Fig. No.	Part No.	Description	4400 LA-25	4420 LA-25	4400 LA-25 D1	4420 LA-25 D1	Remarks
H01	H700518001	Hook saddle (right)	1	1			
H01	H490618001	Hook saddle (right)			1	1	
H02	H320710661	Screw	1	2	1	2	SM15/64 (28) ×22
H03	H320710662	Bushing	1	2	1	2	
H04	H470718001	Screw	3	6	3	6	SM1/4 (40) ×4
H05	H470618001	Hook driving gear (large)	1	2	1	2	
H06	H470818001	Screw	1	2	1	2	SM1/4 (40) ×6.5
H07	H470918001	Screw	1	2	1	2	SM1/4 (40) ×5
H08	H470518001	Hook driving gear (small)	1	2	1	2	
H09	H330610067	Bobbin	1	2			
H09	H491218001	Bobbin			1	2	BO-B872(A)
H10	H492218001	Spring			1	2	
H11	H490817101	Hook complete			1	2	
H11	H470817101	Hook complete	1	2			
H12	H320410656	Oil wick	2	4	2	4	
H13	H321531504	Opener bracket shaft	1	2	1	2	
H14	H321531204	Screw	1	2	1	2	SM3/16 (32) ×7.8
H15	H331311204	Link	1	2	1	2	
H16	H331311104	Opener bracket	1	2	1	2	
H17	H200410067	Screw	1	2	1	2	
H18	H320012030	Washer	1	2	1	2	
H19	H330510066	Opener	1	2	1	2	
H20	H005008050	Spring washer	1	2	1	2	
H21	HA104G0658	Nut	1	2	1	2	
H22	H700618001	Hook shaft bushing (upper)	1	2			
H22	H490918001	Hook shaft bushing (upper)			1	2	
H23	H320410657	Screw	1	2	1	2	SM3/16 (28) ×14.5
H24	H331211204	Washer	1	2			
H24	H491018001	Washer			1	2	
H25	H320410653	Hook shaft bushing (lower)	1	2			
H25	H491118001	Hook shaft bushing (lower)			1	2	
H26	H201310065	Washer	1	2	1	2	
H27	H320012050	Screw	1	1	1	1	SM1/4 (24) ×23
H28	H320410659	Nut	1	2			
H28	H491418001	Nut			1	2	
H29	H320410658	Screw	1	2			
H29	H491518001	Screw			1	2	
H30	HA305E0662	Screw			2	4	
H31	H491718001	Hook saddle (left)				1	
H31	H700418001	Hook saddle (left)		1			
H32	H320012050	Screw	1	2			SM1/4 (24) ×23
H32	H491318001	Screw			1	2	SM1/4 (24) ×30

# I. THREAD TRIMMER MECHANISM

---

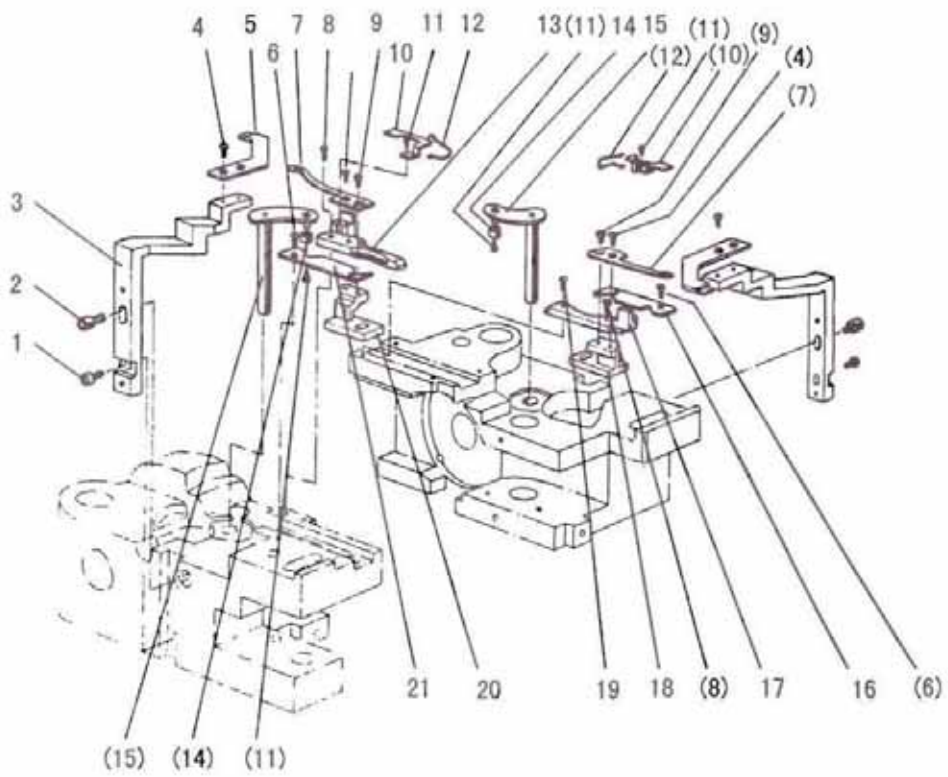

## I.THREAD TRIMMER MECHANISM

Fig. No.	Part No.	Description	4400 LA-25	4420 LA-25	4400 LA-25 D1	4420 LA-25 D1	Remarks
I01	H4905J8001	Screw			1	2	
I02	H4906J8001	Bolt			1	2	SM11/64 (40) ×12
I03	H4907J8001	Trimming knife holder			1	2	
I04	H4908J8001	Screw			3	6	SM9/64 (40) ×4
I05	H4909J8001	Fixed blade			1	2	
I06	H4914B8001	Screw			2	4	SM9/64 (40) ×4
I07	H4911J8001	Moved knife			1	2	
I08	H4912J8001	Screw			1	2	SM1/8 (44) ×9.2
I09	H4913J8001	Screw			1	2	SM9/64 (40) ×4.5
I10	H4914J8001	Spring plate			1	2	
I11	H4915J8001	Screw			3	6	SM3/32 (56) ×3.8
I12	H4916J8001	Reversing spring			1	2	
I13	H4917J8001	Guide			1	1	
I14	H4920J8001	Roller			1	2	
I15	H4921J8001	Lever			1	2	
I16	H4922J8001	Cover			1	1	
I17	H4923J8001	Guide (right)			1	1	
I18	H4924J8001	Knife pad (right)			1	1	
I19	H4925J8001	Screw			1	1	SM9/64 (40) ×9.5
I20	H4926J8001	Knife pad (left)			1	1	
I21	H4927J8001	Cover			1	1	

# J.THREAD TRIMMER MECHANISM

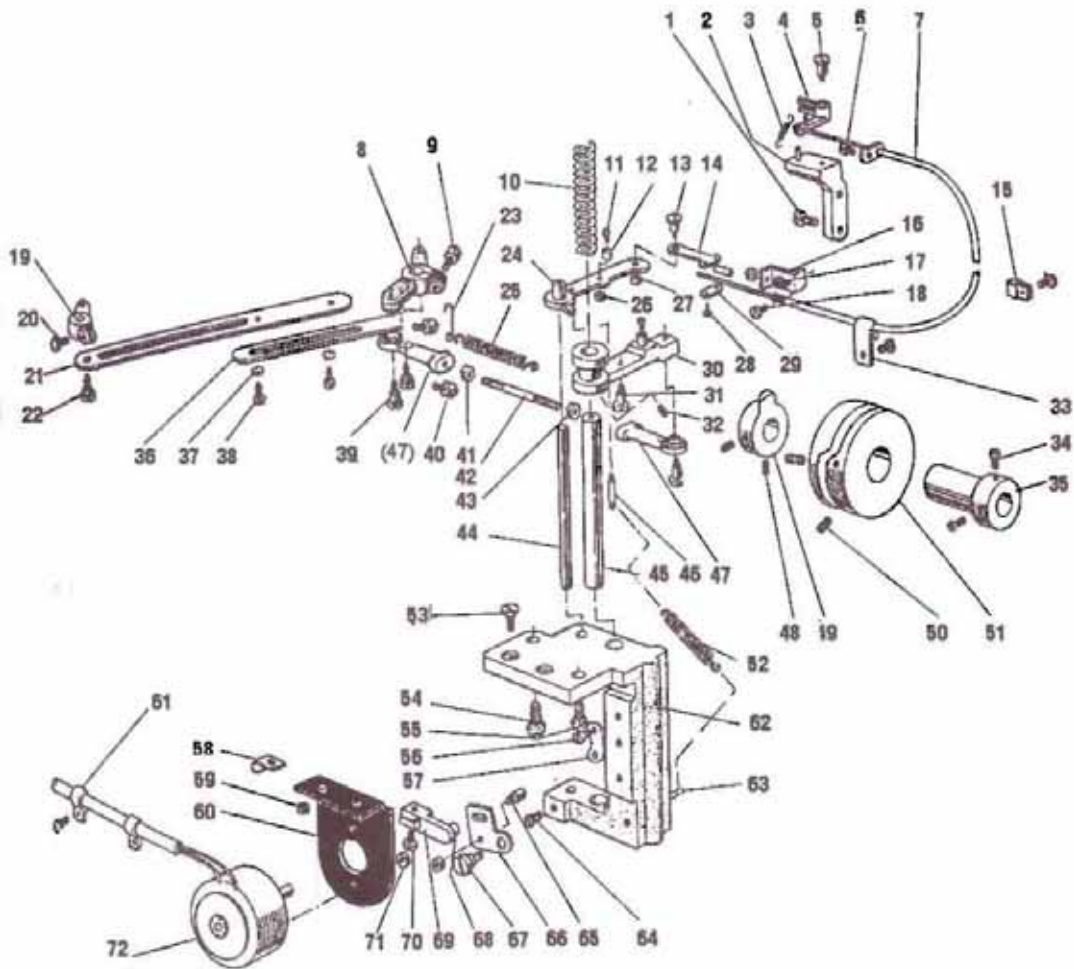

## J.THREAD TRIMMER MECHANISM

Fig. No.	Part No.	Description	4400 LA-25	4420 LA-25	4400 LA-25 D1	4420 LA-25 D1	Remarks
J01	HA300C2020	Screw			2	2	SM11/64 (40) ×8
J02	H4915K7101	Thread releading bracket			1	1	
J03	H4918K8001	Spring			1	1	
J04	H4919K7101	Thread releading plate			1	1	
J05	H2400I2040	Screw			1	1	SM11/64 (40) ×5
J06	HA300B2170	Screw			4	4	SM11/64 (40) ×8
J07	H0604K7101	Flexible wire complete			1	1	
J08	H4912K8001	Arm			1	1	
J09	H4913K8001	Bolt			1	1	SM15/64 (28) ×12.5
J10	H4945K8001	Spring			1	1	
J11	H4950K8001	Screw			1	1	SM11/64 (40) ×3.6
J12	H4949K8001	Roller			1	1	
J13	H4952K8001	Screw			1	1	SM3/16 (28) ×5
J14	H4953K8001	Mounting plate			1	1	
J15	HA700Q0030	Nylon clip			1	1	
J16	H4925K8001	Mounting plate			1	1	
J17	H003002050	Nut			2	2	GB/T6170 M5
J18	HA300C2030	Screw			1	1	SM11/64 (40) ×7
J19	H4908K8001	Arm				1	
J20	H4907K8001	Bolt				1	SM15/64 (28) ×12.5
J21	H4906K8001	Link				1	
J22	H4905K8001	Screw			2	2	M5 (0.5) ×7.5
J23	HA100H2080	Pin type			1	1	
J24	H4946K7101	Thread releasing lever			1	1	
J25	H4943K8001	Spring			1	1	
J26	H4951K8001	Nut			1	1	SM11/64 (40)
J27	H4954K8001	Nut			1	1	SM3/16 (28)
J28	H4956K8001	Screw			2	2	SM1/8 (44) ×7
J29	H4955K8001	Bushing			1	1	
J30	H4957K7101	Vibrating crank			1	1	
J31	H4944K8001	Screw			1	1	SM11/64 (40) ×5.5
J32	H4962K8001	Screw			2	2	M5×5
J33	HA708P0668	Nylon clip			1	1	
J34	HA113F0684	Screw			2	2	SM15/64 (28) ×8.5
J35	H4931K8001	Bushing			1	1	
J36	H4909K8001	Link				1	
J37	H005001050	Washer				1	GB/T97.1 5
J38	H4911K8001	Bolt				2	
J39	H4936K8001	Screw			2	2	M5 (0.5) ×8.5
J40	H4987K8001	Bolt			1	1	
J41	H4940K8001	Nut (left)			1	1	M5
J42	H4939K8001	Bolt			1	1	
J43	H003002050	Nut (right)			1	1	GB/T6170 M5

## J.THREAD TRIMMER MECHANISM

Fig. No.	Part No.	Description	4400 LA-25	4420 LA-25	4400 LA-25 DI	4420 LA-25 DI	Remarks
J44	H4964K8001	Shaft			1	1	
J45	H4963K8001	Shaft			1	1	
J46	H4985K8001	Screw			1	1	SM11/64 (40) ×4
J47	H3405D0663	Ball joint (right)			2	2	
J48	H3205G1114	Screw			4	4	M4×4
J49	H4934K8001	Cam			1	1	
J50	HA710E0692	Screw			2	2	SM1/4 (40) ×9.5
J51	H4932K8001	Cam			1	1	
J52	H4986K8001	Spring			1	1	
J53	H411050160	Screw			2	2	GB/T819.1 M5×16
J54	H2012N0652	Screw			1	1	SM1/4 (24) ×16
J55	H4983K8001	Screw			1	1	SM1/4 (24) ×13
J56	H4967K8001	Screw			3	3	SM11/64 (40) ×7
J57	H4966K8001	Stopper			1	1	
J58	H4981K8001	Holder			1	1	
J59	H003008050	Nut			2	2	GB/T6172.1 M5
J60	H4977K8001	Mounting plate			1	1	
J61	H4980K8001	Holder			2	2	
J62	H4965K8001	Set plate			1	1	
J63	H3700E2080	Pin type			1	1	
J64	H4969K8001	Screw			1	1	SM11/64 (40) ×8.5
J65	H4970K8001	Screw			1	1	SM11/64 (40) ×6
J66	H4971K8001	Lever			1	1	
J67	H4972K8001	Screw			1	1	SM11/64 (40) ×6.8
J68	H4973K8001	Pin			1	1	
J69	H4974K8001	Arm			1	1	
J70	HA111G0683	Screw			1	1	SM11/64 (40) ×12
J71	HA7111N304	Nut			1	1	SM11/64 (40)
J72	H4979K8004	Solenoid complete			1	1	

## K.TOUCH BACK AND DETECTOR MECHANISM

---

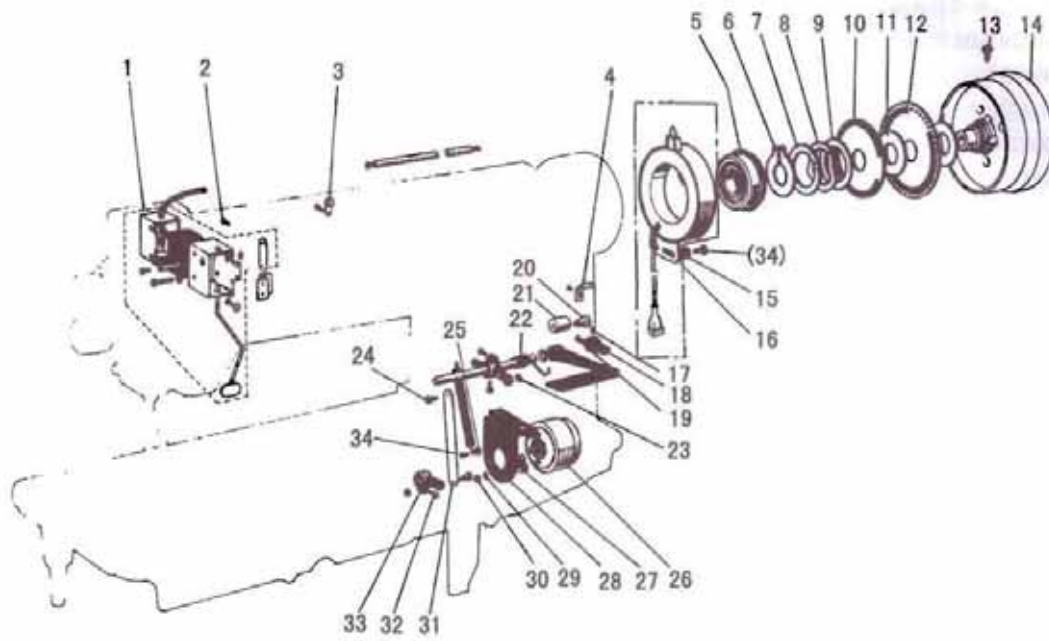

## K.TOUCH BACK AND DETECTOR MECHANISM

Fig. No.	Part No.	Description	4400 LA-25	4420 LA-25	4400 LA-25 D1	4420 LA-25 D1	Remarks
K01	H4905L7101	Touth switch complete			1	1	
K02	H4918L8001	Screw			4	4	M5
K03	HA700Q0030	Holder			2	2	
K04	H4922L8001	Holder			1	1	
K05	H3205J0662	Ball bearing			1	1	
K06	H007009300	Retaining ring C-type			1	1	GB/T894.1 30
K07	HA700R0060	Washer			1	1	
K08	HA700R0050	Support spring			1	1	
K09	HA700R0040	Spacer B			1	1	
K10	H4928L8001	Speed command disk F20 (up)			1	1	
K11	HA700R0030	Spacer A			2	2	
K12	H4930L8001	Speed command disk F11 (down)			1	1	
K13	HA110D0672	Screw			2	2	SM15/64 (28) ×12
K14	H4931L8001	Pulley (complete)			1	1	
K15	HA703R0067	Washer			1	1	
K16	HA703R0065	Detector bracket (complete)			1	1	
K17	HA3411D308	Screw			1	1	SM15/64 (28) ×7
K18	H4936L8001	Lever			1	1	
K19	HA113F0684	Screw			1	1	SM15/64 (28) ×7.5
K20	H4937L8001	Screw			1	1	SM15/64 (28) ×6
K21	H4938L8001	Rubber ring			1	1	
K22	H4939L8001	Spring			1	1	
K23	H4940L8001	Nut			2	2	
K24	H4941L8001	Screw			2	2	SM15/64 (28) ×14
K25	H4942L8001	Nut			1	1	
K26	H4943L8001	Solenoid (complete)			1	1	
K27	H102080120	Blot			2	2	GB/T5781 M8×12
K28	H4945L8001	Set plate			1	1	
K29	H005008060	Spring washer			2	2	GB/T93 6
K30	H003002060	Nut			2	2	GB/T6170 M6
K31	H4948L8001	Link			1	1	
K32	H4949L8001	Blot			1	1	SM15/64 (28) ×13
K33	H4950L8001	Arm			1	1	
K34	HA300C2030	Screw			2	2	SM11/64 (40) ×8



# L.ACCESSORIES

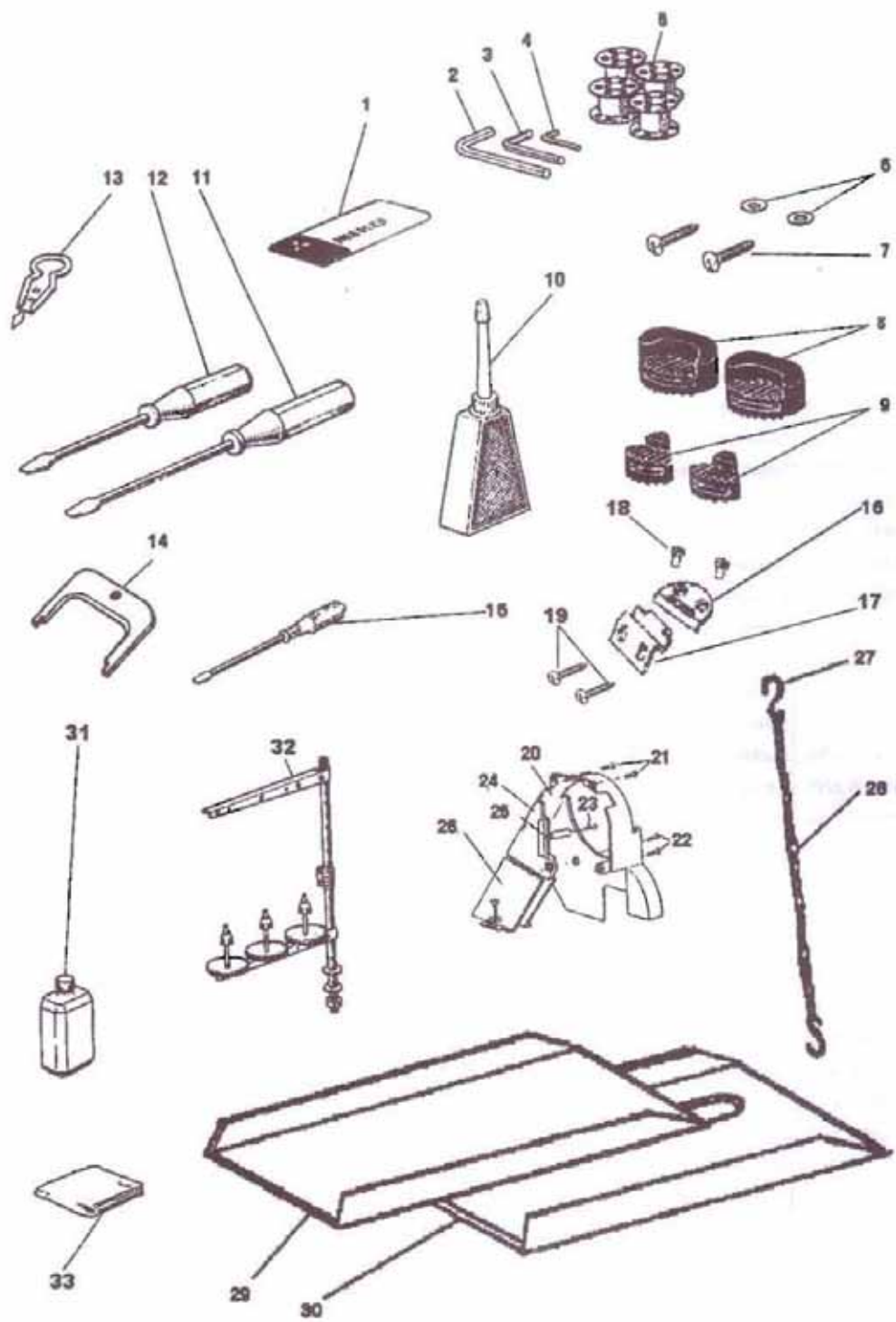







## L.ACCESSORIES

Fig. No.	Part No.	Description	4400 LA-25	4420 LA-25	4400 LA-25 D1	4420 LA-25 D1	Remarks
L01	H4740F8001	Needle DP×17-23	3	6	3	6	
L02	H3209L8001	Socket wrench			1	1	
L03	H3208L8001	Socket wrench	1	1	1	1	
L04	H4905N8001	Socket wrench			1	1	
L05	H3306I0067	Bobbin	2	4			
L05	H4912I8001	Bobbin			2	4	B0-B872 (A)
L06	H3200L0050	Washer	2	2	2	2	
L07	H801045200	Screw	4	4	4	4	GB/T99 4.5×20
L08	H4700K0020	Vibration preventing rubber	2	2	2	2	
L09	H4700K0030	Vibration preventing rubber	2	2	2	2	
L10	HA100J2110	Oiler	1	1	1	1	
L11	HA100J2140	Screw driver (middle)	1	1	1	1	
L12	HA100J2150	Screw driver (small)	1	1	1	1	
L13	H3207L0065	Thread a needle kit	1	1	1	1	
L14	HA704S0654	Adjusting plate for speed command disk			1	1	
L15	HA300J2070	Screw driver (large)	1	1	1	1	
L16	H2404K0654	Hinge complete	2	2	2	2	
L17	H2404K0655	Hinge complete	2	2	2	2	
L18	H2404K0656	Screw	4	4	4	4	
L19	H802080350	Screw	4	4	4	4	GB/T100 8×35
L20	H2008O0068	Belt cover			1	1	
L21	HA300C2170	Screw			2	2	SM11/64 (40) ×8
L22	HA300J2280	Screw	2	2	2	2	SM11/64 (28) ×8
L23	HA300J2250	Screw			1	1	M4×8
L24	H2405B6601	Belt cover complete	1	1			
L24	H4708K7101	Belt cover complete			1	1	
L25	H003008040	Nut			1	1	GB/T6172.1 M4
L26	HA305J0665	Belt cover	1	1	1	1	
L27	HPG100E202	Pothook	2	2	2	2	
L28	HPG100E203	Chain	1	1	1	1	
L29	H7013K8001	Oil check	1	1	1	1	
L30	H7014K8001	Oil check	1	1	1	1	
L31	I13200L0130	Oil box	1	1	1	1	
L32	HA300J2370	Cotton stand	1		1		
L32	I13200L0120	Knee lift shaft		1		1	
L33	H7009K8001	Vinyl cover	1	1	1	1	

## L.ACCESSORIES

Fig. No.	Part No.	Description	4400 LA-25	4420 LA-25	4400 LA-25 DI	4420 LA-25 DI	Remarks
L01	H4740F8001	Needle DP×17-23	3	6	3	6	
L02	H3209L8001	Socket wrench			1	1	
L03	H3208L8001	Socket wrench	1	1	1	1	
L04	H4905N8001	Socket wrench			1	1	
L05	H3306I0067	Bobbin	2	4			
L05	H4912I8001	Bobbin			2	4	B0-B872 (A)
L06	H3200L0050	Washer	2	2	2	2	
L07	H801045200	Screw	4	4	4	4	GB/T99 4.5×20
L08	H4700K0020	Vibration preventing rubber	2	2	2	2	
L09	H4700K0030	Vibration preventing rubber	2	2	2	2	
L10	HA100J2110	Oiler	1	1	1	1	
L11	HA100J2140	Screw driver (middle)	1	1	1	1	
L12	HA100J2150	Screw driver (small)	1	1	1	1	
L13	H3207L0065	Thread a needle kit	1	1	1	1	
L14	HA704S0654	Adjusting plate for speed command disk			1	1	
L15	HA300J2070	Screw driver (large)	1	1	1	1	
L16	H2404K0654	Hinge complete	2	2	2	2	
L17	H2404K0655	Hinge complete	2	2	2	2	
L18	H2404K0656	Screw	4	4	4	4	
L19	H802080350	Screw	4	4	4	4	GB/T100 8×35
L20	H2008O0068	Belt cover			1	1	
L21	HA300C2170	Screw			2	2	SM11/64 (40) ×8
L22	HA300J2280	Screw	2	2	2	2	SM11/64 (28) ×8
L23	HA300J2250	Screw			1	1	M4×8
L24	H2405B6601	Belt cover complete	1	1			
L24	H4708K7101	Belt cover complete			1	1	
L25	H003008040	Nut			1	1	GB/T6172.1 M4
L26	HA305J0665	Belt cover	1	1	1	1	
L27	HPG100E202	Pothook	2	2	2	2	
L28	HPG100E203	Chain	1	1	1	1	
L29	H7013K8001	Oil check	1	1	1	1	
L30	H7014K8001	Oil check	1	1	1	1	
L31	I13200L0130	Oil box	1	1	1	1	
L32	HA300J2370	Cotton stand	1		1		
L32	I13200L0120	Knee lift shaft		1		1	
L33	H7009K8001	Vinyl cover	1	1	1	1	

### Gauge Parts List

							
Gauge size	Needle plate	Presser Foot (inside)	Presser Foot (outside)	Needle clamp	Feed Dog	Slide plate (L)	Slide plate (R)
4420 LA-25							
1/8 (3.2mm)	H4737B8001	H4741F8001	H4758E8001	H4750F8001	H4745H8001	H4732B8001	H4733B8001
5/32 (4mm)	H4738B8001	H4742F8001	H4759E8001	H4751F8001	H4746H8001	H4732B8001	H4733B8001
3/16 (4.8mm)	H4739B8001	H4743F8001	H4760E8001	H4752F8001	H4747H8001	H4732B8001	H4733B8001
1/4 (6.4mm)	H4734B8001	H4737F8001	H4757E8001	H4739F8001	H4744H8001	H4732B8001	H4733B8001
5/16 (8mm)	H4740B8001	H4744F8001	H4761E8001	H4753F8001	H4748H8001	H4746B8001	H4733B8001
3/8 (9.5mm)	H4741B8001	H4745F8001	H4762E8001	H4754F8001	H4749H8001	H4746B8001	H4733B8001
1/2 (12.7mm)	H4742B8001	H4746F8001	H4763E8001	H4755F8001	H4750H8001	H4747B8001	H4750B8001
5/8 (16mm)	H4743B8001	H4747F8001	H4764E8001	H4756F8001	H4751H8001	H4747B8001	H4750B8001
3/4 (19mm)	H4744B8001	H4748F8001	H4765E8001	H4757F8001	H4752H8001	H4748B8001	H4750B8001
1 (25.4mm)	H4745B8001	H4749F8001	H4766E8001	H4758F8001	H4753H8001	H4749B8001	H4750B8001
4420 LA-25 D1							
1/8 (3.2mm)	H4937B8001	H4741F8001	H4758E8001	H4750F8001	H4945H8001	H4732B8001	H4733B8001
5/32 (4mm)	H4938B8001	H4742F8001	H4759E8001	H4751F8001	H4946H8001	H4732B8001	H4733B8001
3/16 (4.8mm)	H4939B8001	H4743F8001	H4760E8001	H4752F8001	H4947H8001	H4732B8001	H4733B8001
1/4 (6.4mm)	H4917B8001	H4737F8001	H4757E8001	H4739F8001	H4944H8001	H4732B8001	H4733B8001
5/16 (8mm)	H4940B8001	H4744F8001	H4761E8001	H4753F8001	H4948H8001	H4746B8001	H4733B8001
3/8 (9.5mm)	H4941B8001	H4745F8001	H4762E8001	H4754F8001	H4949H8001	H4746B8001	H4733B8001
1/2 (12.7mm)	H4942B8001	H4746F8001	H4763E8001	H4755F8001	H4950H8001	H4747B8001	H4733B8001
5/8 (16mm)	H4943B8001	H4747F8001	H4764E8001	H4756F8001	H4951H8001	H4747B8001	H4733B8001
3/4 (19mm)	H4944B8001	H4748F8001	H4765E8001	H4757F8001	H4952H8001	H4748B8001	H4750B8001
1 (25.4mm)	H4945B8001	H4749F8001	H4766E8001	H4758F8001	H4953H8001	H4749B8001	H4750B8001
4400 LA-25							
	H7806B8001	H4807F8001	H3100G2110		H4807H8001	H4812B8001	H4813B8001
4420 LA-25 D1							
	H5014B8001	H4807F8001	H3100G2110		H5004H8001	H4812B8001	H4813B8001