

ARTISAN®

Model 335 B

Cylinder Bed Walking
Foot Sewing Machine



Operators Manual
and
Spare Parts Booklet

Index for ARTISAN® model 335 B

Contents	Page
Adjustment.....	1
Notes on adjustment	1
Tools, gauges and other accessories for adjusting	1
Abbreviations	1
Explanation of the symbols.....	1
Adjusting the basic machine	2
Lateral positioning of the feed dog	2
Lengthwise positioning of the feed dog	3
Height of the bottom feed dog (only on machines with lifting phase – P-version)	4
Centering the needle in the needle hole.....	5
Pre-adjusting the needle height	6
Driving motion of the top and bottom feed dogs	7
Lifting motion of the bottom feed dog (only on machines with lifting phase – P-version)....	8
Needle rise, hook-to-needle clearance and needle height	9
Vibrating presser lift	10
Vibrating presser feeding motion	11
Needle thread tension release	12
Thread check spring	13
Regulating the pressure on the presser foot	14

Index

	Contents	Page
13.06	Parameter settings (only on machines with Quick-EcoDrive and control unit P40ED).....	31
13.06.01	Parameter list.....	31
14	Circuit diagrams.....	32

Step 1



The thread stand and thread guide need to be parallel to each other for the correct tension to be maintained. The thread will move off the spool to the back of the guide feeding from back to front.

Step 2



The thread will go thru the top hole then around the pin passing thru the bottom hole as shown in image above.

Step 3



Fig 6-1

The thread then passes thru the bottom tension guide opening as illustrated above.

Step 4



Fig 7-1

1. Start from tension post to lower guide opening
2. Through lower opening under rod
3. Over and around ,pulled into top tension screw guide
4. Down and around lower tension guide
5. Over rod
6. Under and around lowest tension guide
7. Around guide all the way up past inter thread hook
8. Up through thread guide upper

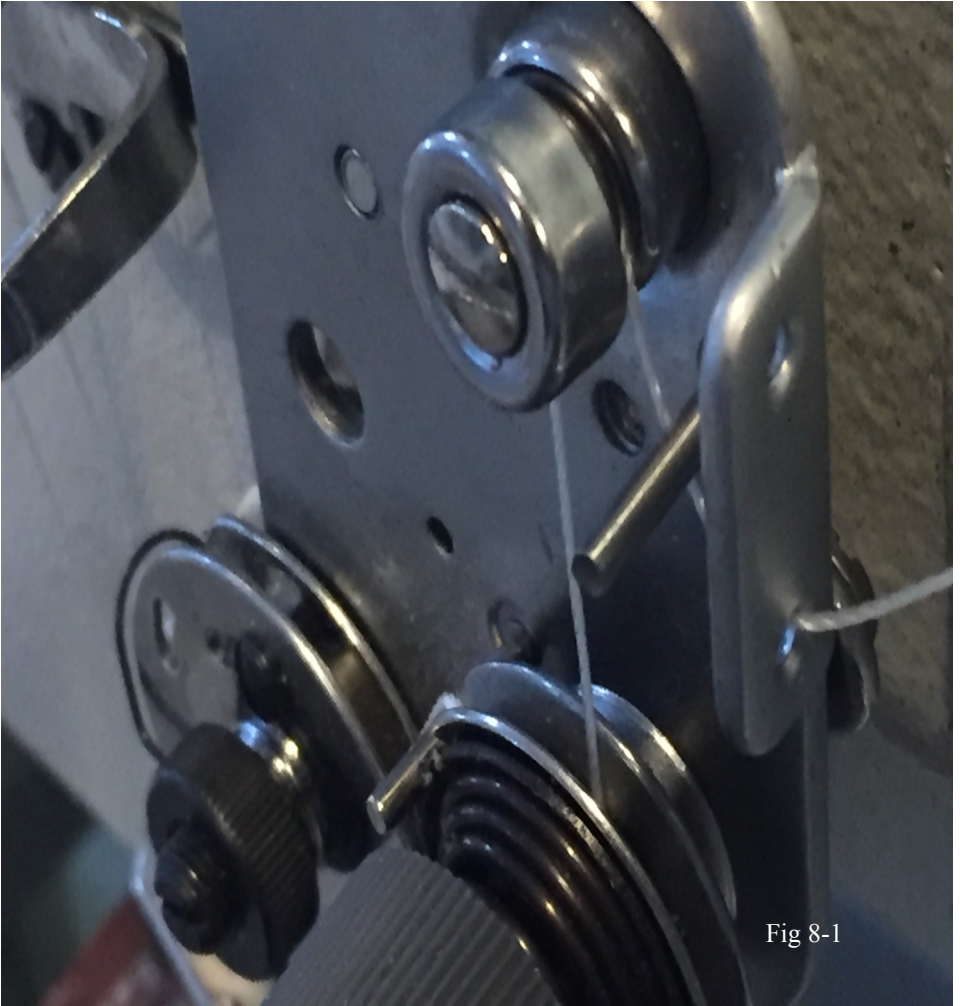

Closer view of operation 1, 2, and 3 from previous page 7

Closer view of operation 4, 5, 6, 7, and 8 from previous page 7

1. Around guide all the way up past inter thread hook. Pulling thread all the way into guide groove.



Fig 9-1

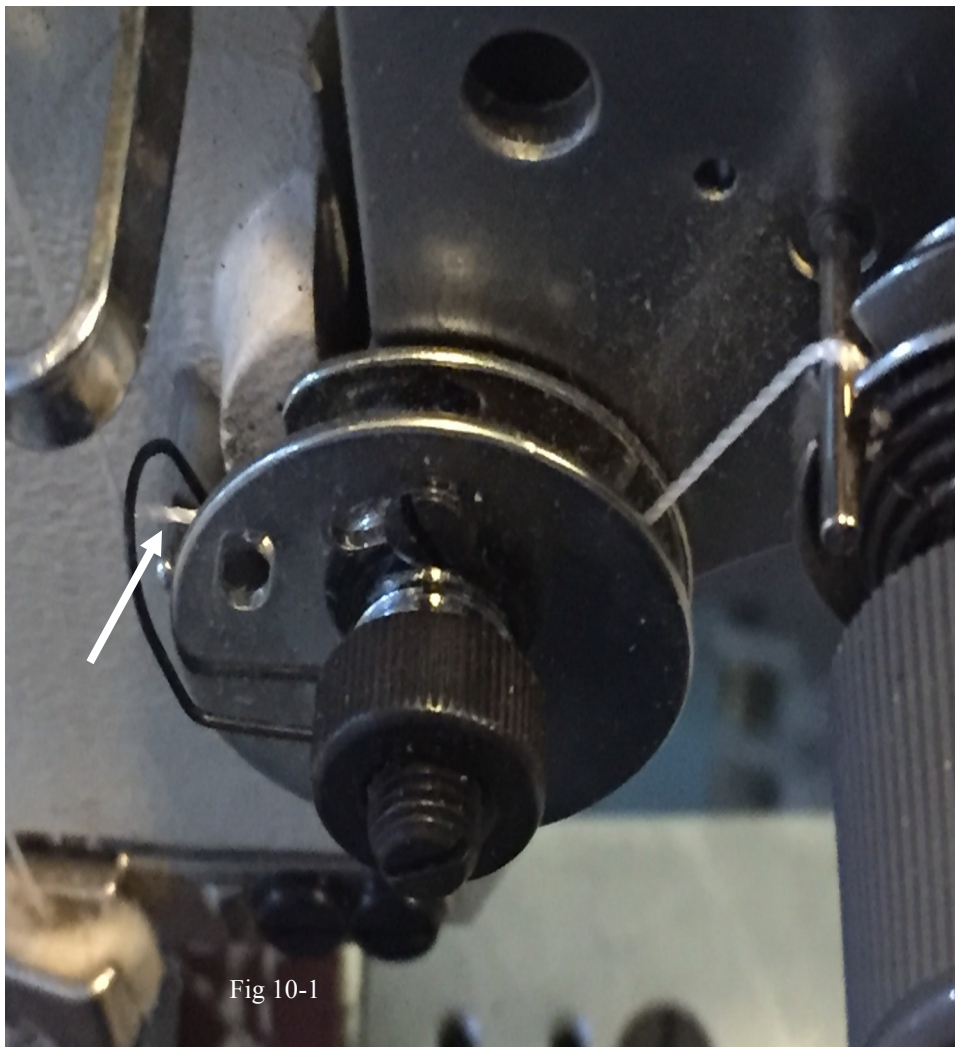

Fig 10-1

Another view of lower guide retainer



Fig 11-1

Another view of lower guide retainer

Step 5



Up through and to thread take-up libra

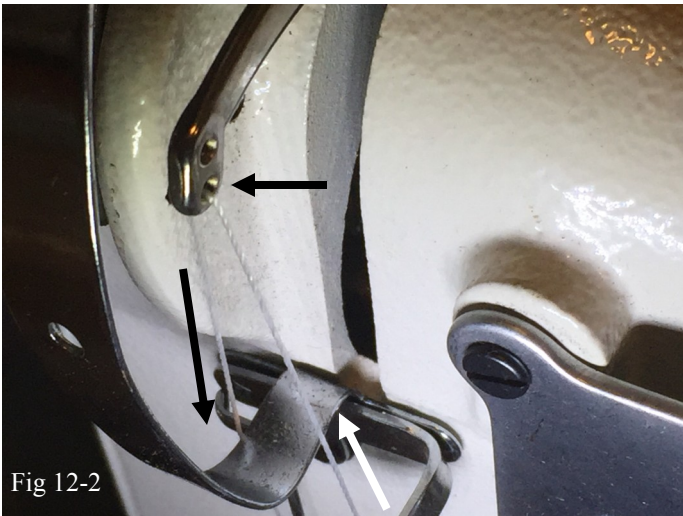

Through lower opening on thread take-up libra. Down past the left side of the libra cover.

Step 6

Artisan 335B



Fig 13-1

Down through felted thread guide

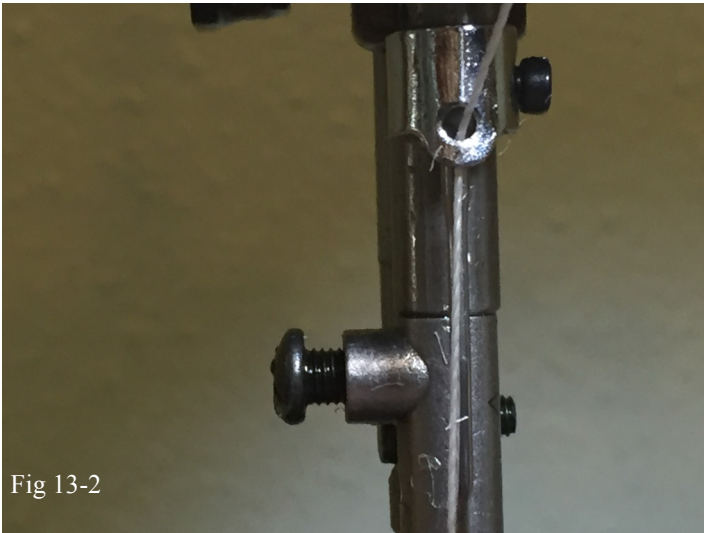

Fig 13-2

Passing through eyelet on the upper part of the center press shaft.

Step 7



Fig 14-1

Finally down the left side of the needle passing through from left to right the eye of the needle.

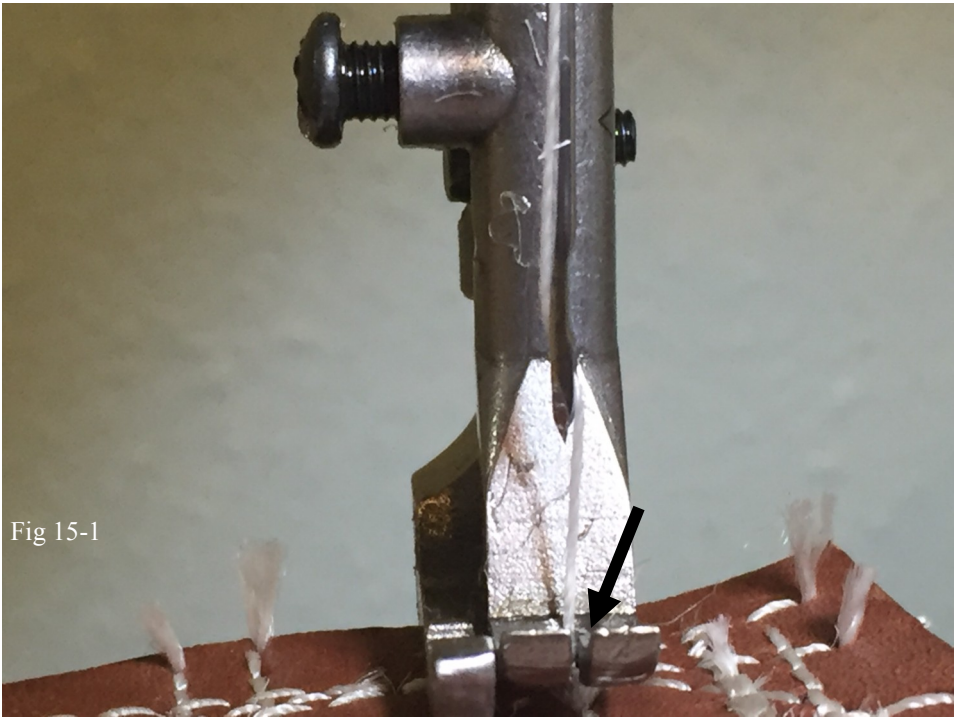

Fig 15-1

Pulling thread down thru center opening
and to the rear of the presser foot

13 Adjustment



Please observe all notes from Chapter 1 **Safety** of the instruction manual!
In particular care must be taken to see that all protective devices are refitted properly after adjustment, see Chapter 1.06 **Danger warnings** of the instruction manual!



If not otherwise stated, the machine must be disconnected from the electrical power supply. Danger of injury due to unintentional starting of the machine!

13.01 Notes on adjustment

All following adjustments are based on a fully assembled machine and may only be carried out by expert staff trained for this purpose.

Machine covers, which have to be removed and replaced to carry out checks and adjustments, are not mentioned in the text.

The order of the following chapters corresponds to the most logical work sequence for machines which have to be completely adjusted. If only specific individual work steps are carried out, both the preceding and following chapters must be observed.

Screws, nuts indicated in brackets () are fastenings for machine parts, which must be loosened before adjustment and tightened again afterwards.

13.02 Tools, gauges and other accessories for adjusting

- Screwdrivers with blade width from 2 to 10 mm
- Spanners (wrenches) with jaw width from 7 to 14 mm
- Allan keys from 2 to 6 mm
- Metal rule (part No. 08-880 218-00)
- Needle-rise gauge (part No. 61-111 600-01)
- Gauge, (top feed stroke 7 mm) (Part No. 61-111 633-61)
- Screw clamp (part No. 61-111 600-35)

13.03 Abbreviations

t.d.c. = top dead centre

b.d.c. = bottom dead centre

13.04 Explanation of the symbols

In this adjustment manual, symbols emphasize operations to be carried out or important information. The symbols used have the following meaning:



Note, information

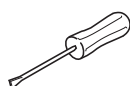

Service, repair, adjustment, maintenance
(work to be carried out by qualified staff only)

Adjustment

13.01 Adjusting the basic machine

13.04.01 Lateral positioning of the feed dog

Requirement

The clearances from the left and right of the bottom feed dog 1 to the needle plate cutout must be the the same size.

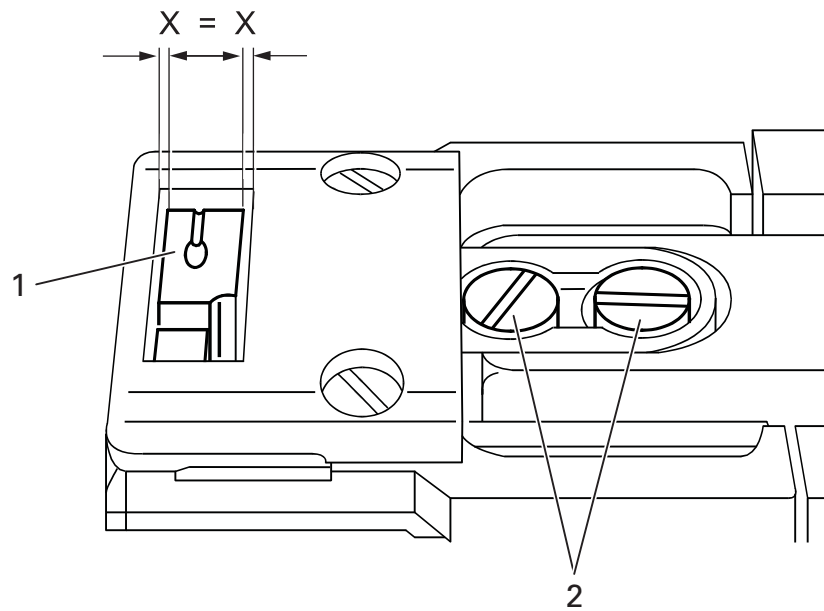
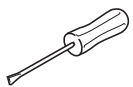

Fig. 13 - 01



- Move the bottom feed dog 1 (screws 2) in accordance with the requirement.

13.04.02 Lengthwise positioning of the feed dog

Requirement

With the stitch length set at its longest the clearances behind and in front of the bottom feed dog 4 to the needle plate cutout must be the same.

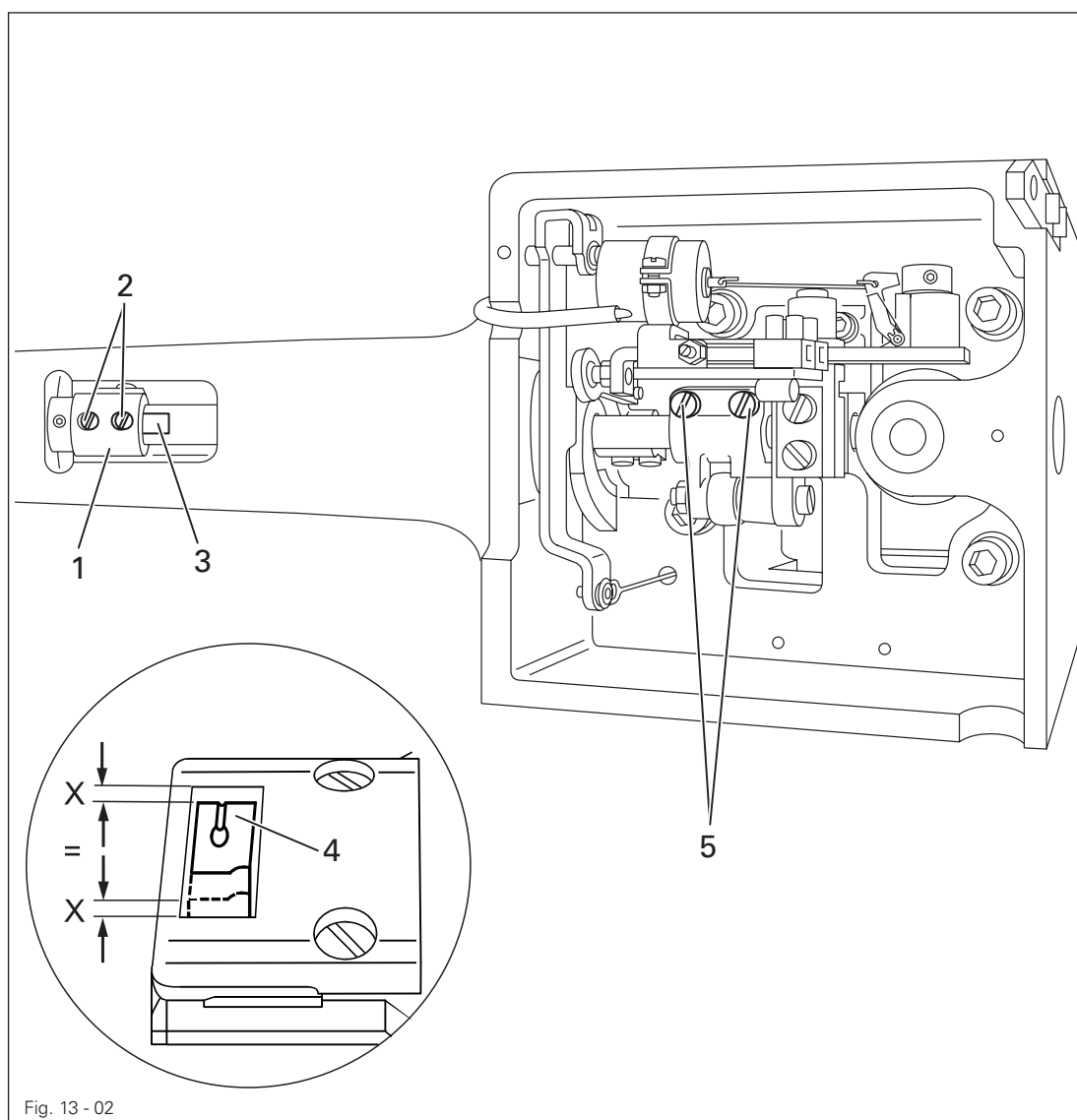
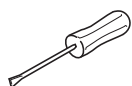

Fig. 13 - 02



- Set the longest stitch length.
- Move the clamp piece 1 (screws 2) as far to the left as possible on the clamp surface 3 of the rock shaft. The left screw must still be on the clamp surface.
- Position feed dog 4 (screws 5) according to **requirement**.

Adjustment

13.04.03 Height of the bottom feed dog (only on machines with lifting phase – P-version)

Requirement

When the stitch length is set at "0", in its highest position the bottom feed dog 4 should be 0.8 - 1.1 mm above the top edge of the needle plate.

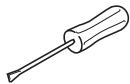
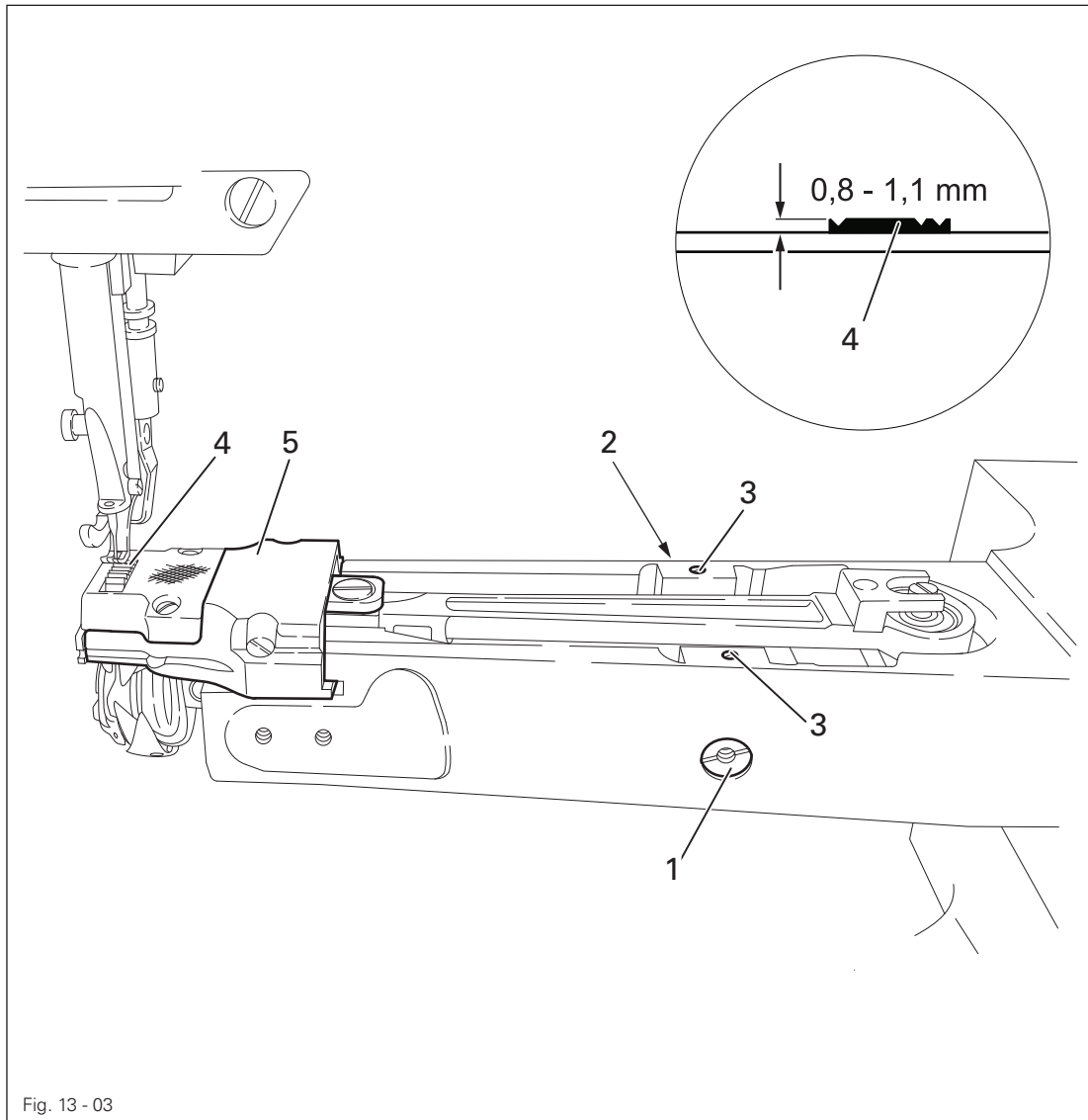

- Set the stitch length at "0".
- Adjust eccentric 1 and 2 (screws 3) in accordance with the requirement.



The bottom feed dog 4 should not touch cloth plate 5.

13.04.04 Centering the needle in the needle hole

Requirement

With the stitch length set at "0" the needle must enter the needle hole exactly in the middle.

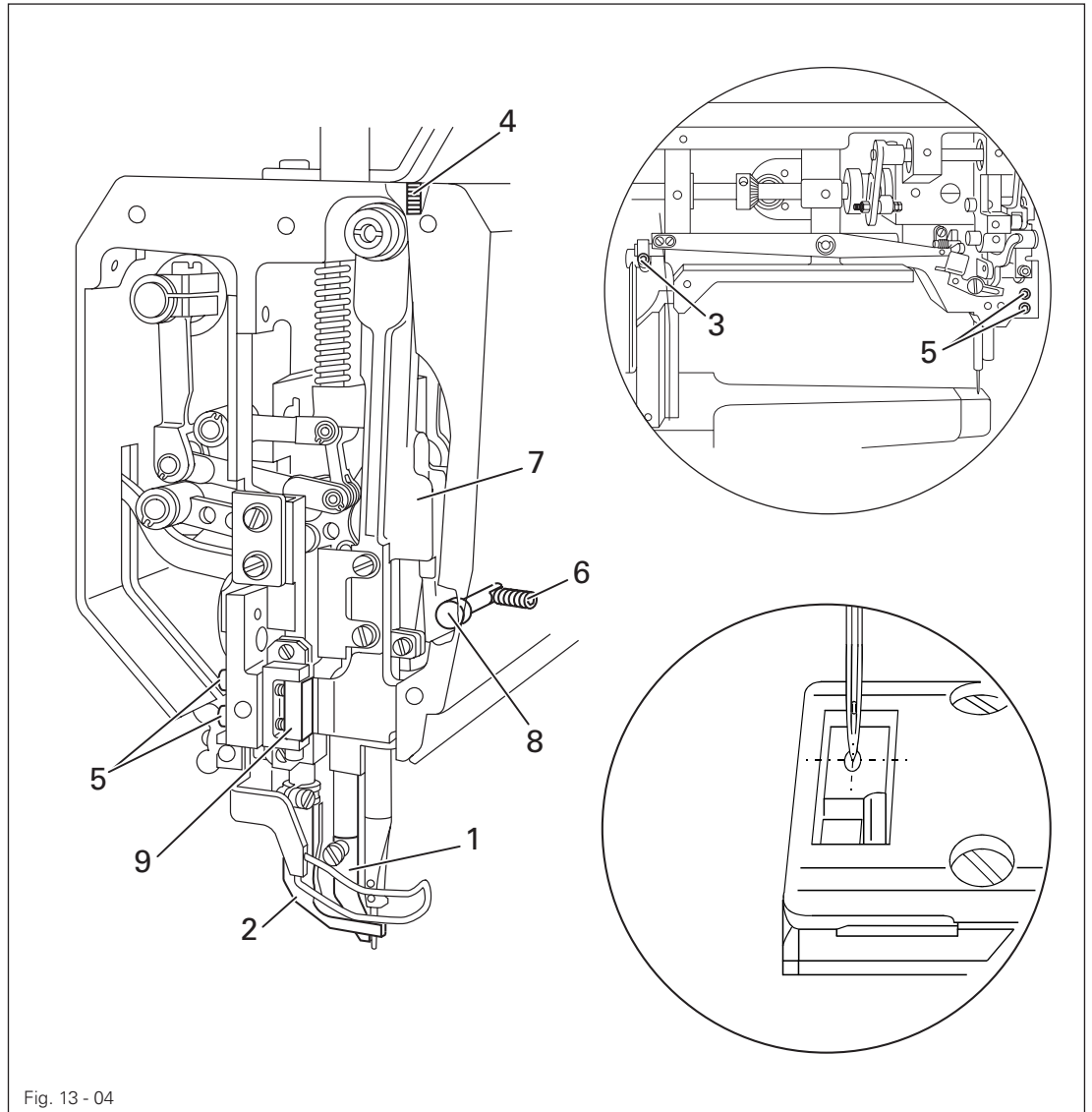
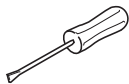

Fig. 13 - 04



- Unscrew the vibrating presser foot 1 and the presser foot 2.
- Set the stitch length at "0" and bring the needle to its tdc.
- Insert a new needle. Loosen screws 3, 4, 5 and 6.
- Bring the needle to a position directly over the bottom feed dog by turning the handwheel.
- Move the needle bar frame 7 in accordance with the **requirement**.
- Tighten screws 3, 4 and 5.
- Position stop 8 so that it is touching the needle bar frame 7 and tighten screw 6.



The needle bar frame 7 in guide 9 and the vibrating presser drive shaft must move freely.

Adjustment

13.04.05 Pre-adjusting the needle height

Requirement

With the needle bar at its bdc the distance between the needle bar and the needle plate must be **15 mm**.

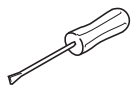
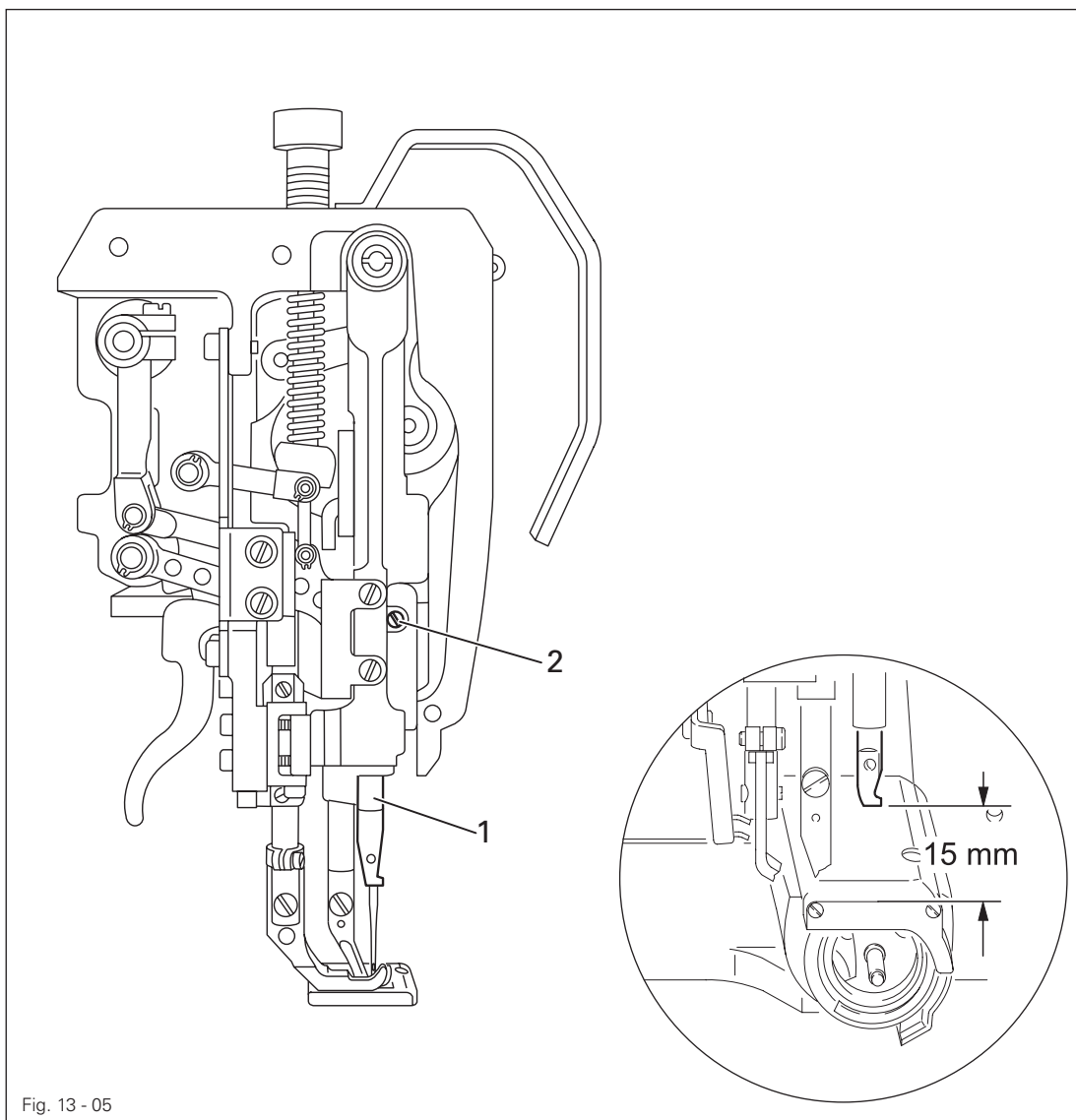

- Move the needle bar 1 (screw 2) in accordance with the **requirement** without twisting it.

13.04.06 Driving motion of the top and bottom feed dogs

Requirement

With the longest stitch length set and the needle bar at its bdc the top and bottom feed dogs should not move when the reverse feed lever is activated.

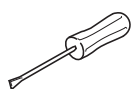
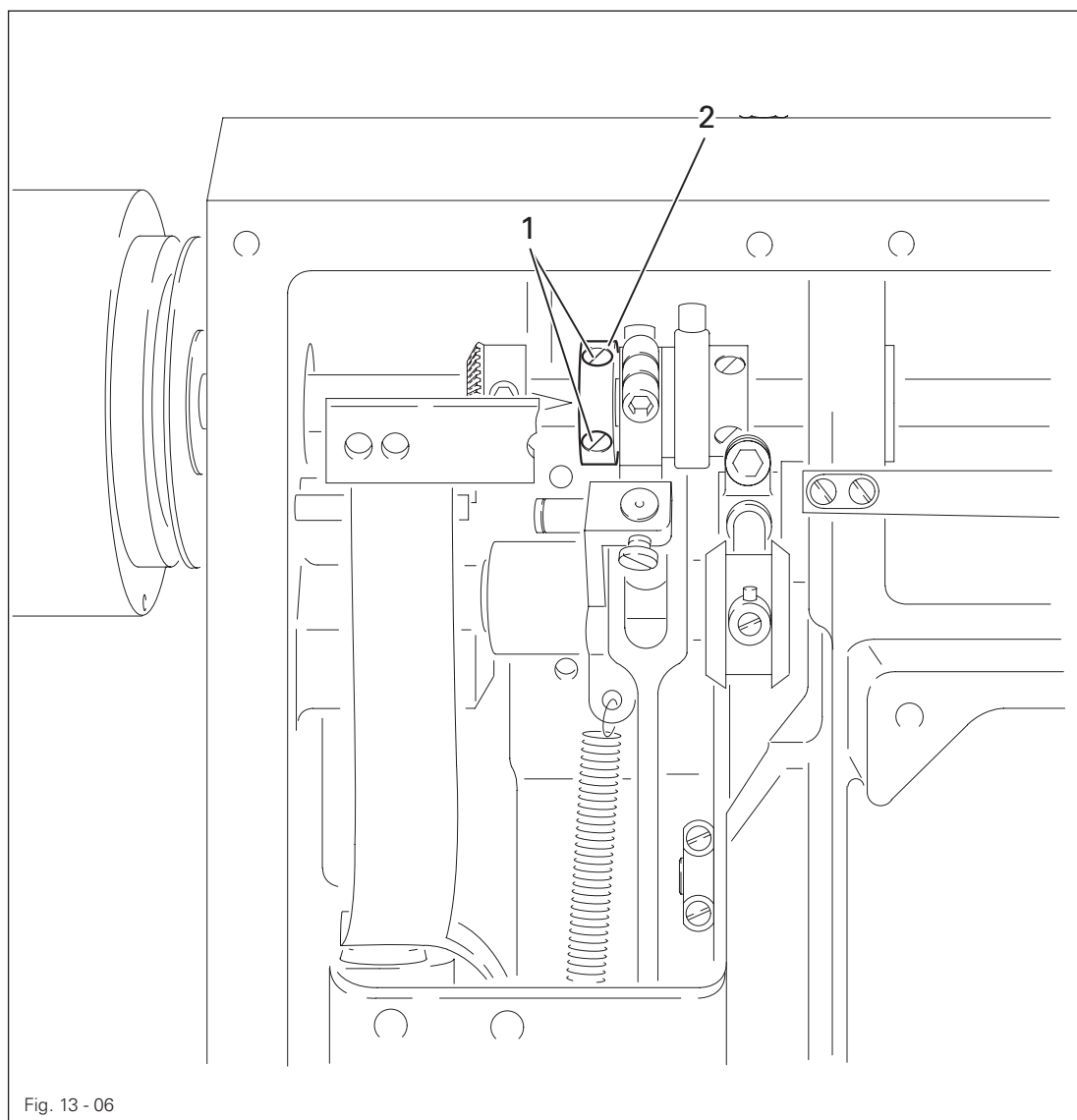

- Set the longest stitch length.
- Loosen screw 1 far enough so that the feed driving eccentric 2 can be turned on the shaft with some difficulty.
- Bring the needle to its bdc.
- While keeping this position, move the feed driving eccentric 2 to the top and then move it slightly so that the **requirement** is fulfilled when the reverse feed lever is activated.
- Tighten screws 1.

Adjustment

13.04.07 Lifting motion of the bottom feed dog (only on machines with lifting phase – P-version)

Requirement

1. With the needle bar positioned at b.d.c., the bottom feed dog should be in the t.d.c. position.
2. With the maximum stitch length set, when the balance wheel is turned the bottom feed dog should reach the needle plate surface at the same time as the needle point.

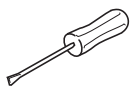
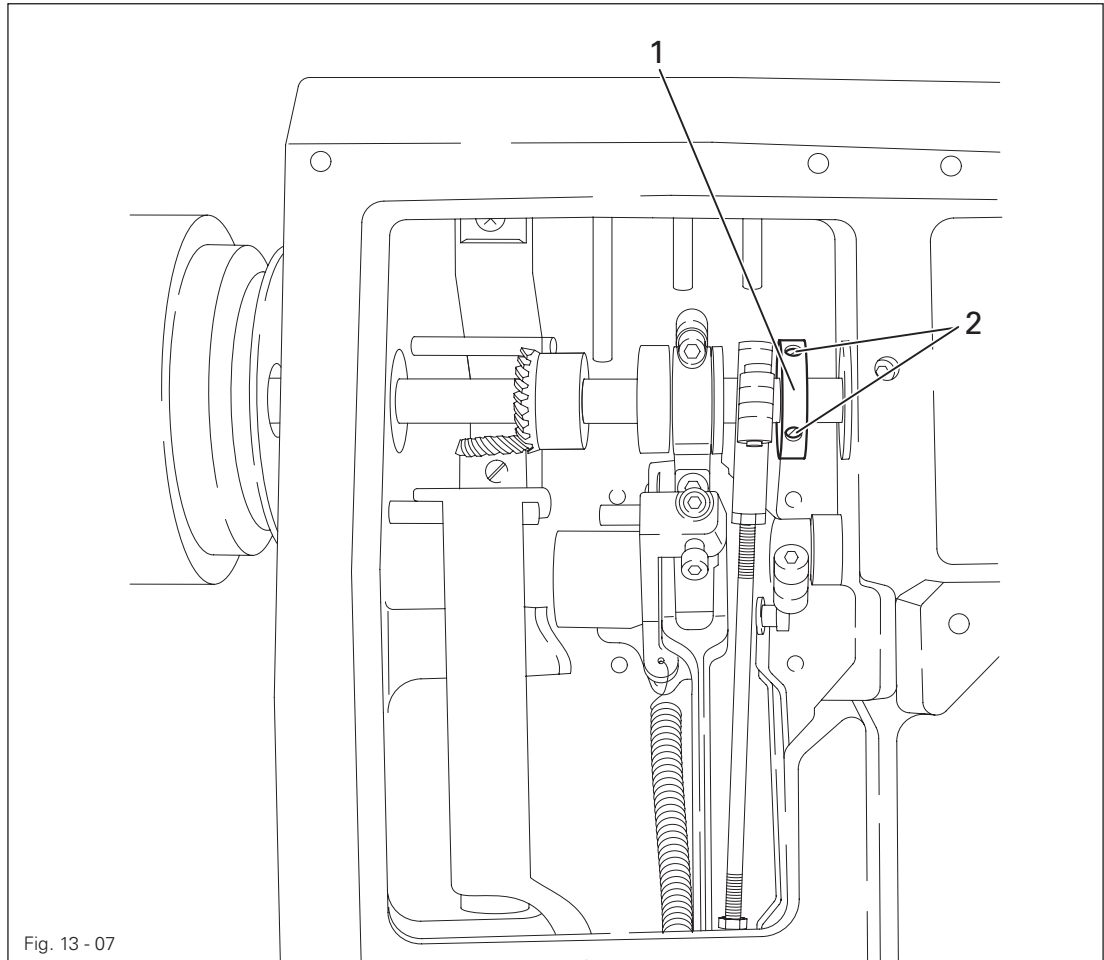

- Adjust eccentric 1 (screws 2) in accordance with the requirements.

13.04.08 Needle rise, hook-to-needle clearance and needle height

Requirement

With the stitch length set at "3" (1.8 mm after the bdc of the needle bar) the following must be correct:

1. The hook point must be opposite the middle of the needle and the distance to the needle must be **0.05 - 0.1 mm**.
2. The top edge of the needle eye must be **0.8 mm** from the hook point.

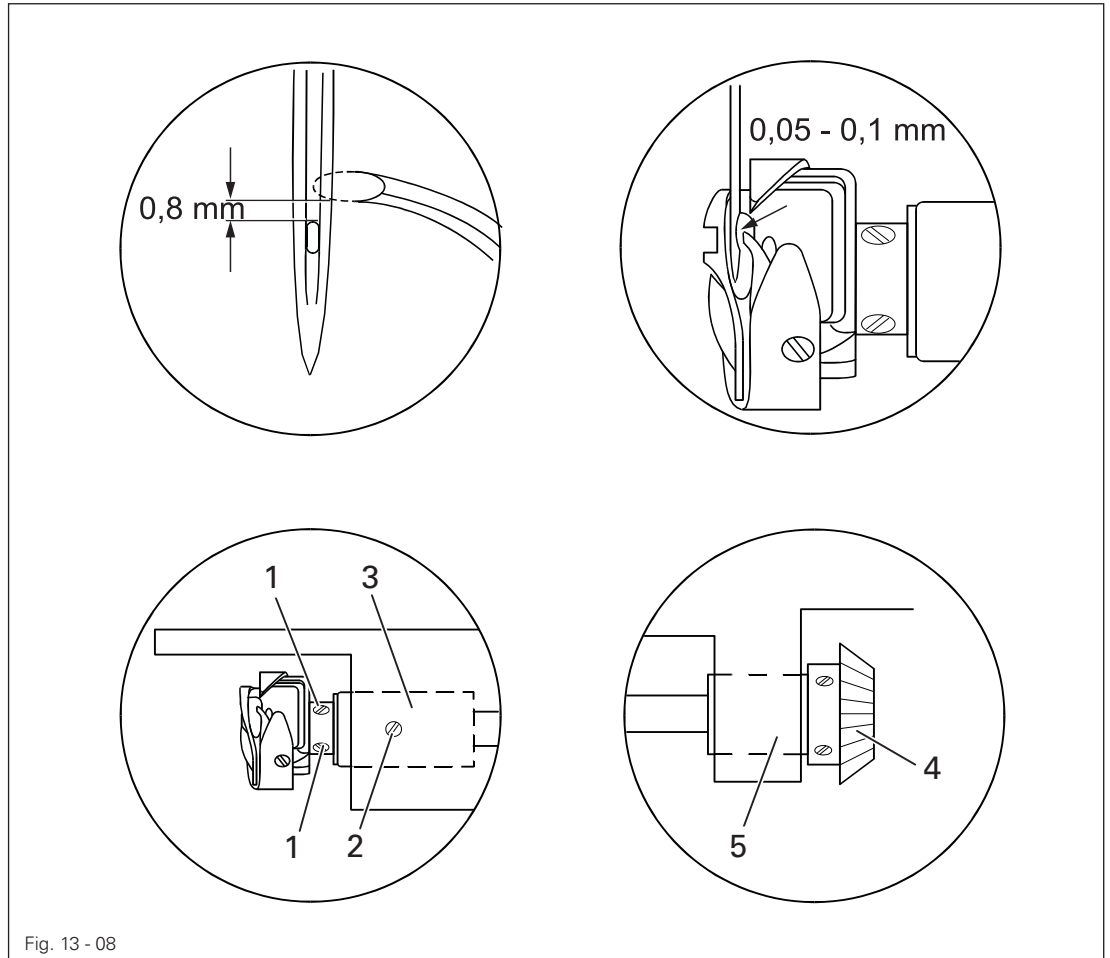
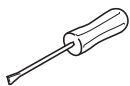

Fig. 13 - 08



- Set the stitch length at "3" and loosen screws 1 and 2 (screw 2 is on the back of the machine).
- Set the needle bar at b.d.c. and place the 1.8 mm thick feeler gauge with its cutout close under the lower needle bar bearing.
- Remove the measuring plate and turn the handwheel in its direction of rotation until the screw clamp is touching the needle bar bearing.
- Move the hook on the hook shaft in accordance with **requirement 1**.
- Rotate the hook in accordance with **requirement 2** (adjust needle height if necessary).
- Bring the hook shaft bearing 3 to rest on the hook and tighten screw 2.
- Taking care to ensure that the bevel gear 4 is resting on the bearing 5, tighten screws 1.

13.04.09 Vibrating presser lift

Requirement

With the vibrating presser lift at maximum and the stitch length set at "0", presser foot 1 and vibrating presser foot 2 must lift 7.0 mm from the needle plate when the handwheel is rotated.

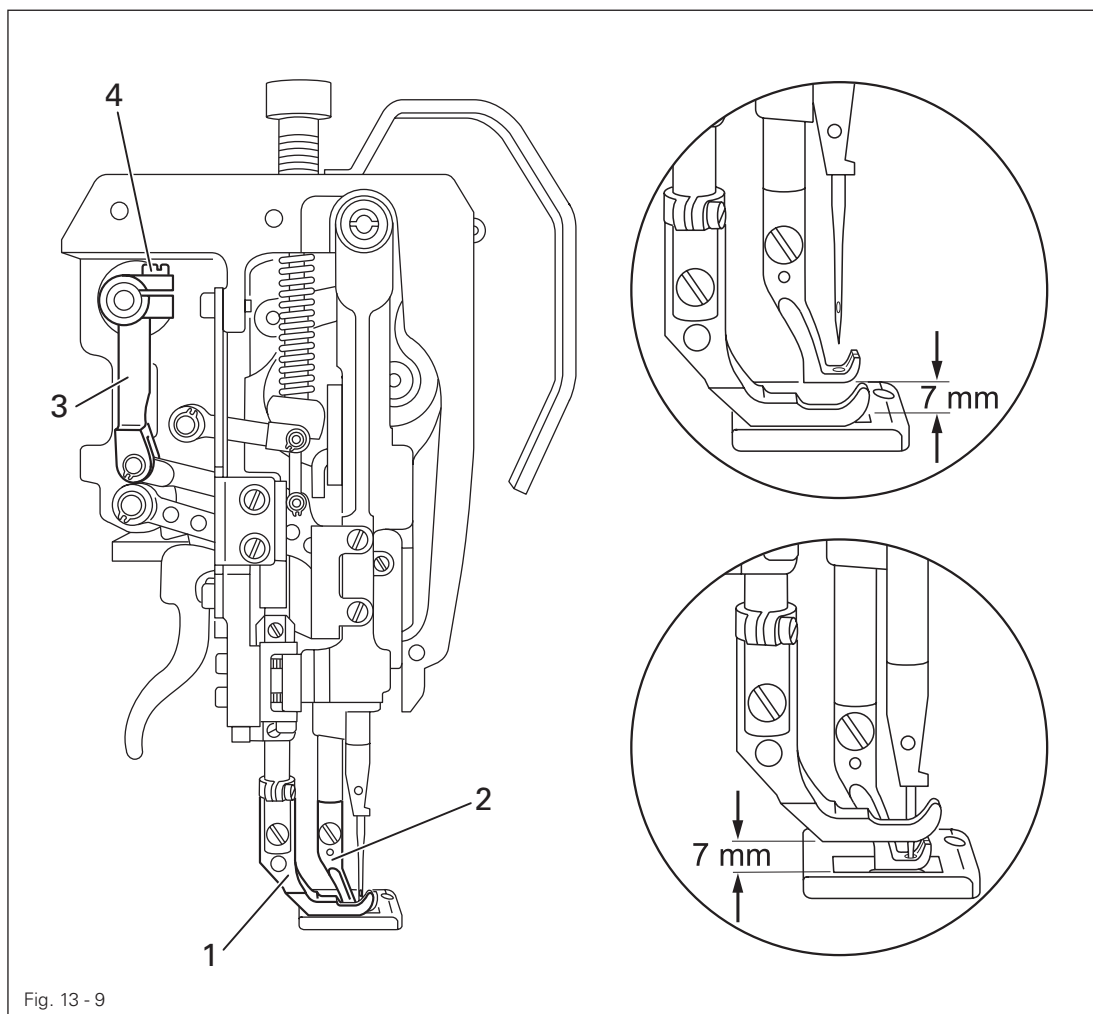
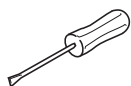

Fig. 13 - 9



- Set the vibrating presser lift at maximum and the stitch length at "0".
- Allow the presser foot 1 to rest on the needle plate.
- Turn the handwheel in its direction of rotation until the vibrating presser foot 2 has reached its highest point.
- Turn crank 3 (screws 4) in accordance with the requirement.
- Carry out a check.

13.04.10 Vibrating presser feeding motion

Requirement

With the presser foot **3** resting on the needle plate the vibrating presser **6** and the needle point must both reach the needle plate at the same time with the vibrating presser stroke at maximum.

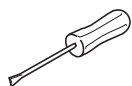
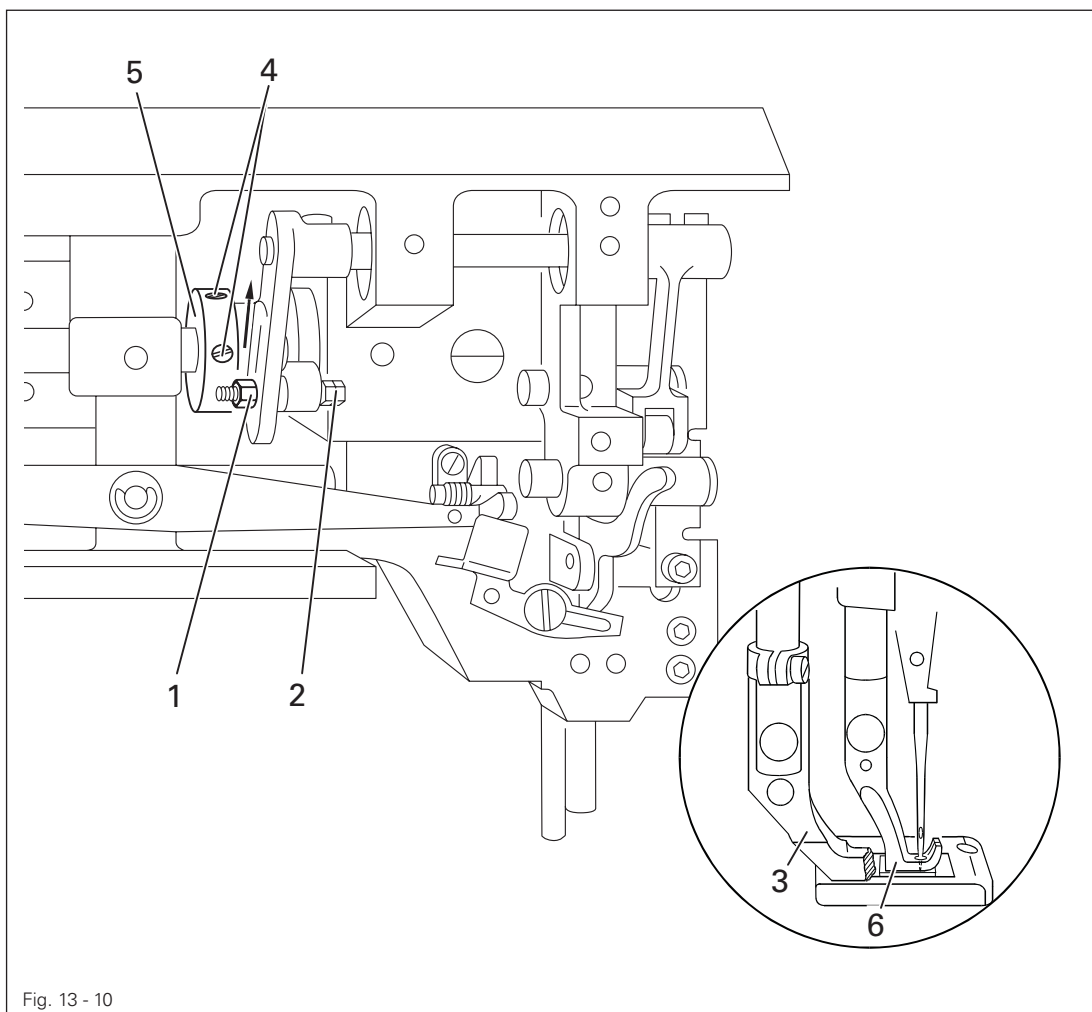

- Loosen nut **1**.
- Slide bolt **2** upwards in the elongated hole and tighten nut **1**.
- Allow the presser foot **3** to rest on the needle plate.
- Loosen screws **4** enough so that the feed lifting eccentric **5** can be rotated with difficulty.
- Rotate the lifting eccentric **5** in accordance with the **requirement**.
- Tighten screws **4**.
- Carry out a check.

Adjustment

13.04.11 Needle thread tension release

Requirement

With the presser foot lifted, the two tension disks must be at least **0.5 mm** apart.



The distance of **0.5 mm** is the minimum clearance. The clearance can range up to more than **1 mm** with thick threads.

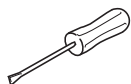
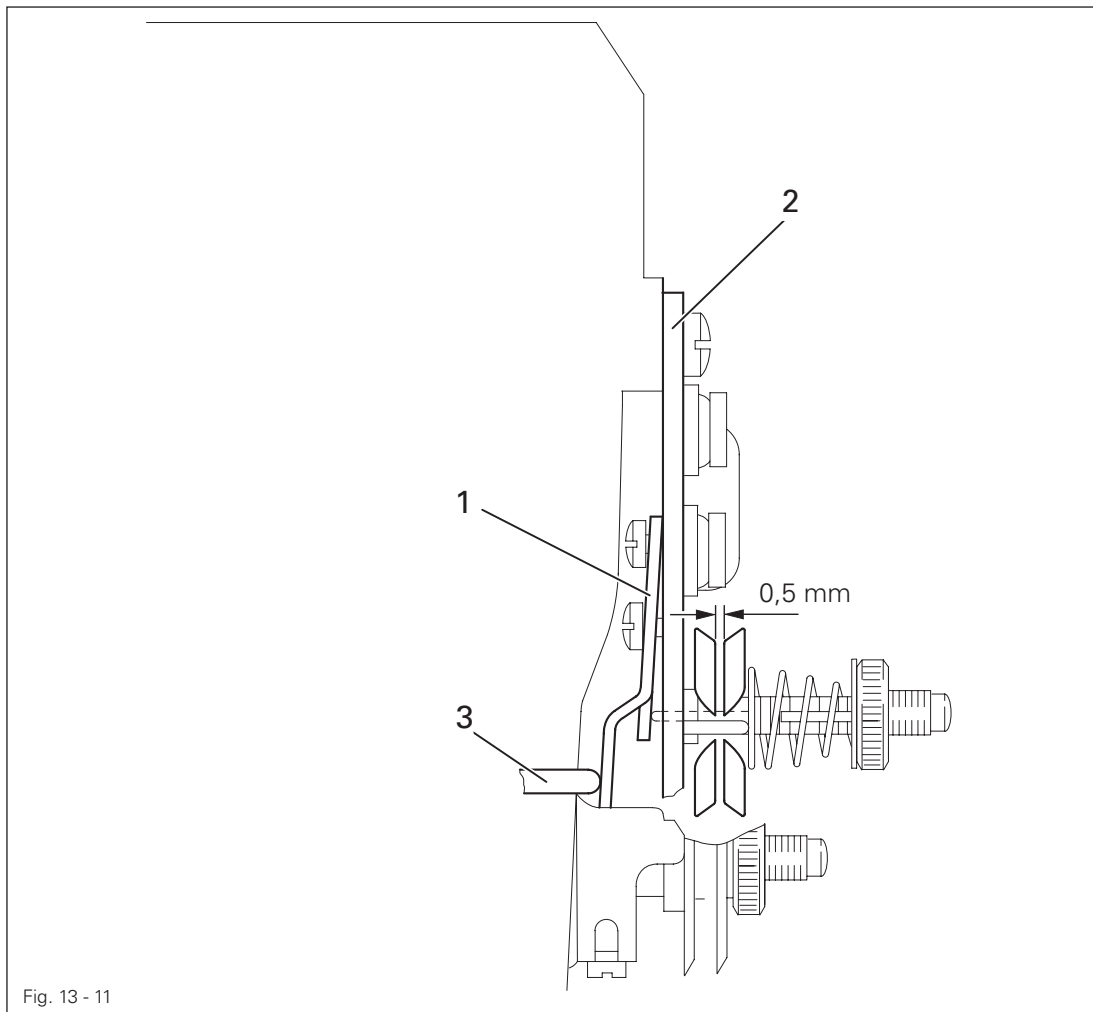

- Raise the presser foot using the hand lever.
- Align the compression plate **1** behind the tension bearing board **2** in accordance with the requirement.



When the tension is correct the release pin must not be under pressure.

13.04.12 Thread check spring

Requirement

The movement of the thread check spring must be finished when the needle point enters the material (= approx. **7 mm** spring movement).



The length of the spring movement can vary a little upwards or downwards due to changes in the sewing parameters.

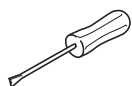
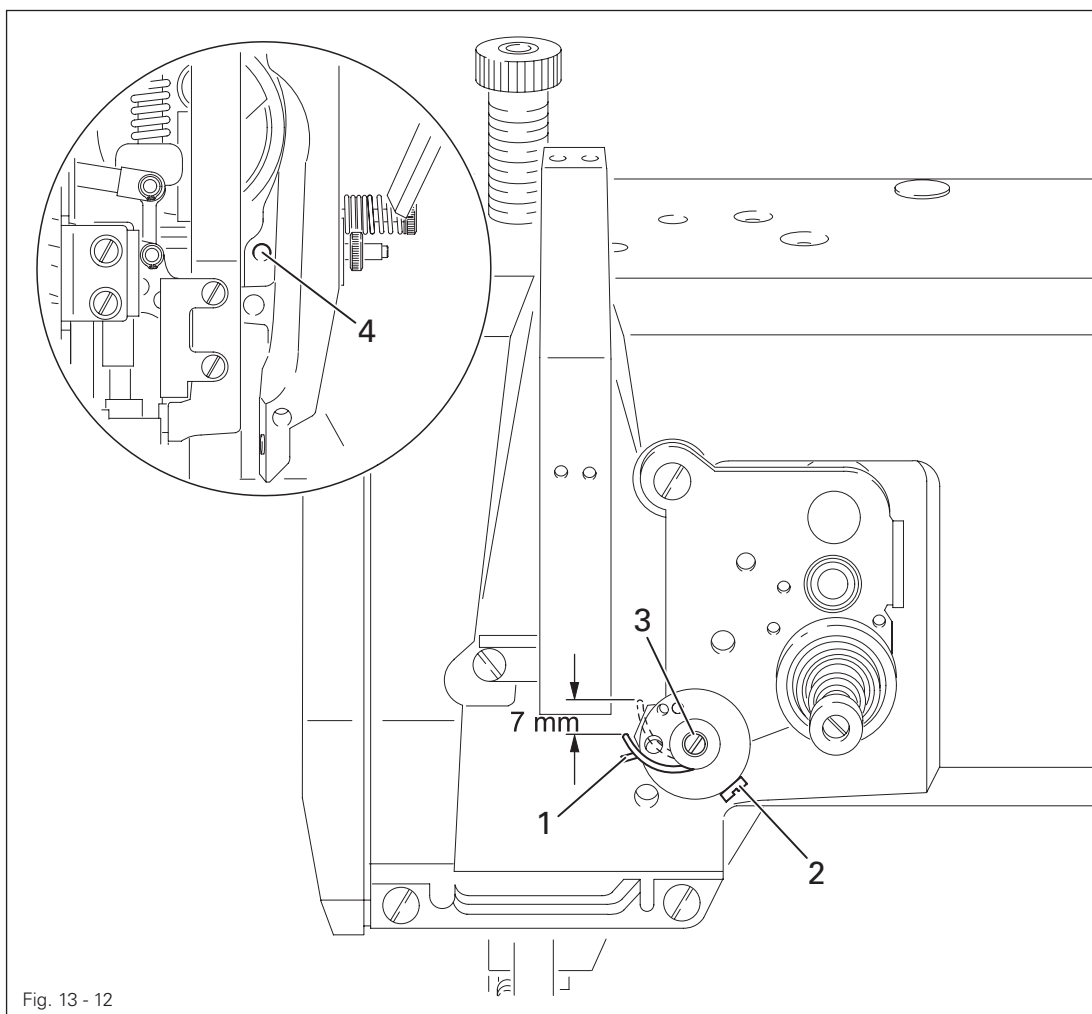

- Adjust stop 1 (screw 2) according to **Requirement**.
- To adjust the pressure of the spring, turn screw 3 (screw 4).

13.04.14 Regulating the pressure on the presser foot

Requirement

The material must be fed perfectly even at top sewing speed. There must not be any pressure marks on the material.

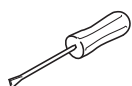
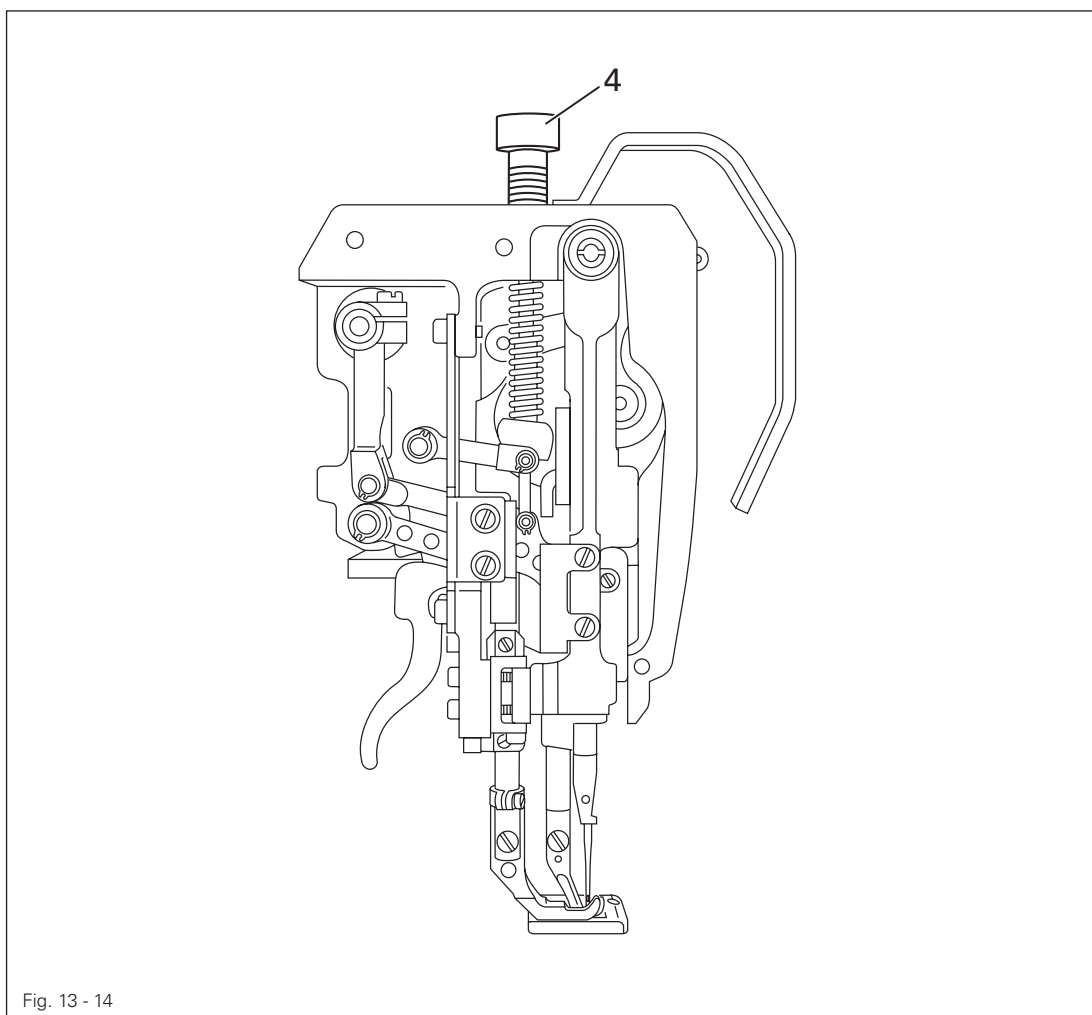

- Turn screw 1 in accordance with the **requirement**.

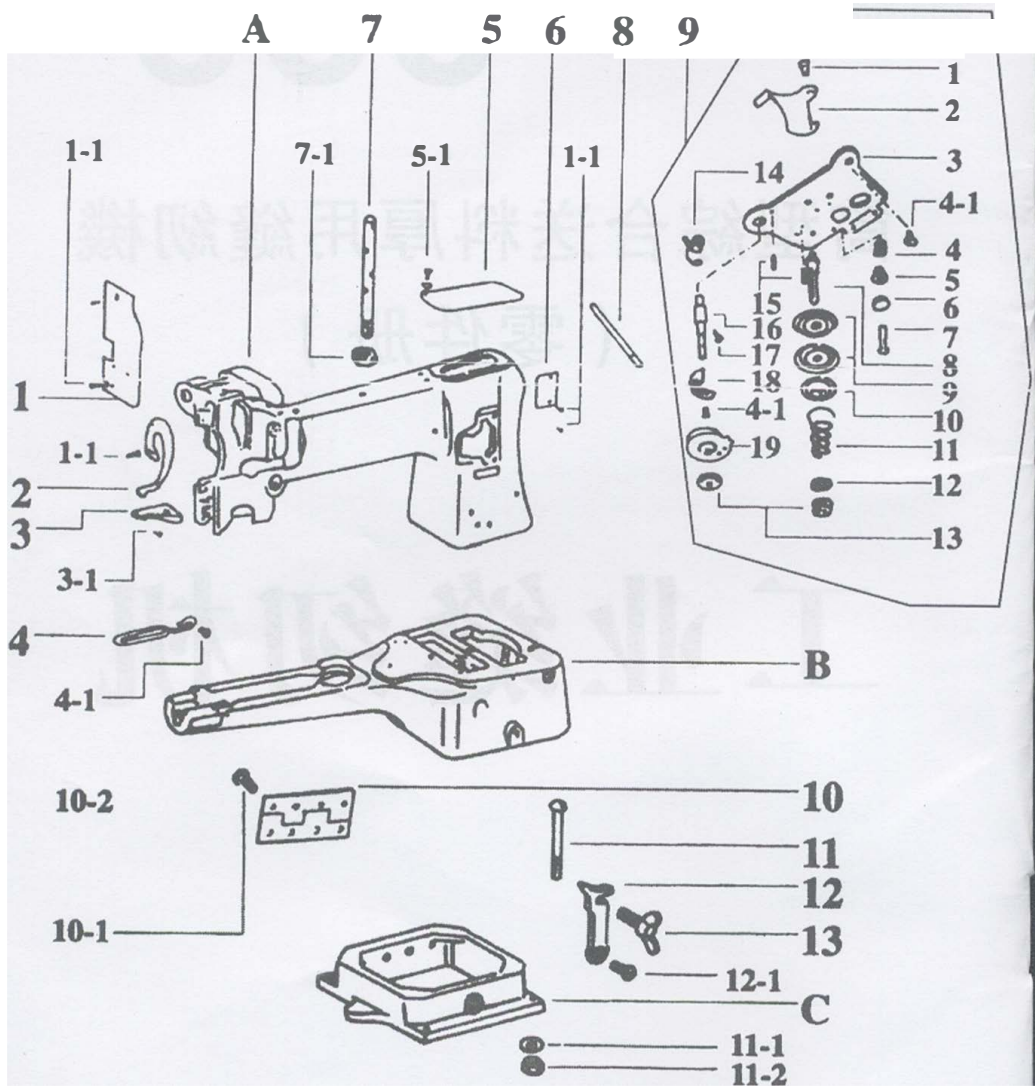

1	FACE PLATE
1-1	FASTENING SCREW
2	LIBRA COVER
3	THREAD GUIDE UPPER
3-1	FASTENING SCREW
4	THREAD GUIDE
4-1	FASTENING SCREW
5	ARM COVER UPPER
5-1	FASTENING SCREW
6	ARM COVER FRONT
7	TENSION COMPLETE SET
7-1	NUT
8	TENSION RELEASE PIN
9	TENSION COMPLETE
9-14	SUSPENSION WIRE SPRING
9-18	ADJUSTMENT BOARD
10	HINGE
10-1	FASTENING SCREW
10-2	SPRING
11	FASTENING SCREW
11-1	CUSHION
11-2	NUT
12	LINK
12-1	FASTENING SCREW
13	FASTENING SCREW
A	GEAR END
B	DOWN BASE
C	FOUR MAO BASE
D	TANK
E	BLOCKING BOARD
E-1	BOLT
102-2	NUT

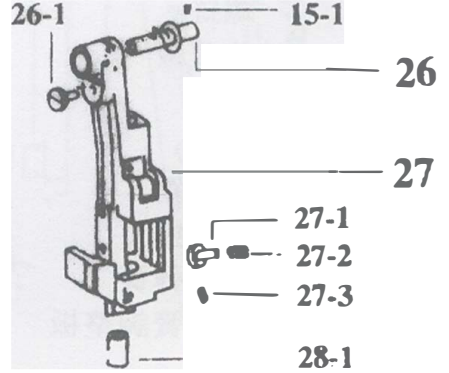
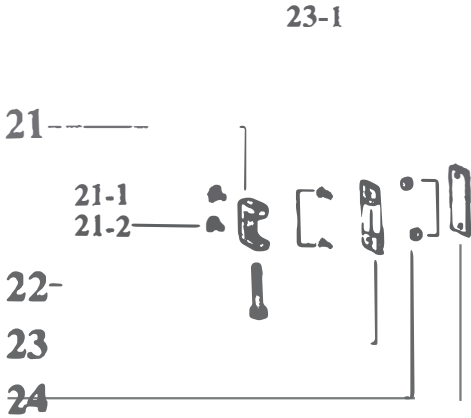
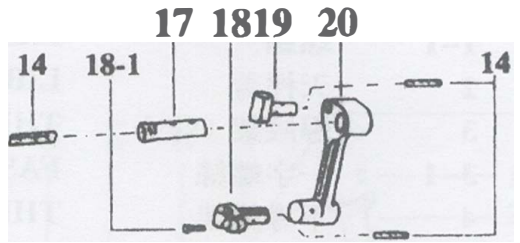
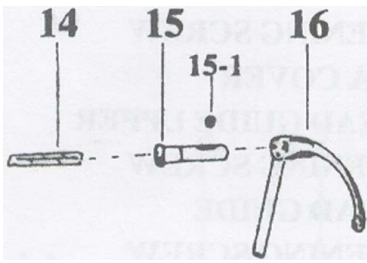

901

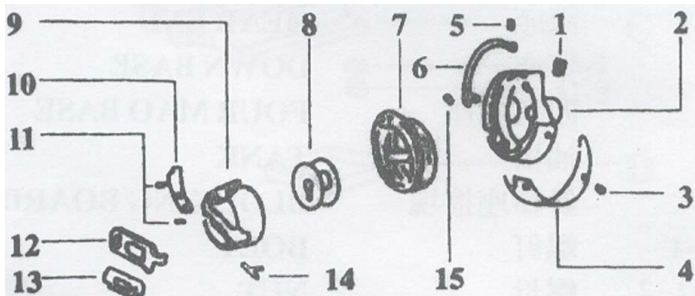
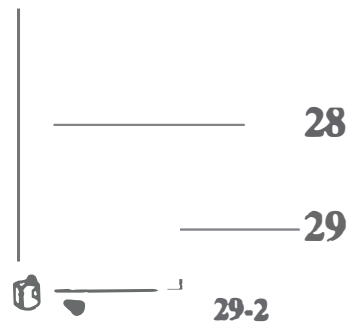

14	WICK
15	LIBRA TIP
15-1	SCREW
16	THREAD TAKE-UP LIBRA
17	NEEDLE BAR LINK HINGE STUD
18	NEEDLE BAR STUD
18-1	FASTENING SCREW
19	TAKE-UP SLEEVE FULCRUM STUD
20	FLEX HANDLE
21	SLIDE BLOCK
21-1	FASTENING SCREW
21-2	FASTENING SCREW
22	FASTENING SCREW
23	LEAD SEAT
23-1	FASTENING SCREW
24	COLLAR
25	NEEDLE BAR GUIDE PLATE
26	NEEDLE BAR FRAME
26-1	FASTENING SCREW
27	NEEDLE BAR FRAME
27-1	NEEDLE BAR FRAME STOR
27-2	CENTER SCREW
27-3	CENTER SCREW
28	NEEDLE BAR
28-1	NEEDLE COLUMN BASE SLEEVE PIPE
29	SPRING
29-2	FASTENING SCREW
901	HOOK

15-1 31-1 15-1 31-1 44-1 31-2

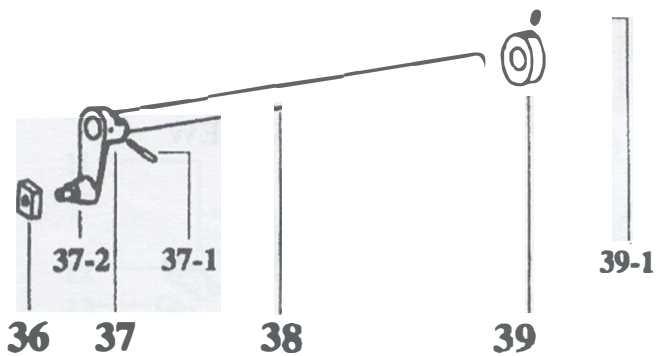
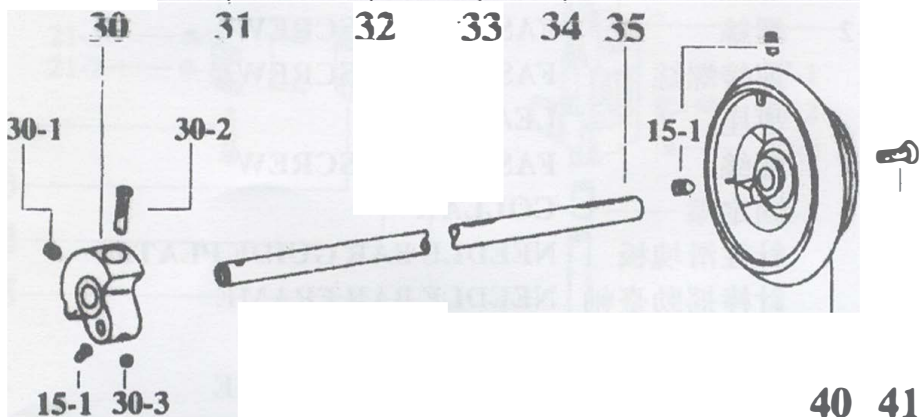
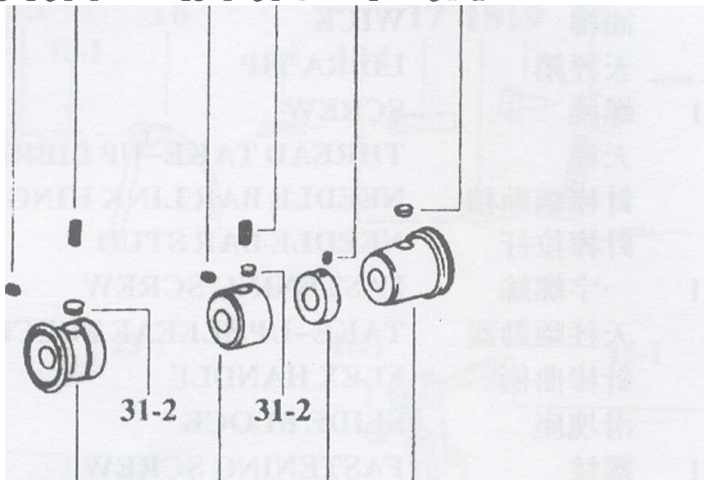

30	FLEX HANDLE
30-1	FASTENING SCREW
30-2	FASTENING SCREW
30-3	FASTENING SCREW
30-4	SCREW
31	UP SHAFT FRONT BUSHING
31-1	FELT
31-2	WICK
32	FELT
33	BEVEL GEAR CASING CAP COLLAR
33-1	FASTENING SCREW
34	ARM SHAFT BUSHING BACK COVER
35	ARM SHAFT
36	SLIDE BLOCK
37	BENDED PIN IN FRONT OF WAVING THE AXLE
37-1	OBLIQUE TIP
37-2	WAVE AND SLIP ONE PIN
38	THE NEEDLE WAVES THE AXLE EXCELLENTLY
39	SET COLLAR
39-1	FASTENING SCREW
40	BALANCE WHEEL
40-1	FASTENING SCREW
41	FASTENING SCREW

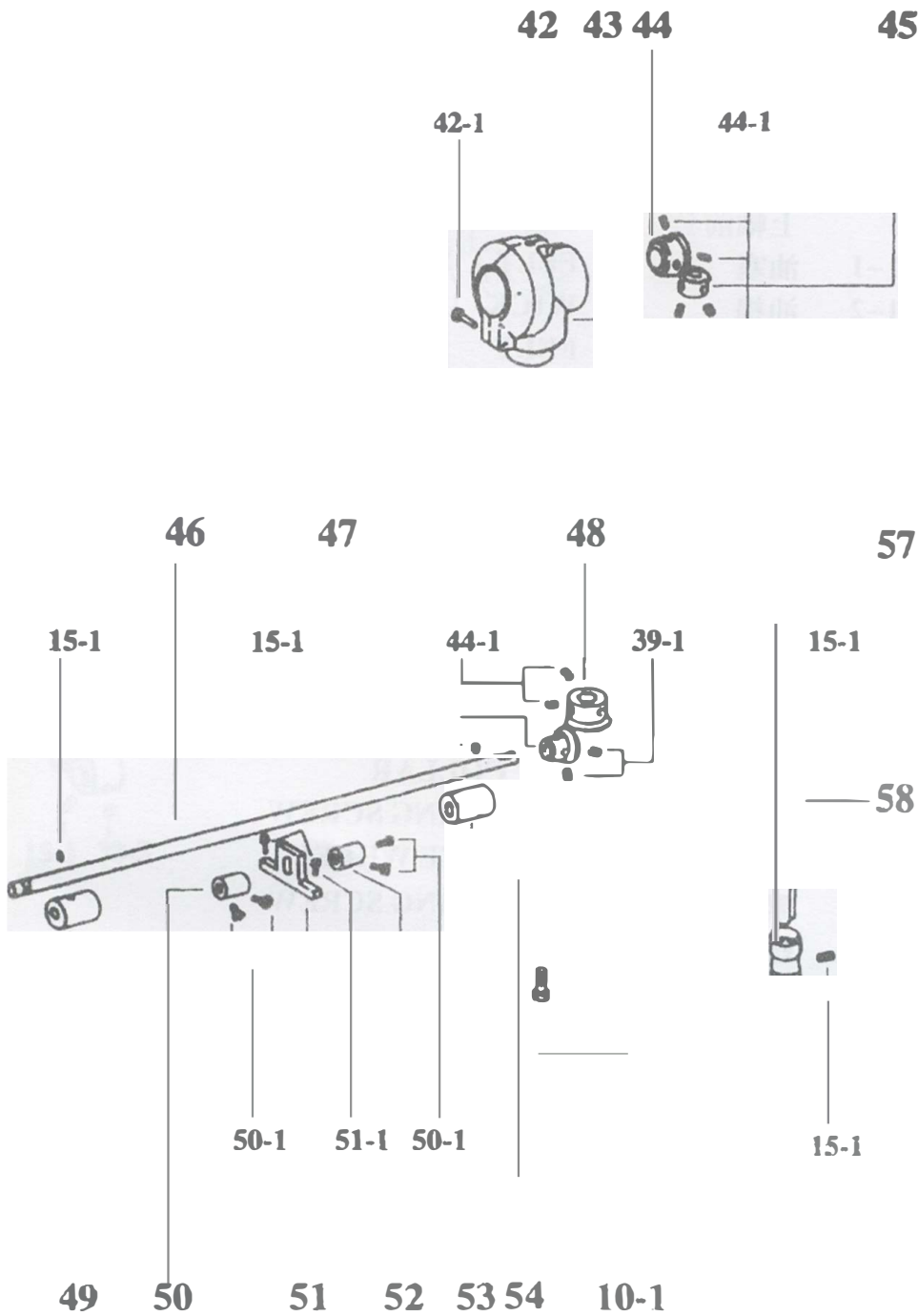

42	BEVEL GEAR CASING COMPLETE
42-1	SCREW
43	BEVEL GEAR CASING COMPLETE
44	GEAR SET
44-1	FASTENING SCREW
45	GEAR SET
46	HOOK DRIVING SHAFT
47	GEAR SET
47-1	SCREW
48	GEAR SET
49	FRONT SLEEVE FOR HOOK SHAFT
50	DOWN SHAFT COLLAR
50-1	FASTENING SCREW
51	HOOK SHAFT BASE
51-1	FASTENING SCREW
52	DOWN SHAFT COLLAR
53	KISS COVER AFTER PUTTING THE AXLE
54	BEVEL GEAR CASING UNDER
54-1	SCREW
57	BEVEL GEAR SHAFT BUSHING VERTICAL UPPER
58	BEVEL GEAR SHAFT VERTICAL.
60	BEVEL GEAR SHAFT BUSHING VERTICAL. UPPER

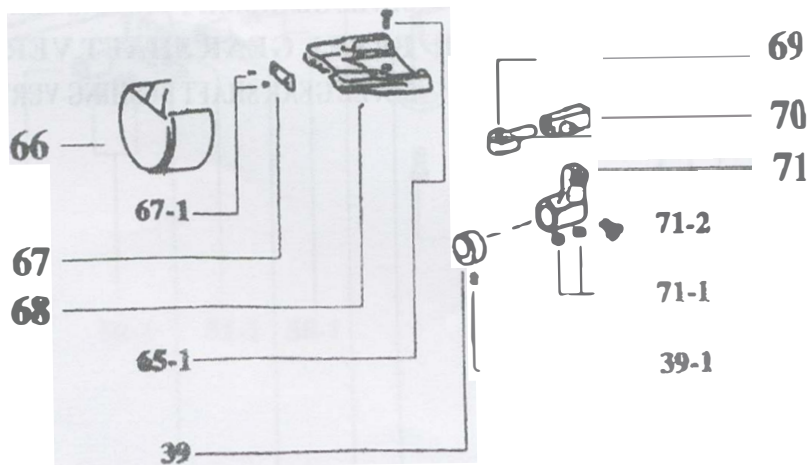
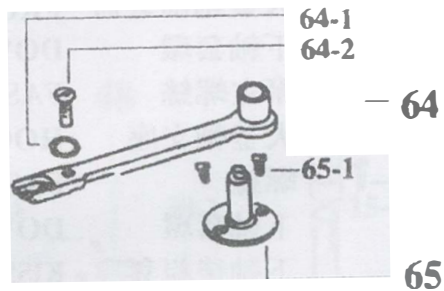
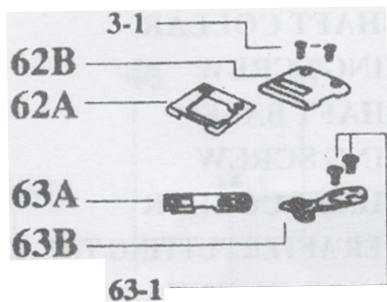
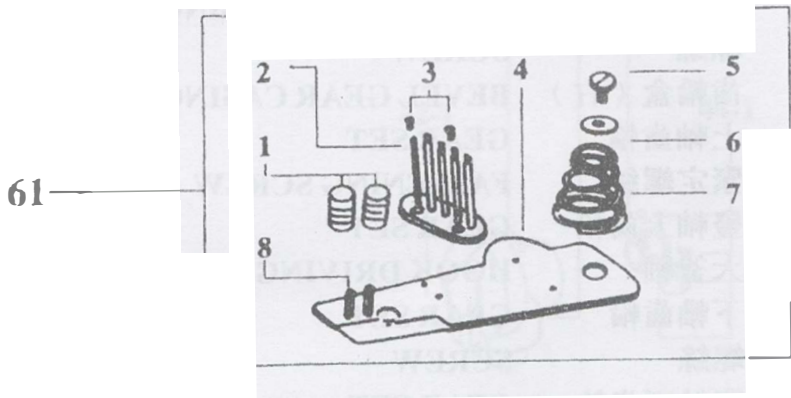

61	GAUGE PLATE SET
61-1	NUT
61 2	FABRIC SUPPORT POLE
61-3	SCREW
61-4	FIXTURE BOARD
61-5	SCREW
61 6	CUSHION
61 7	SPRING
61-8	SCREW
61-9	FABRIC SUPPORT PLATE
62-1	FASTENING SCREW
62A	NEEDLE PLATE
62B	NEEDLE PLATE
63-1	FASTENING SCREW
63A	TUBAEFORM TOOTH
63B	PLANEFORM TOOTH
64	FEEDING ROCKER
64-1	CUSHION
64-2	BOLT
65	FEEDING PLATE SHAFT
65-1	FASTENING SCREW
66	HOOK COVER
67	NEEDLE EGIS SUPPORT
67- 1	SCREW
68	NEEDLE BORAD BASE
68 -1	SCREW
69	FEEDING SLIDE VALVE
70	SLINE VALVE BASE
71	FEEDING DRIVER
71-1	FASTENING SCREW
71-2	FASTENING SCREW

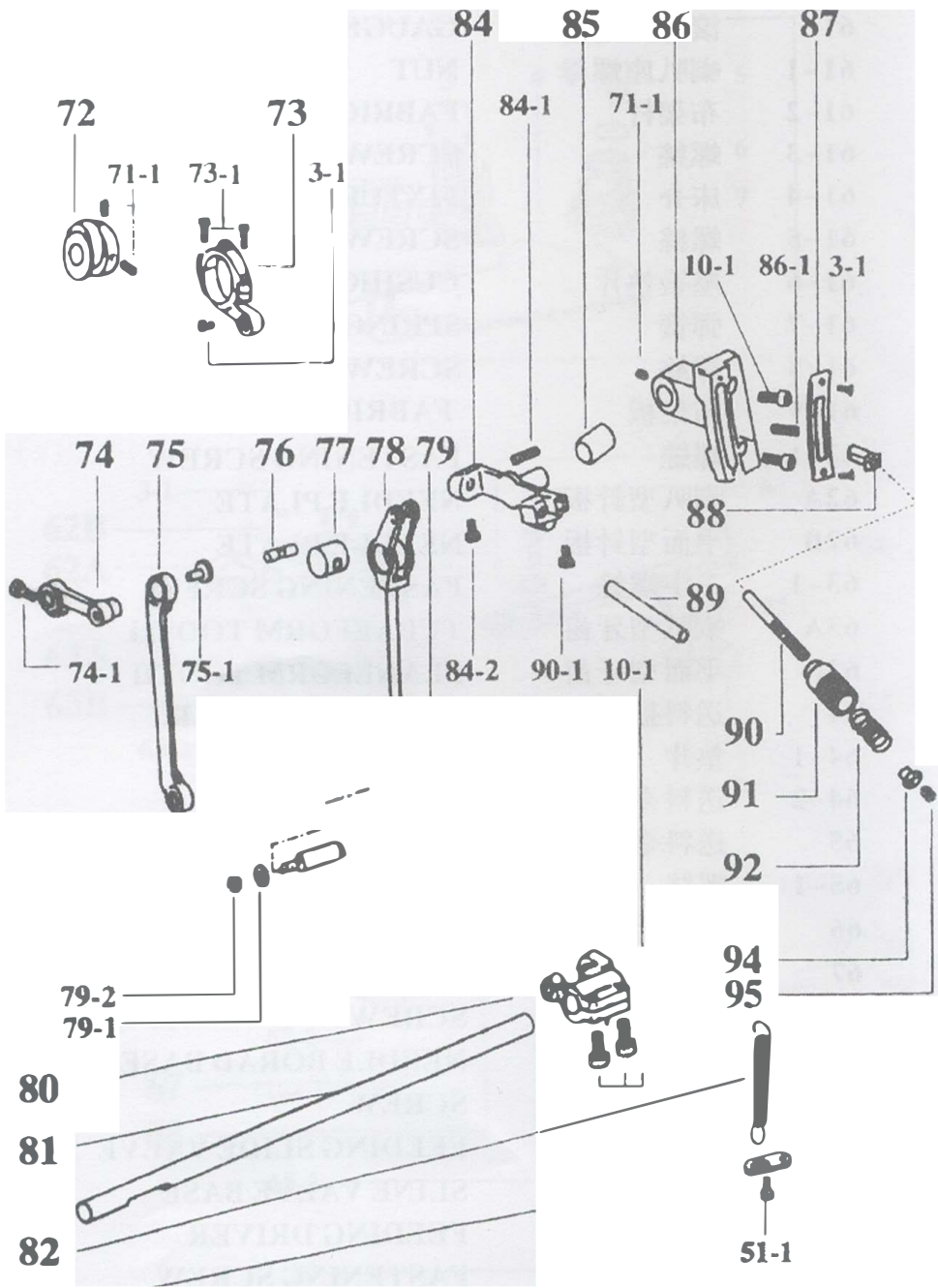

72	PARTIAL FEEDING CAM
73	DRIVER ROD
73 1	SCREW FOR DRIVER ROD
74	BACK FLEX HANDLE
74-1	FASTENING SCREW
75	CONNECTION POLE
75-1	FASTENING SCREW
76	FLEX SHAFT END
77	SLIPPERY SET
78	FORK CONNECTION POLE
79	FEEDING CONNECTION END
79-1	CUSHION
79-2	FASTENING SCREW
80	FLEX POLE
81	FEEDING SHAFT
82	SPRING FOR FEEDING CONTROL.
83	SPRING BASE
84	SLIPPERY SET BASE
84-1	EXTENSION SPRING SCREW
84-2	FASTENING SCREW
85	COVER
86	CONTROL BASE FOR NEEDLE DISTANCE
86-1	SPRING FOR FEEDING CONTROL.
86-2	FASTENING SCREW
87	SCALE PLATE
88	LEAD SET FOR FEEDING CONTROL
89	SLIPPERY SHAFT
90	CONTROL SHAFT
91	HANDLE CONTROL FOR NEEDLE DISTANCE
92	SPRING
94	NUT
95	SCREW

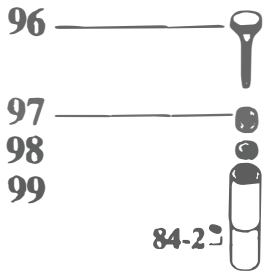

100

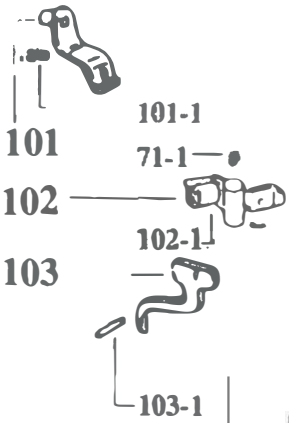

104



106

107A

107B

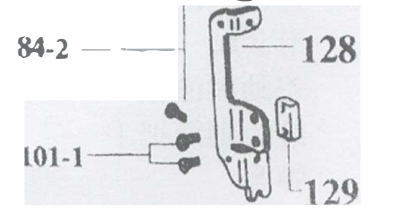
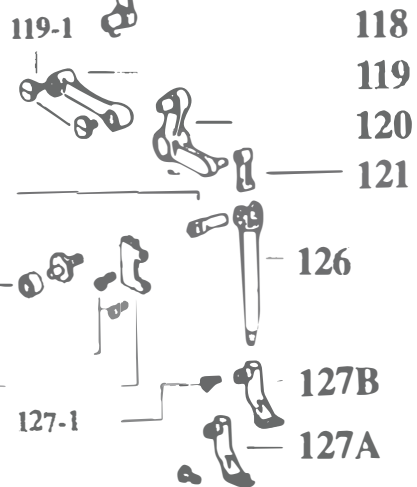
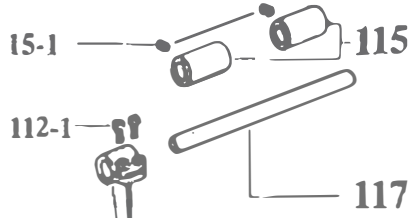
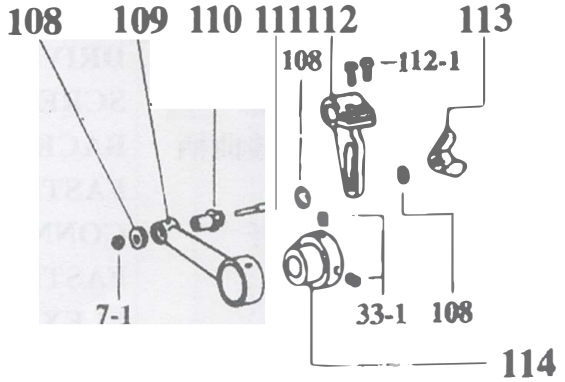

96	BOLT FOR TENSION CONTROL
97	SCREW CAP
98	SPRING TRAY
99	PRESS ROD SLEEVE PIPE
99-1	BOLT
100	PRESS ROD SPRING (FLAT)
101	SHOULDER POLE STAND(PACKAGE)
101-1	FASTENING SCREW FOR
102	PRESSER BAR GUIDE COLLAR
102-1	CONNECTION BOLT
102-2	NUT
103	LIFTING HANDLE
103-1	LIFTING HANDLE END
104	PRESSER BAR
104-1	SCREW
105	SPRING PRESSER POLE
106	SPRING
107A	OUTER PRESSER FOOT
107B	FLAT PRESSER FOOT
108	WASHER
109	UP FEEDING POLE DRIVER
110	CONNECTION BOLT FOR UP FEEDING
111	ROCKER ARM
112	UP FEEDING ROCKER ARM
112-1	FASTENING SCREW
113	FASTENING SCREW
114	PARTIAL WHEEL
114-1	SCREW
115	BUSHING
117	UP FEEDING SHAFT
118	UP FEEDING ROCKER
119	UP FEEDING CONNECTING ROD
119-1	FASTENING SCREW
120	TRIANGULAR ROCKER ARM
121	SHAKING CONNECTION ROD
122	PRESS POLE TIP
123	CONNECTION GUIDE POST
124	ROLLER
125	PRESS POLE LEADING BASE
126	PRESS SHAFT
127 1	SCREW
127A	ESCORT THE FOOT IN THE SHAPE OF THE LOU DSPEAKER
127B	PRESS THE FOOT INSIDE
128	FIXTURE BOARD
128 1	SCREW
129	FIXTURE SLIP
129 1	FASTENING SCREW

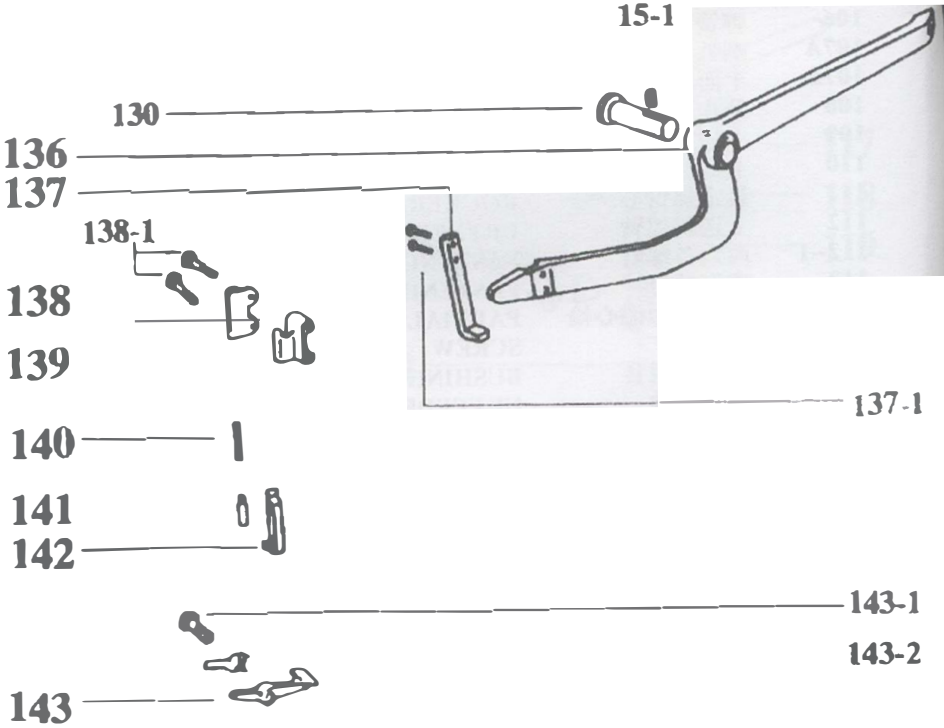
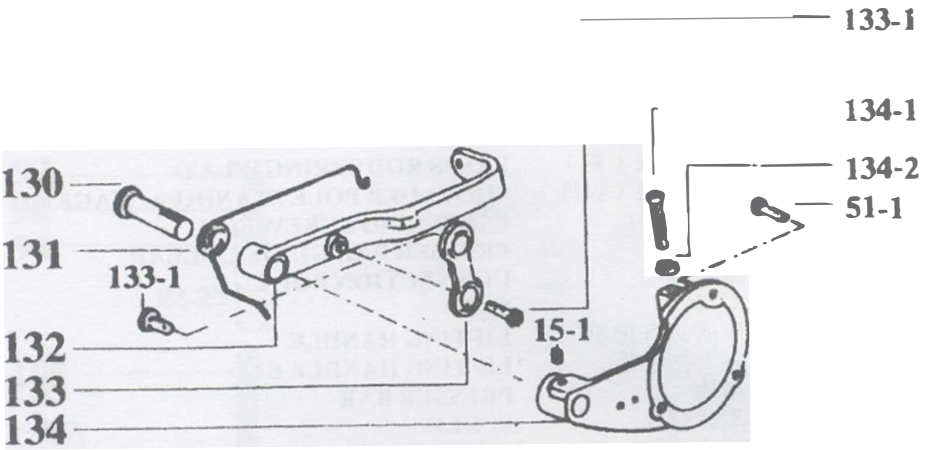

130	LEVER PIVOT
131	SPRING
132	SHORT LEVER
133	CONNECTING ROD OF THE LEVER
133-1	LEVER SCREW
134	BACK CASE LID
134-1	SCREW
134-2	NUT
134-3	SCREW
136	LONG LEVER
137	CLIVER
137-1	FASTENING SCREW
138	GUIDE SEAT
138-1	SCREW
139	BOLT PIN SEAT
140	BOLT PIN SPRING
141	BOLT PIN
142	SLIPPY BOARD
143	SHAKING BOARD
143-1	SCREW
143-2	SHRAPNEL

144



150



145



151

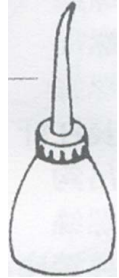

146



147



152

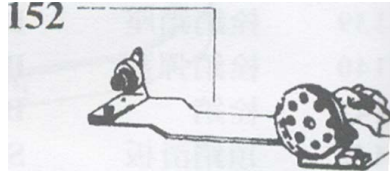

148



153



149



144	BIG OPENER
145	MIDDLE OPENER
146	SMALL OPENER
147	SHUTTLE
148	NEEDLE
149	DUSTPROOF COVER
150	ACCESSORY BOX
151	DIL BOAT
152	FEEDING LINE IMPL EMENT
153	IRON SHOE

154 —

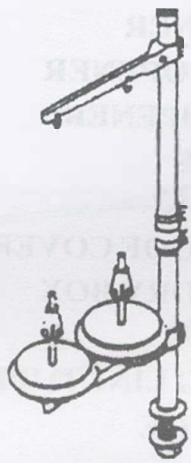

155 —

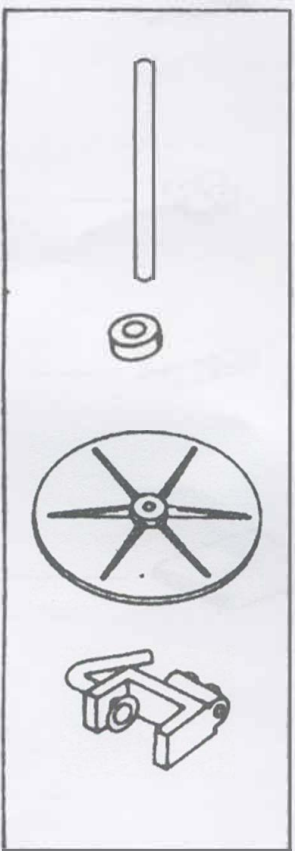

— 156

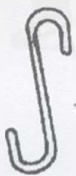

157 —

154

LINE TWO SHELF OF THE MODEL L

155

THREAD TRAY

156

RUBBER CUSHION

157

CHAIN & CHAIN HOOK

335-8B

1 2



3 4-A

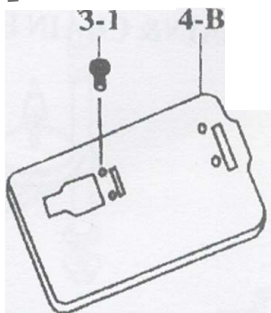

5

6 7 8

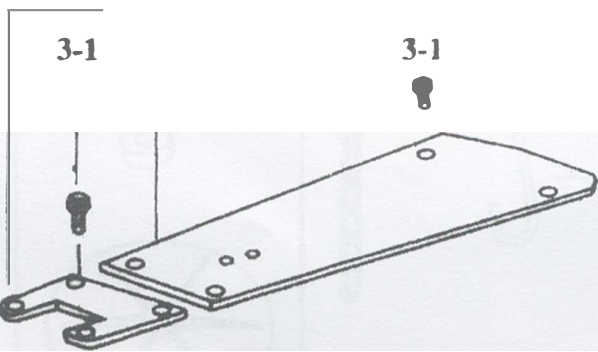
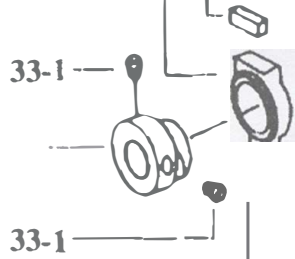

9

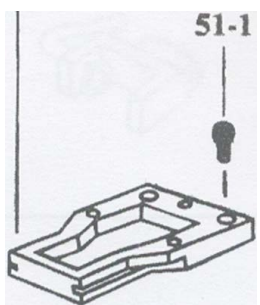

10 11

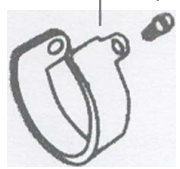

28E

- 1 NEEDLE PLATE
- 2 SCREW
- 3 FIXTURE PIECE FOR NEEDLE PLATE BASE
- 3-1 SCREW
- 4-A SMALL EGIS COVER
- 4-B BIG EGIS COVER
- 5 CONVEXITY WHEEL
- 6 CONNECTION POLE
- 7 WICK
- 8 SPRING
- 9 NEEDLE PLATE BASE
- 10 COVER RING
- 11 SCREW
- 33-1 SCREW
- 51-1 SCREW

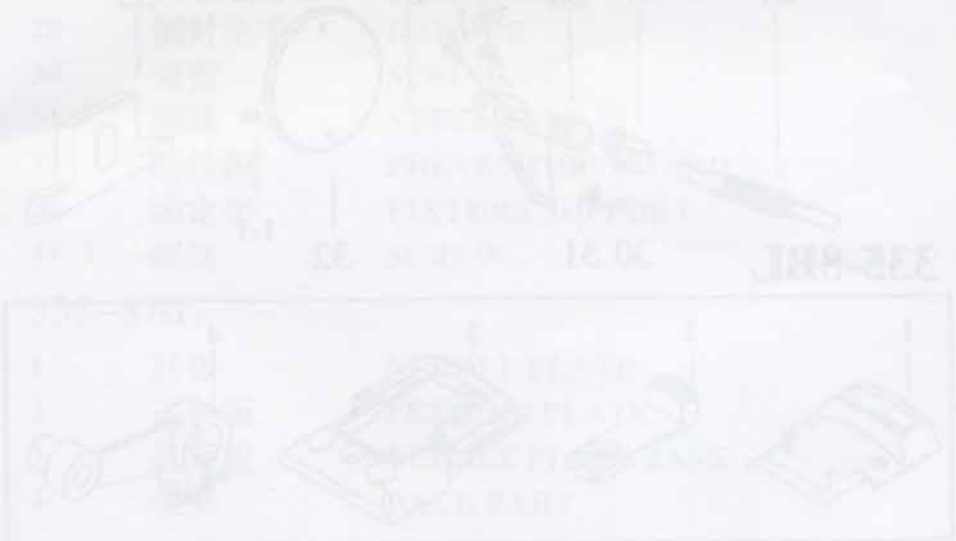

335

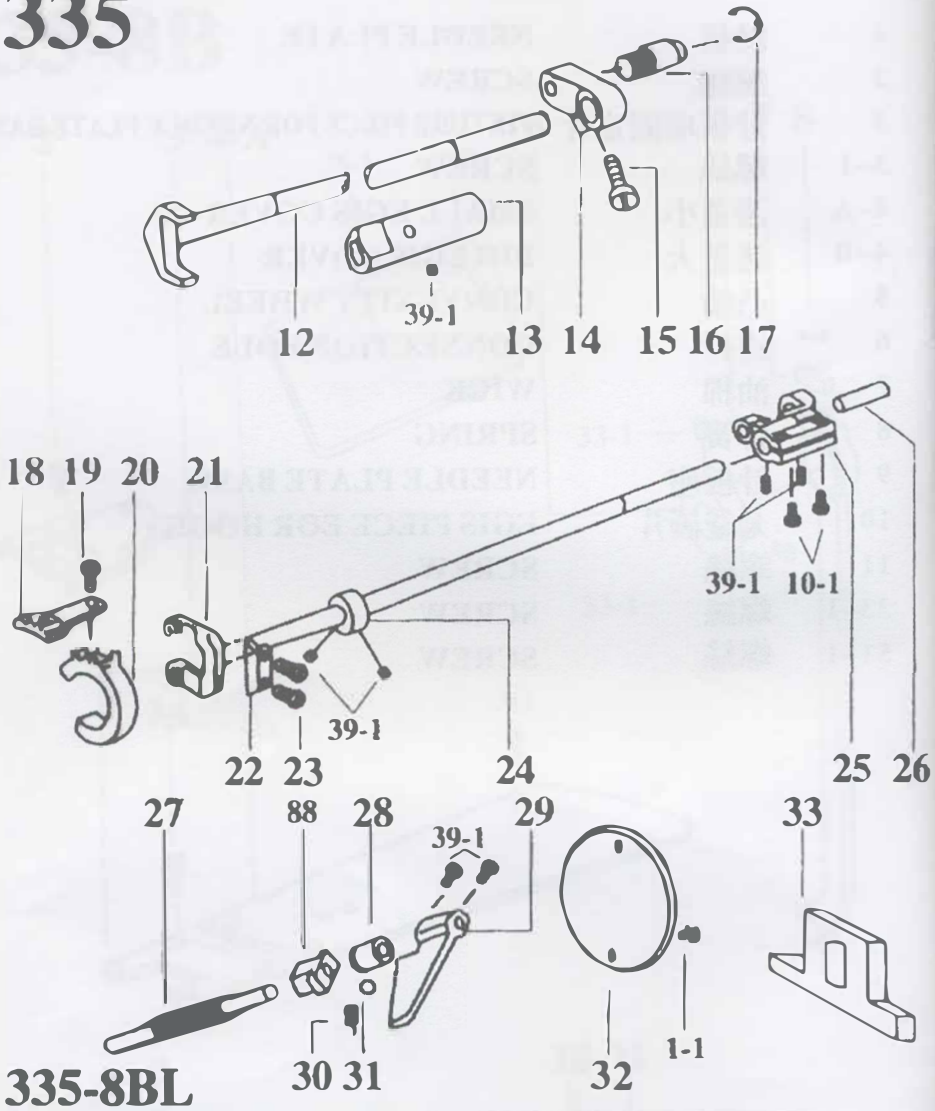

335-8BL

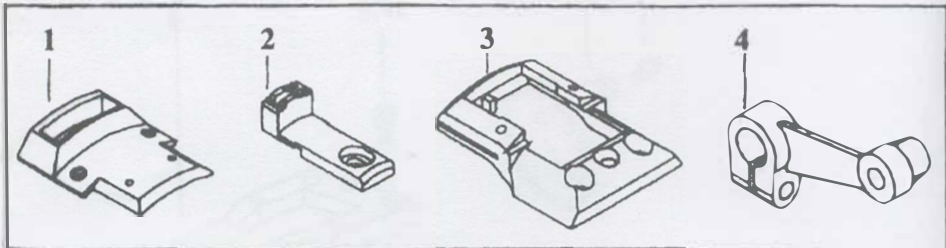

1-1	SCREW
10-1	SCREW
12	SHORT FEEDING SHAFT
13	DOWN SHAFT BUSHING
14	FEEDING DRAWING POLE
15	SCREW
16	CONNECTION POLE TIP
17	BUCKLE RING
18	FEEDING TOOTH
19	SCREW
20	FEEDING TOOTH BASE
21	FEEDING SUPPORT
22	FIXTURE PIECE FOR FEEDING SUPPORT
23	SCREW
24	COLLAR
25	FLEX HANDLE
26	FLEX TIP
27	SCREW
28	NUT
29	HANDLE
30	SPRING
31	STEEL BALL
32	PREVENTION BOARD
33	FIXTURE SUPPORT
39-1	SCREW
335-8BL	
	NEEDLE PLATE
2	FEEDING PLATE
3	NEEDLE PLATE BASE
4	BACK PART