

# ARTISAN®

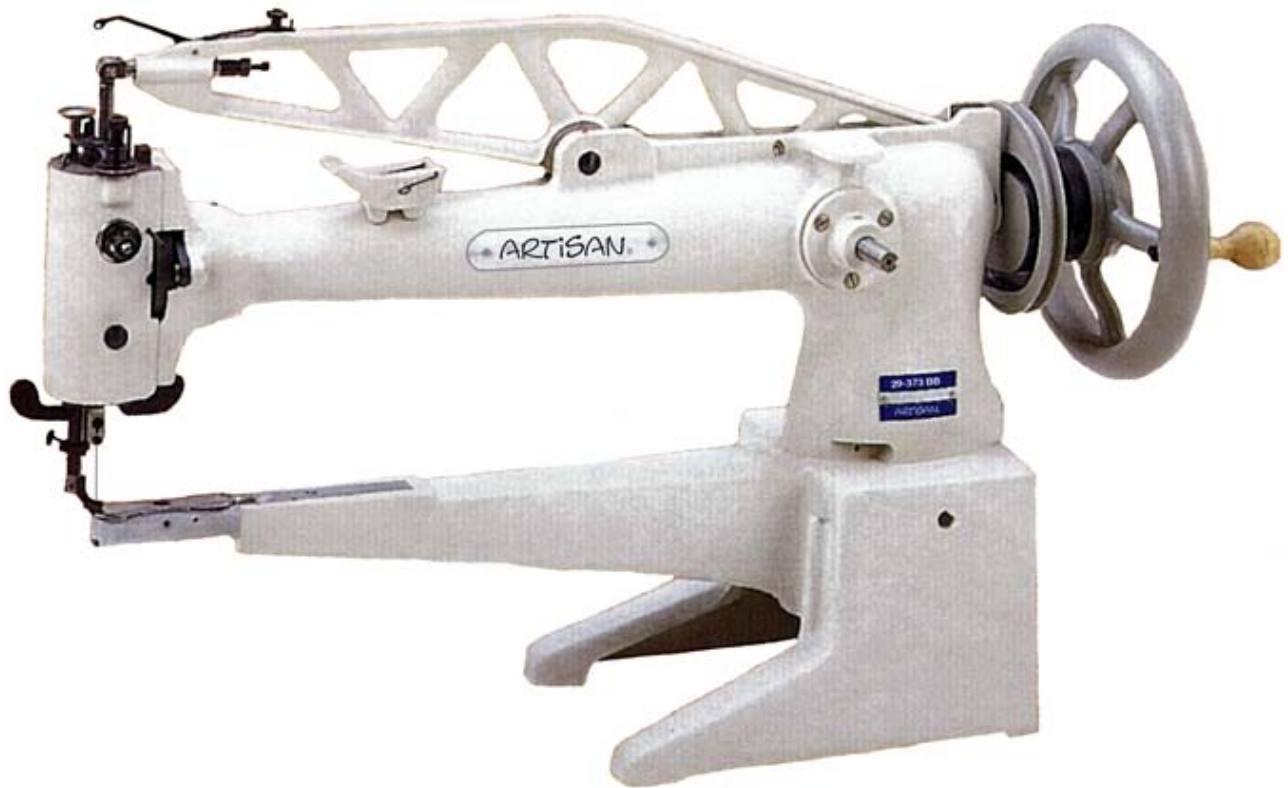

## ARTISAN®

**29-72** Short Arm 12" **29-273** Long Arm 18"  
Universal Feed, "Patching" Machines.

**Operators Manual  
and  
Spare Parts Booklet**

## CONTENTS

DESCRIPTION .....	1	NEEDLE THREAD TENSION .....	10
SPEED .....	3	BOBBIN THREAD TENSION .....	10
LUBRICATION .....	3	REGULATING LENGTH OF STITCH .....	10
OPERATION .....	4	REGULATING TAKE-UP LEVER TENSION .....	11
NEEDLES .....	4	ADJUSTING TRAVEL OF TAKE-UP LEVER .....	11
THREAD .....	4	REGULATING PRESSURE ON THE MATERIAL .....	12
BOBBIN REMOVAL .....	5	TURNING A CORNER .....	12
BOBBIN WINDING .....	5	REGULATING AUTOMATIC LIFT OF FEEDING FOOT .....	12
SHUTTLE THREADING .....	6	CHANGING DIRECTION OF FEED .....	12
(29U171A, 29U173A)		CHANGING NEEDLE PLATE .....	12
SHUTTLE THREADING .....	7	EXAMINATION FOR REMOVAL AND REPLACEMENT OF GEAR BOX .....	13
(29U172A)		INSTRUCTIONS FOR REMOVAL OF GEAR BOX .....	13
SHUTTLE REPLACEMENT .....	8	SHUTTLE TIMING .....	14
THREADING .....	8	HINTS FOR PERFECT OPERATION .....	15
THREADING FOR DARNING .....	9		
PREPARING FOR SEWING .....	9		
SEWING .....	9		

## DESCRIPTION

Machines 29U171A, 29U172A and 29U173A, for stitching boots, shoes, and other tubular work in leather and fabrics, have the following characteristics:

Single Needle, Lock Stitch.

Stop Motion Hand Wheel — releases hand wheel from stitching mechanism for bobbin winding.

Horizontal Oscillating Shuttle.

Eccentric Adjustment for Shuttle Timing.

Cylinder Bed.

Replaceable Steel Horn.

Universal Upper Feed for stitching in any direction without turning the work.

Stitch Length: 5 to 15 per inch (5.1 to 1.7mm), depending on material being stitched and operations performed.

Presser Foot rise during feeding action: 1/4 inch (6.4mm) — Maximum clearance: 3/8 inch (9.5mm)

Double End Needle Plate — (two sizes of needle holes at each end for various sizes of needles).

Adjustable Thread Take-up Lever.

Two Speed Machine Pulley.

## SPECIAL FEATURES

### MACHINE 29U171A

End of cylinder bed 1 inch (25.4mm) wide and 7/8 inch (22mm) thick.

Space at right of needle 12-1/4 inches (311.2mm).

Diameters of belt grooves 2.91 inches (74mm) and 9.46 inches (126mm).

### MACHINE 29U172A

End of cylinder bed 1-5/32 inches (29.4mm) wide and 1-1/16 inches (27mm) thick.

Space at right of needle 17-1/2 inches (444.5mm)

Diameters of belt grooves 3.70 inches (94mm) and 5.55 inches (141mm).

Large Bobbin.

### MACHINE 29U173A

End of cylinder bed 1 inch (25.4mm) wide and 7/8 inch (22mm) thick.

Space at right of needle 17-1/2 inches (444.5mm).

Diameters of belt grooves 3.70 inches (94mm) and 5.55 inches (141mm).

## SPEED

The maximum speed recommended for these machines is 500 stitches per minute, depending on material being stitched and operations performed.

For thick work, patching, mending, and stitching elastics, put the driving belt on the larger pulley of the machine and the smaller pulley of the stand.

For light work, put the belt on the smaller pulley of the machine and the larger pulley of the stand.

When in operation, the hand wheel must always turn over toward the right (clockwise).

NOTE: If fitted at end of machine, hand wheel must always turn over toward the operator (counter-clockwise).

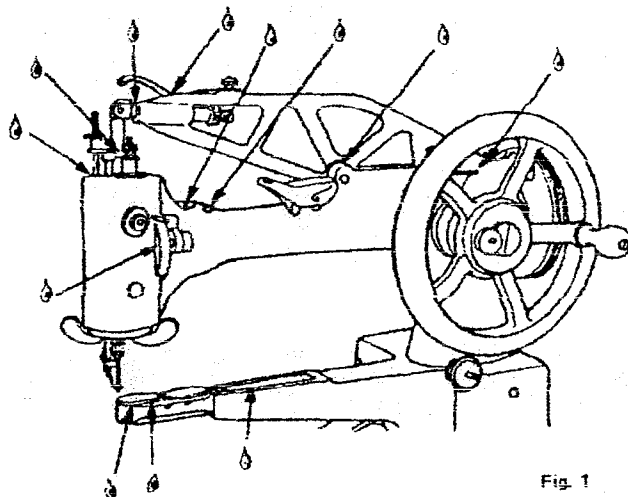

Fig. 1

## LUBRICATION

When machine is received from the factory, it should be thoroughly cleaned and a drop of oil should be applied to all parts indicated in Figs. 1, 2 and 3.

Run machine for a few minutes to work oil into bearings. When the machine is in constant use, it should be oiled daily.

Use SINGER "TYPE B" or "TYPE D" OIL.

To oil shuttle race, raise needle bar to its highest point and lift feeding foot shown in Fig. 4 by moving lifter upward.

Apply a drop of oil to the face of shuttle race and to the holes shown in Fig. 3.

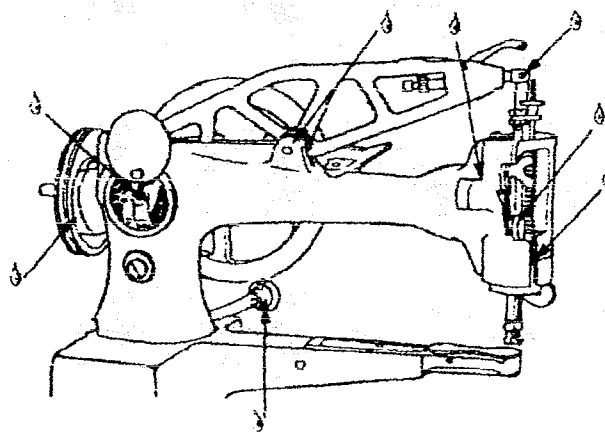

Fig. 2

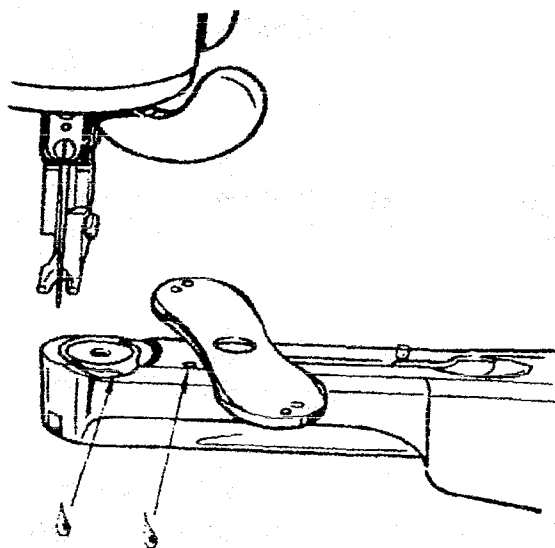

Fig. 3

## OPERATION

1. Raise feeding foot shown in Fig. 4 by moving lifter upward.
2. Place both feet upon the treadle.
3. Turn top of hand wheel from left to right to start machine. (If hand wheel is fitted on side of machine, turn top of hand wheel over toward you to start machine.)
4. Place a piece of material under the feeding foot. Lower feeding foot by lowering lifter and operate machine until you have become accustomed to guiding the material.

Material is moved along by the feeding foot only, and the direction of stitching can be changed as desired by turning handle, Fig. 5. To make a curved stitching, *operate machine slowly and without turning work*, turn the turning handle enough to produce the desired curve.

Feeding foot rises between each stitch while needle is in the material. With needle serving as pivot, material can be turned in any direction. When desired, the feeding foot may be fixed to feed in a straight line in any direction, by tightening the thumb screw shown in Fig. 5.

Never turn the work or alter the direction of the feed while the foot is pressing on the material, as this may cause skipped stitches and damage the surface of the work.

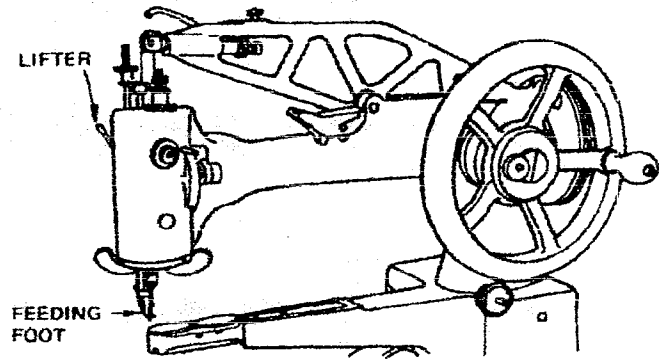

Fig. 4

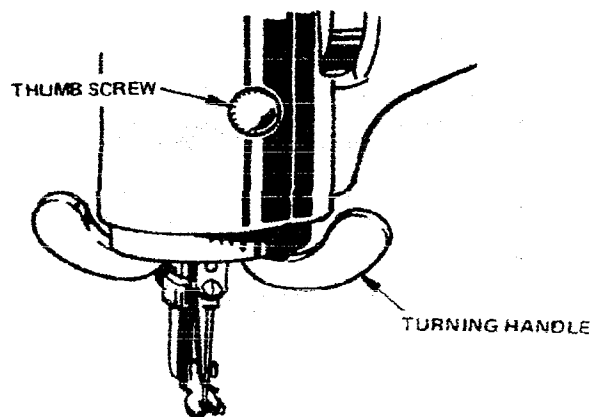

Fig. 5

## NEEDLES

Needles for Machines 29U171A, 29U172A and 29U173A are Cat. No. 3750.

The size of the needle to be used should be determined by the size of the thread which must pass freely through the eye of the needle. Rough or uneven threads, or threads which pass with difficulty through the eye of the needle will interfere with the successful use of the machine.

## THREAD

Left twist thread should be used in the needle. Either right or left twist thread can be used for the bobbin.

To determine the twist, hold the thread as shown. Turn the thread over toward you between the thumb and forefinger of the right hand; if left twist, the strands will wind tighter. If right twist, the strands will unwind.

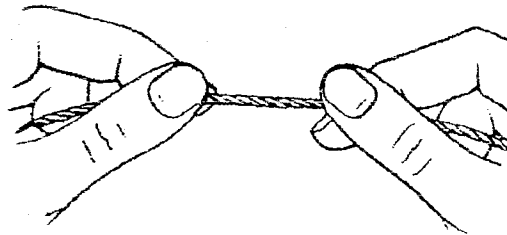

Fig. 6

## BOBBIN REMOVAL

Raise needle bar to its highest point and lift feeding foot shown in Fig. 7 by moving lifter shown in Fig. 5 upward.

Press down lever shown in Fig. 7 and swing needle plate around as shown.

Turn hand wheel until point of shuttle is nearest operator, then lift out shuttle with thumb and forefinger.

Turn shuttle over and the bobbin will drop out.

**NOTE:** For 29U172A machine, move bobbin retaining spring shown in Fig. 7 outward before taking out the bobbin.

## BOBBIN WINDING

Disengage hand wheel from stitching mechanism by drawing out plunger thumb nut shown in Fig. 8 and turning it slightly to left or right.

Place a spool of thread on the spool pin and pass end of thread through the center slot or hole in the bobbin. Then press the bobbin on bobbin winder spindle as far as it will go with the slot on the side of the bobbin facing the outside.

Loosen thumb screw shown in Fig. 8 on bobbin winder and push it down until the rubber ring presses against the rim of the hand wheel, then tighten screw.

Turn hand wheel over to the right (clockwise) as when sewing and simultaneously guide the thread with the finger as shown in Fig. 8.

**NOTE:** If hand wheel and bobbin winder are fitted at end of machine, the slot on the side of the bobbin is faced to the left. The top of hand wheel must then turn over toward you as when sewing to insure properly wound bobbins.

When bobbin is sufficiently full, remove it from the spindle. Loosen thumb screw shown in Fig. 8 on the winder and move screw upward in slot until the rubber ring is out of contact with the hand wheel, then tighten thumb screw.

Re-engage the hand wheel with the stitching mechanism by turning plunger thumb nut shown in Fig. 8 slightly while simultaneously turning the hand wheel slowly until the plunger enters the hole in the inner disc.

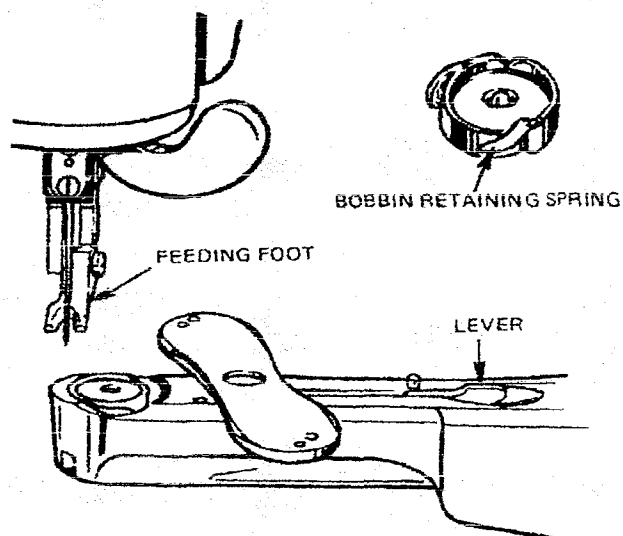

Fig. 7

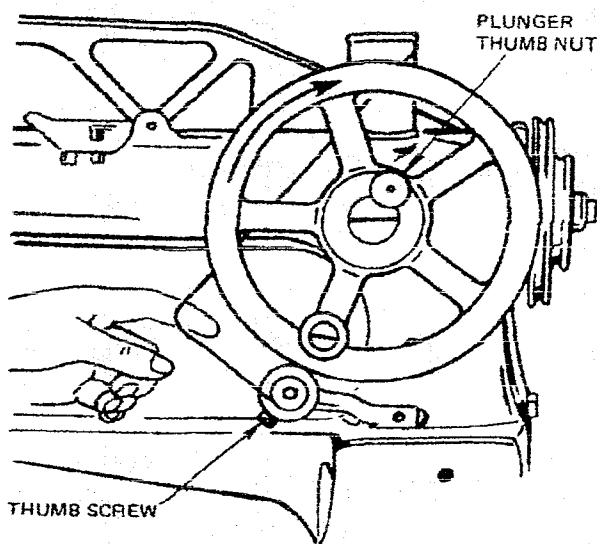

Fig. 8

## SHUTTLE THREADING

Hold the bobbin between the thumb and forefinger of right hand with the slot in the edge of the bobbin at the bottom. Allow two or three inches of thread to hang free.

Hold the shuttle in the left hand with the wide opening uppermost. Let end of thread pass through shuttle opening, then place bobbin into shuttle. See Fig. 9.

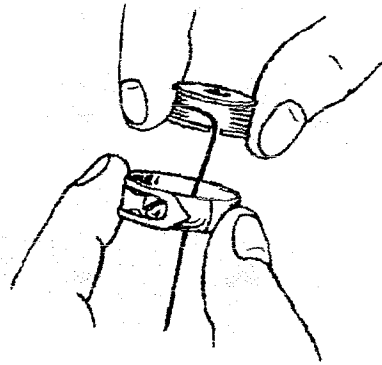

Fig. 9

Turn shuttle over while holding bobbin in it and draw the thread into the slot in the edge of the shuttle and under the end of the tension spring. See Fig. 10.

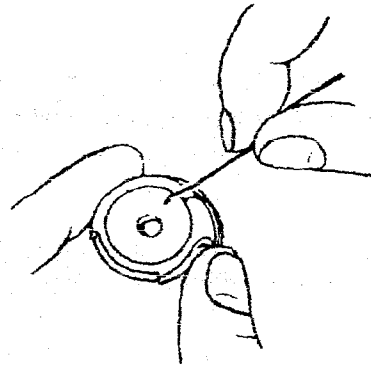

Fig. 10

Pass the thread through delivery eye which is in the upper edge of the shuttle. See Fig. 11.

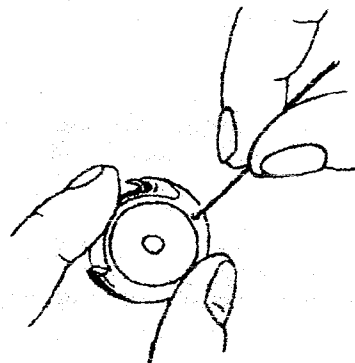

Fig. 11

## SHUTTLE THREADING 29U172A

Hold the bobbin between thumb and forefinger of right hand with the thread leading from right to left.

Hold the shuttle in the left hand with its open end up and its retaining spring moved outward. See Fig. 12.

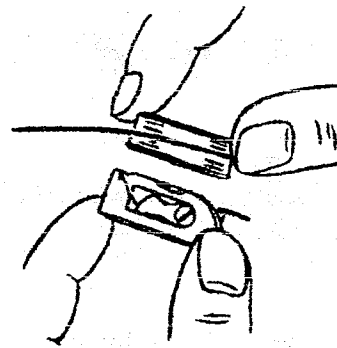

Fig. 12

Place bobbin into shuttle and push back the retaining spring which will hold the bobbin in the shuttle.

With the right hand, draw the thread into the slot in the edge of the shuttle as far as possible. See Fig. 13.

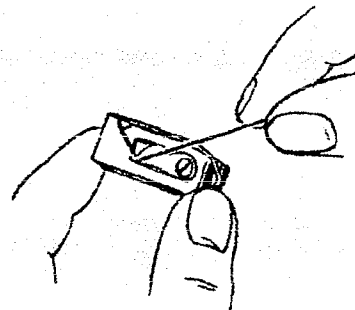

Fig. 13

Then draw thread to the left, up, and to the right under the spring. See Fig. 14.

Now insert end of thread up through the small hole in the edge of the shuttle and through the eye in top of the bobbin position post. See Fig. 15.

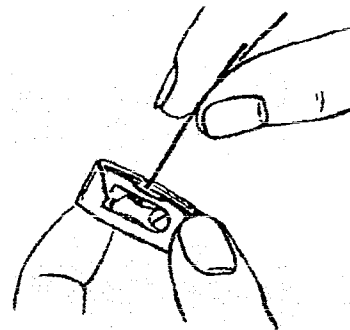

Fig. 14

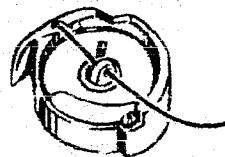

Fig. 15



## SHUTTLE REPLACEMENT

After threading the shuttle, turn hand wheel until the upright part of the shuttle carrier is to the right. Then with the point of the shuttle nearest you, and pointing towards the right, place into the recess as shown in Fig. 16. With needle bar at its highest point, press down lever shown in Fig. 16, and swing back needle plate to its sewing position.

## NEEDLE SETTING

Raise needle bar to its highest point and loosen needle clamping screw shown in Fig. 17. Then insert shank of the needle up into the needle clamp as far as it will go with long groove of the needle to the left and its eye directly in line with the arm of the machine. Tighten needle clamping screw showing in Fig. 17. Loosen needle bar clamping screw and move the needle bar clamp to right or left until the needle passes through the center hole in the needle plate, then tighten needle bar clamping screw.

**CAUTION:** There are two double end needle plates furnished with each machine. Be certain needle is straight and corresponds to the correct needle hole size indicated on end of needle plate.

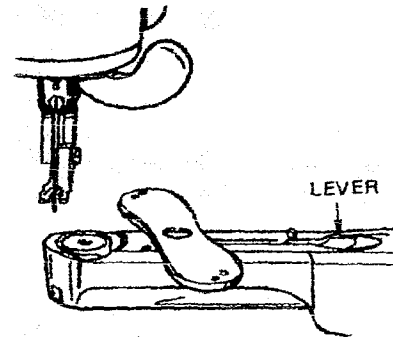

Fig. 16

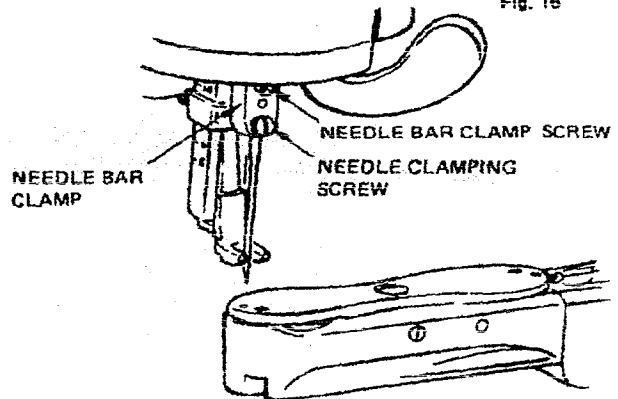

Fig. 17

## THREADING

1. Place the spool of thread on the spool pin so that thread will draw from the rear side of spool. See Fig. 18.

2. Raise the wire guide in the oil cup on top of the arm and pass thread under guide 1, then press guide back into position.

3. Draw the thread around back of pin 2 which is near the tension discs on top of the arm and from back to front and right to left between the tension discs 3. See Fig. 19.

4. Pass thread through wire eyelet 4.

5. Lead thread up and from front to back through the hole 5 in the take-up lever.

6. Draw about 10 inches of thread through the hole in take-up lever and insert the end into the slit in the end of the threading wire supplied with the machine. Then pass end of threading wire down through hole 6 which runs through the center of the needle bar.

7. Remove thread from threading wire then withdraw threading wire. Pass the thread from left to right through the eye of the needle 7. Draw about three inches of thread through the eye of the needle with which to start sewing.

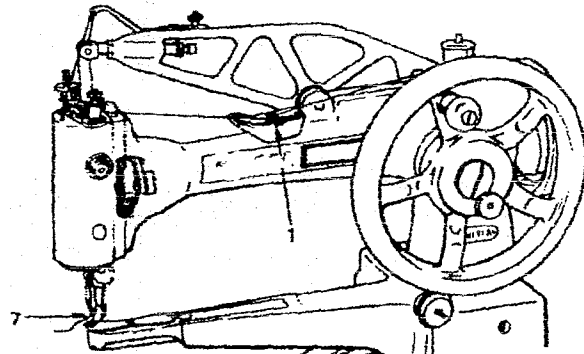

Fig. 18

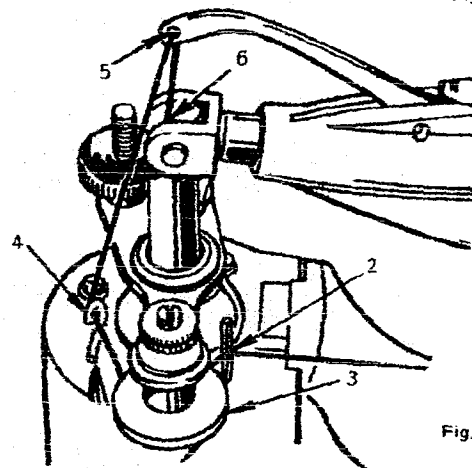

Fig. 19

## THREADING FOR DARNING

1. Place the spool of thread on the spool pin so that thread will draw from rear side of spool.
2. Raise the wire guide in the oil cup on top of the arm and pass thread under guide 1 then press guide back into position. See Fig. 20.
3. Pass thread over the pin 2 near the tension discs in front of the arm and from right to left under and between the tension discs 3, Fig. 22.
4. Pass thread through wire eyelet 4.
5. Pass thread up and from front to back through the hole 5 in the take-up lever.
6. Draw about 20 inches of thread through the hole in take-up lever and hang the middle on V notch on the end of the threading wire supplied with the machine. Then pass end of threading wire down through hole 6 which runs through the center of the needle bar.
7. Remove thread from threading wire then withdraw threading wire. Pass the thread from left to right through the eye of the needle 7. Draw about three inches of thread through the eye of the needle with which to start darning.

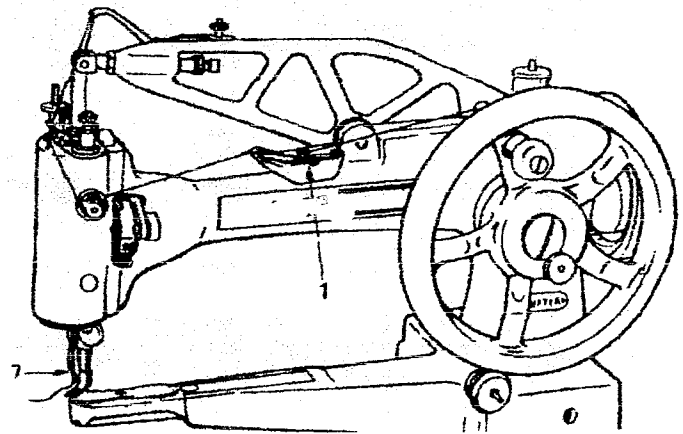

Fig. 20

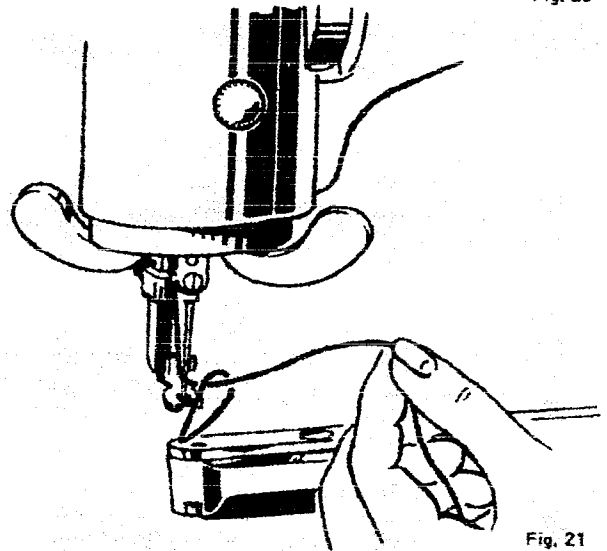

Fig. 21

## PREPARING FOR SEWING

With the left hand hold the end of the needle thread, leaving it slack from the hand to the needle. Turn top of hand wheel over toward the right (clockwise) until the needle moves down and up again to its highest point, thus catching the bobbin thread; draw up the needle thread and the bobbin thread will come up with it through the hole in the needle plate. See Fig. 21. Lay both threads back under the feeding foot.

**NOTE:** Turn top of hand wheel over toward you if hand wheel is fitted on side of machine.

## SEWING

Place the material under the feeding foot, lower the foot and start to sew, turning the hand wheel to the right. (Turn hand wheel over toward you if located on side of machine.)

**CAUTION:** Do not try to help feeding of the work by pulling the material as this may deflect the needle and cause it to break. The machine feeds the work easily without any assistance.

Let the needle bar rest at its highest point, raise the feeding foot, then draw the material backward about 3 inches (75mm) and cut the threads close to the work. Lay the ends of the threads under the feeding foot.

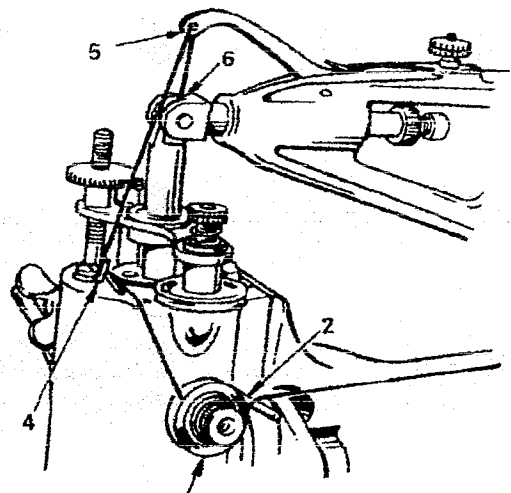

Fig. 22

## NEEDLE THREAD TENSION

The tension on the needle thread is regulated by the thumb nut near the tension discs. See Fig. 23.

To increase the needle thread tension, tighten thumb nut.

To decrease the needle thread tension, loosen thumb nut.

**NOTE:** Tension on needle thread can be tested only when the feeding foot is down.

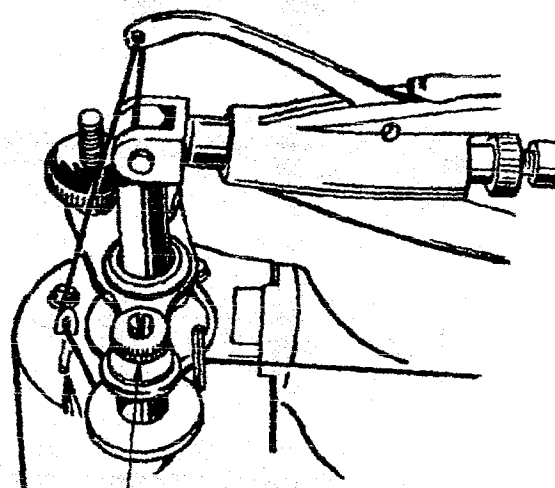

THUMB NUT

Fig. 23

## BOBBIN THREAD TENSION

The tension on bobbin thread is regulated by the screw in Figs. 24 and 25 on the end of the shuttle tension spring.

To increase bobbin thread tension, gradually tighten screw. See Fig. 24.

To decrease bobbin thread tension, gradually loosen screw. See Fig. 25.

When bobbin thread tension has been properly adjusted, it is seldom necessary to change it because a correct stitch can be usually obtained by varying the needle thread tension.

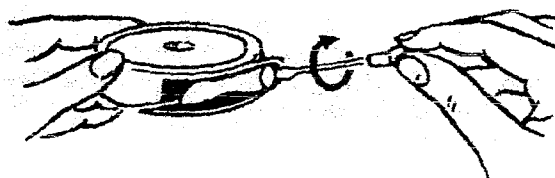

Fig. 24

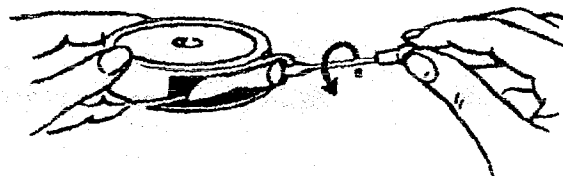
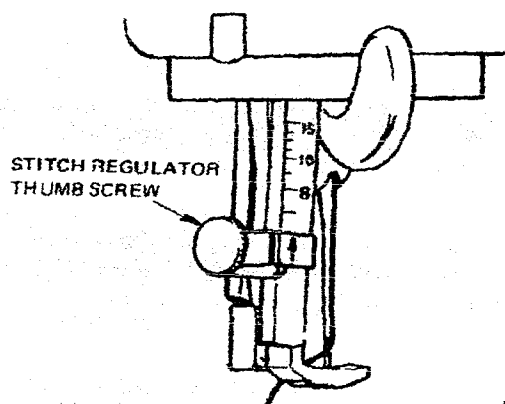

Fig. 25

## STITCH LENGTH REGULATION

The length of stitch is regulated by the stitch regulator which is held in position by stitch regulator thumb screw, Fig. 26 at back of the feeding foot bar. Loosen thumb screw and move the regulator up or down until its top is in line with the mark indicating desired number of stitches to the inch as shown by the arrow. Then tighten the thumb screw.



STITCH REGULATOR  
THUMB SCREW

Fig. 26

## REGULATING TAKE-UP LEVER TENSION

The spring tension on take-up lever shown in Fig. 27 is adjusted by tension stud nut. The tension on this lever should be about the same as that applied to the upper thread by the tension discs.

When the stitch is set, at the top of the needle bar stroke, take-up lever should be held down far enough by the tension of the thread so that the take-up action will keep the thread taut until the needle enters the work.

When sewing light weight materials with fine thread, more take-up action may be secured by turning the tension stud nut so that it screws up to decrease the take-up spring tension. This should be done instead of tightening the thumb nut of the tension discs.

For heavier materials and thread, the take-up tension must be about the same as that applied to the upper thread by the tension discs.

Other adjustments can be made in steps by turning the nut to suit any thickness of material and thread within the capacity of the machine.

**NOTE:** All machines sent out from the factory are so adjusted that they will give satisfactory results on a general range of materials. Before any adjustment is made to the travel of the take-up lever, the needle bar should be raised to its highest point.

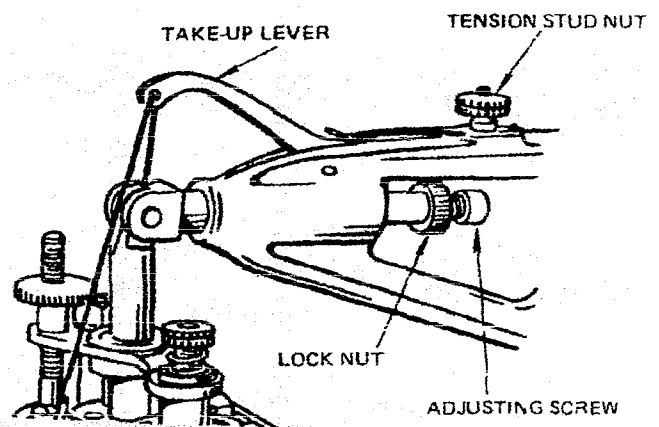

Fig. 27

## ADJUSTING TRAVEL OF TAKE-UP LEVER

The range of adjustment, when sent out from the factory, should suffice for all general purposes, but, if desired, the range can be raised or lowered by means of the adjusting screw Fig. 27 at the extreme right.

To alter the range, loosen the lock nut and, using a screwdriver, turn the adjusting screw to the right to reduce the travel of the take-up lever.

To increase the travel, turn the adjusting screw to the left. Wear at the tip of the center screw can also be taken up in this manner. When the proper adjustment has been obtained, tighten the lock nut.

It is most important that lock nut be securely locked against the face of the piston.

## REGULATING PRESSURE ON THE MATERIAL

The pressure on the material is regulated by adjusting nut shown in Fig. 28. To increase the pressure, tighten the adjusting nut. To reduce the pressure, loosen the adjusting nut.

Heavier pressure is required for leather work than for sewing cloth or cotton materials. The pressure should be only heavy enough to enable the feed to move the work along evenly.

## TURNING A CORNER

Stop the machine with the needle in the work and turn top of hand wheel over toward you until the feeding foot rises. Then turn the work as desired, using the needle as a pivot.

## REGULATING THE AUTOMATIC LIFT OF THE FEEDING FOOT

While the machine is in operation, the feeding foot rises after it has moved the work forward; then the foot moves toward the needle and descends again upon the fabric. It is advisable that the lift of the foot should be only sufficient to clear the thickest part of the work.

To adjust the lift, raise the feeding foot by means of lifter shown in Fig. 28. To increase the feeding foot lift, loosen clamping screw and move the screw toward you. To reduce the lift, move the screw away from you. When the desired height of lift is obtained, tighten the clamping screw.

## CHANGING DIRECTION OF THE FEED

While stitching, the work is moved along by the action of the feeding foot only.

The direction of the stitching can be changed as desired by turning the foot around by means of the two handles Fig. 29.

## CHANGING THE NEEDLE PLATE

1. Raise the needle bar to its highest position.
2. Loosen hinge pin binding screw shown in Fig. 30 and by lifting upward, remove needle plate and hinge pin.
3. When replacing the needle plate, place flat side of hinge pin toward hinge pin binding screw.
4. Tighten hinge pin binding screw on flat side of hinge pin.

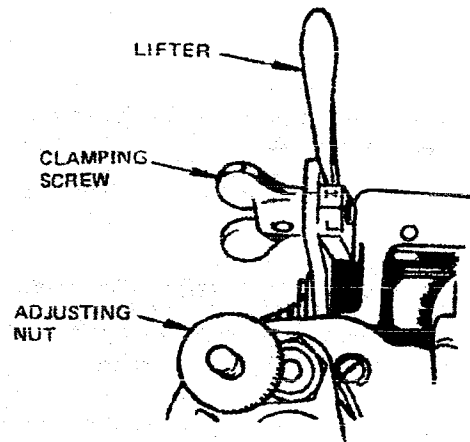

Fig. 28

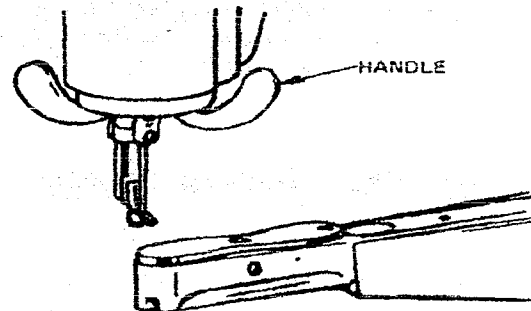

Fig. 29

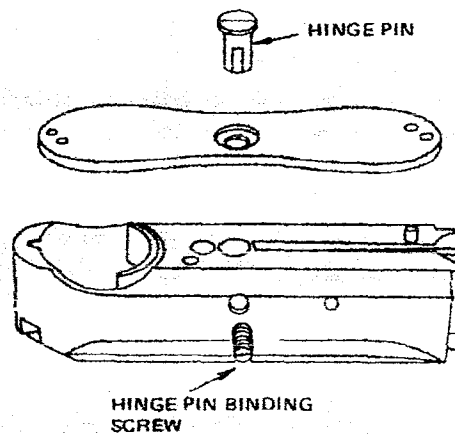

Fig. 30

## EXAMINATION FOR REMOVAL AND REPLACEMENT OF GEAR BOX

Remove machine from treadle stand or power bench after taking out the four screws located at the base of the machine. The machine should then be tilted back upon its machine pulley end, the underside facing the adjuster. Parts can be examined or removed from the rack box after taking out the two cover plate screws shown in Fig. 31 and removing the cover plate. The following parts are then exposed as shown in Fig. 32: long rack, short rack, shuttle following pinion, shuttle driving pinion, needle plate locating pin and spring, all of which can be removed without disconnecting the rack box from the machine.

To take out the shuttle carrier, remove the small set screw in the shuttle driving pinion by inserting a small screwdriver through the groove at the side of the rack box as shown in Fig. 32. The shuttle carrier can then be pressed through the pinion. To remove the long rack, insert a screwdriver through hole as shown in Fig. 33 and take out the hinge screw. Before proceeding to withdraw the rack, remove the shuttle following pinion then grip the rack and draw it straight toward the pulley end of the machine. The short rack and shuttle driving pinion can be removed without difficulty. When replacing any one or re-assembling the whole of these parts, care must be taken to see that the gears and racks are correctly engaged, as shown in Fig. 34.

### INSTRUCTIONS FOR REMOVAL OF THE GEAR BOX

If for any reason it is necessary to remove the rack box from the machine, proceed as follows: Remove the machine from its treadle stand or power bench. Turn the hand wheel until the connecting rod hinge screw, Fig. 33 is opposite the hole in the lower arm. Then tilt the machine back upon its machine pulley end, the underside facing the adjuster. Insert a screwdriver through the hole as shown in Fig. 32, and remove the screw. Slightly loosen the two gear box screws by giving them a half turn with a screwdriver. Then drive out the taper pin, using a 3/16" punch and hammer, and take out the two gear box screws. The machine should now be replaced on its feet and the horn will then come away if pulled in a horizontal direction.

**CAUTION:** Never raise the front of the horn or the end of the long rack may be damaged.

When re-assembling the box to the machine, be sure that the taper pin is driven in as far as it will go before finally tightening the two screws shown in Fig. 33.

**NOTE:** Cover plate is shown removed in Fig. 33 to illustrate how the gears and racks should be correctly engaged.

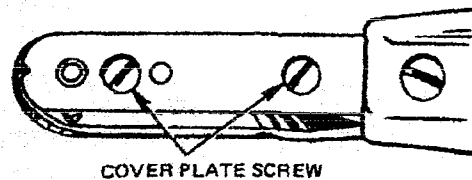

Fig. 31

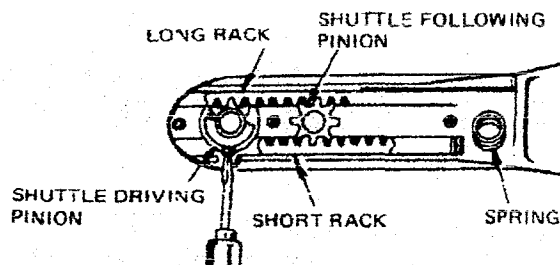

Fig. 32

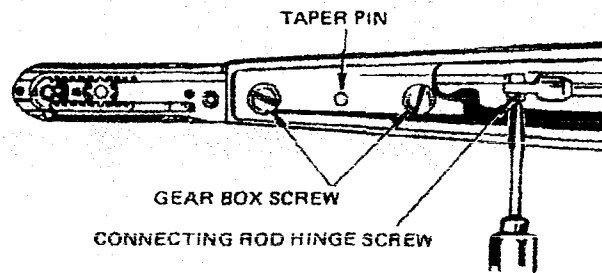

Fig. 33



Fig. 34

## SHUTTLE TIMING

Turn hand wheel until eccentric stud is aligned with screwdriver hole shown in Fig. 35.

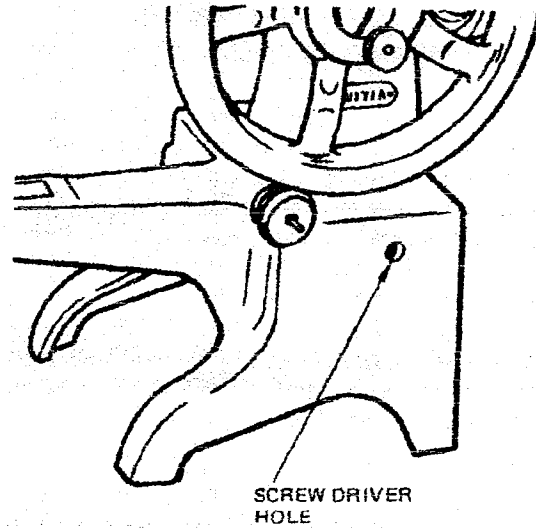

Fig. 35

To time the shuttle, turn eccentric stud at screwdriver hole until the leading edge of the shuttle carrier moves at each oscillation to a position approximately one-third the distance across the needle slot below the face plate as shown in Fig. 36.

**NOTE:** Shuttle is removed in Fig. 36 to illustrate correct timing of leading edge of shuttle carrier.

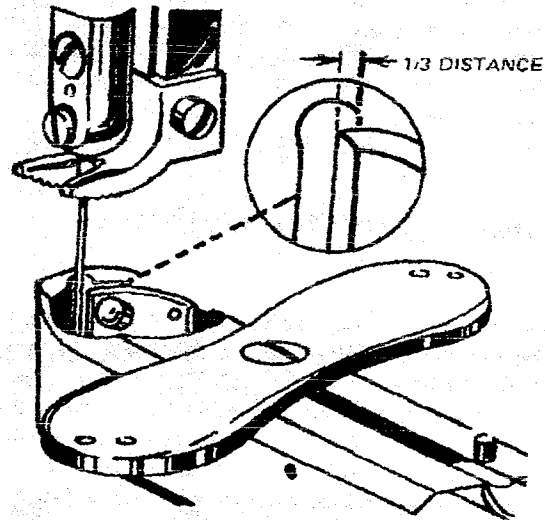

Fig. 36

## HINTS FOR PERFECT OPERATION

Oil the machine regularly.

The top of hand wheel must always turn over toward the operator (counterclockwise). If located at side of machine, the hand wheel must turn over from left toward right (clockwise).

Never run the machine without material between the feeding foot and needle plate.

Do not run the machine when both shuttle and needle are threaded unless there is material under the feeding foot.

### The Belt

See that the belt is not too tight; it should be just tight enough not to slip. If too loose, remove the hook at one end, shorten the belt and rejoin.

### Machine Working Heavily

If the machine runs hard after standing idle for some time, use a little kerosene or benzine in the oiling places, run the machine rapidly, then wipe clean and oil.

### To Avoid Breaking Needles

The feeding foot should be securely fastened by the thumb screw. Do not sew heavy seams or very thick material with too fine a needle. A large needle and thread to correspond should be used on heavy work. See page 4.

Avoid pulling the material when stitching. This may cause the needle to strike on the needle plate and break.

### Breaking of Upper Thread

Improper threading of machine.

Tension being too tight.

The thread being too coarse for the size of the needle.

The needle being bent, having a blunt point, or being set incorrectly.

### Breaking of Under Thread

Improper threading of shuttle.

Bobbin thread tension being too tight.

### Skipping of Stitches

The needle may not be accurately set into the needle bar or the needle may be blunt or bent.

Remove the accumulation of dirt or lint which might gather behind thread retaining spring near bottom of needle bar by working a piece of tape or thread back and forth between spring and needle bar.

**CAUTION:** Do not bend spring away from needle bar or spring may become permanently damaged.

Examine feeding foot and remove any dirt or lint from the teeth to insure regular feeding of material.

### Working on old, hard leather

When working on old, hard leather, it is advisable to soften the leather with oil, use a coarse needle and make a long stitch to prevent needle from splitting the leather.



9101-9124	<b>SHAFT , CAM WHEEL, SHUTTLE DRIVING LEVER, PULLEY WHEEL AND SHUTTLE DRIVING LEVER CONNECTING ROD ASSEMBLY</b>	9213 Cup (release).	9401-9422	<b>CHECK LEVER AND NEEDLE BAR COMPLETE</b>	9509 Stitch Regulator Thumb Screw.	9701-9712	<b>HAND WHEEL AND STOP MOTION COMPLETE</b>	
9101	Shuttle Driving Can and Gear.	9214 Disc (2).	9402	Check Lever.	9510 Roller and Stud.	9701	Hand Wheel and Stop Motion complete.	
9102	Shaft.	9215 Washer (leather).	9403	Joint Pin.	9511 Slide Bar .	9702	Nut .	
9103	Pin.	9216 Friction Spring Pin.	9404	Piston Joint.	9512 Revolving Bush.	9703	Binding Screw (2).	
9104	Gear.	9217 Head of machine.	9405	Washer Screw (2).	9513 Joint Screw (2).	9704	Hand Wheel Stop Motion Flanged Bushing.	
9105	Shuttle Driving Can.	9218 Thread Guide Pin (side).	9406	Head Revolving Bush Supporting Washer.	9514 Revolving Bush Handle.	9705	Spring.	
9106	Screw.	9219 Head Revolving Bush Stop Thumb Screw.	9407	Check Lever Thread Take-up Adjusting Screw With Indicator Complete.	9515 Handle Screw.	9706	Stop Motion Plunger.	
9107	Needle Bar/Cam and Pulley Wheel.	9220 Adjusting Stud (side).	9408	Lock Nut.	9516 Bell Crank Lever.	9707	Hand Wheel.	
9108	Feed motion Cam Wheel.	9221 Disc (2).	9409	Index Head.	9517 Gb.	9708	Plunger Thumb Nut.	
9109	Cam Wheel Pin.	9222 Tension (side) Spring.	9410	Index Head Stop Pin.	9518 Stitch Regulator.	9709	Handle (wood).	
9110	Poller.	9223 Head Binding Screw (4).	9411	Adjusting Screw.	9601-9629	<b>NEEDLE PLATES , GEAR BOX AND SHUTTLE COMPLETE</b>	9710	Spindle.
9111	Shaft Bushing.	9224 Slide Rod Lock Nut (upper).	9412	Locating Plunger.	9602	Needle Plate (fine and medium needle holes).	9711	Retaining Screw.
9112	Roller Pin.	9225 foot Bar Revolving Joint Bearing.	9413	Spring.	9603	Shuttle complete.	9712	Plunger Stop Screw.
9113	Roller and Stud.	9226 Hinge pin.	9414	Indicator Body.	9604	Bobbin.		
9114	Bearing Screw.	9227 Lock nut (lower).	9415	Indicator Body Lock Nut, Needle Bar Complete.	9605	Shuttle Body.	9801-9808	<b>BOBBIN WINDER COMPLETE</b>
9115	Shuttle Driving Lever.	9228 Slide rod.	9416	Needle Bar Complete.	9606	Tension Regulating Screw.		
9116	Eccentric Stud Nut.	9229 Lifter.	9417	Spring Screw (2).	9607	Tension Spring.	9801	Bobbin Winder complete.
9117	Cam and Pulley Wheel Set Screw.	9230 Hinge Screw.	9418	Thread Tension spring.	9608	Shuttle.	9802	Frame Screw.
9118	Shuttle Driving Lever Connecting Rod Complete. Nos.		9419	Needle Bar.	9609	Spring.	9803	Spindle.
9119	Connecting Rod End (front).	9301 Stud Nut.	9420	Needle Bar Clamp.	9610	Spring Screw.	9804	Frame.
9120	Pin (front).	9302 Spring.	9421	Needle Clamping Screw.	9611	Gear Box.	9805	Eccentric.
9121	Connecting Rod.	9303 Spring Stud.	9422	Clamp Screw.	9612	Pinion Bushing.	9806	Eccentric Thumb Screw.
9122	Pin (back).	9304 Needle Bar Driving Lever.			9613	Rack (short).	9807	Pulley.
9123	Connecting Rod End (back).	9305 Spring Stead Pin.			9614	Pinion Screw.	9808	Rubber Ring.
9124	Eccentric Stud.	9306 Spool Pin.			9615	Driving Pinion.		
9201-9230	<b>HEAD OF MACHINE AND TENSIONS COMPLETE</b>	9307 Cam Roller And Stud.	9501-9510	<b>FOOT BAR AND FOOT BAR REVOLVING JOINT</b>	9616	Rack (long).		
9201	Screw.	9308 Joint Pin.	9502	Adjusting Nut.	9617	Pinion cover Plate.	9851-9863	<b>ACCESSORIES</b>
9202	Thread Eyelet (head of arm).	9309 Oil Cup Screw.	9503	Spring Bar.	9618	Plate Screw (2).		
9203	Friction Spring.	9310 Oil Cup With 8597 and 8695.	9504	Vibrating Presser Spring.	9619	Needle Plate (medium and coarse needle holes).		
9204	Clamping Screw.	9311 Spring.	9505	Foot Bar.	9620	following Pinion Stud.	9851	Oiler.
9205	Lifting Lever Shaft Lever.	9312 Oil Pad (cloth).	9506	Collar Screw.	9621	Gear Box Position Pin.	9855	Screw Driver (machine).
9206	Lifting Lever Shaft.	9313 Vibrating Presser Lifting Lever (for medium work).	9507	Spring Bar.	9622	Releasing Lever Hinge Pin.	9856	Screw Driver (shuttle tension).
9207	Lifting Lever Shaft Adjusting Lever.	9314 Lifting Lever Screw.	9508	Feeding Foot Screw.	9623	Releasing lever.	9857	Machine Screw (for fastening machine to Power Table) (4).
9208	Clamping Screw.	9315 Thumb Screw.	9508	Feeding Foot.	9624	Locating Plunger.		
9209	Hinge Screw.	9320 Arm Side Cover (back).			9625	Needle Plate Hinge Pin Binding Screw.	9859	Machine Screw (for fastening Machine to Stand) (4)
9210	Tension Thumb Nut(2).	9321 Hand Wheel Hub Complete. Nos. 11663, 81869, 82008 and 82052			9626	Plunger Spring.		
9211	Tension Spring.	9322 Hand Wheel Shaft Gear.			9627	Following Pinion.		
9212	Adjusting Stud(top).	9323 Gear Pin.			9628	Gear Box Screw (2) .	9863	Threadin
		9324 Shaft.			9629	Connecting Rod Hinge Screw.		
		9325 Hub.						

