

ARTISAN®

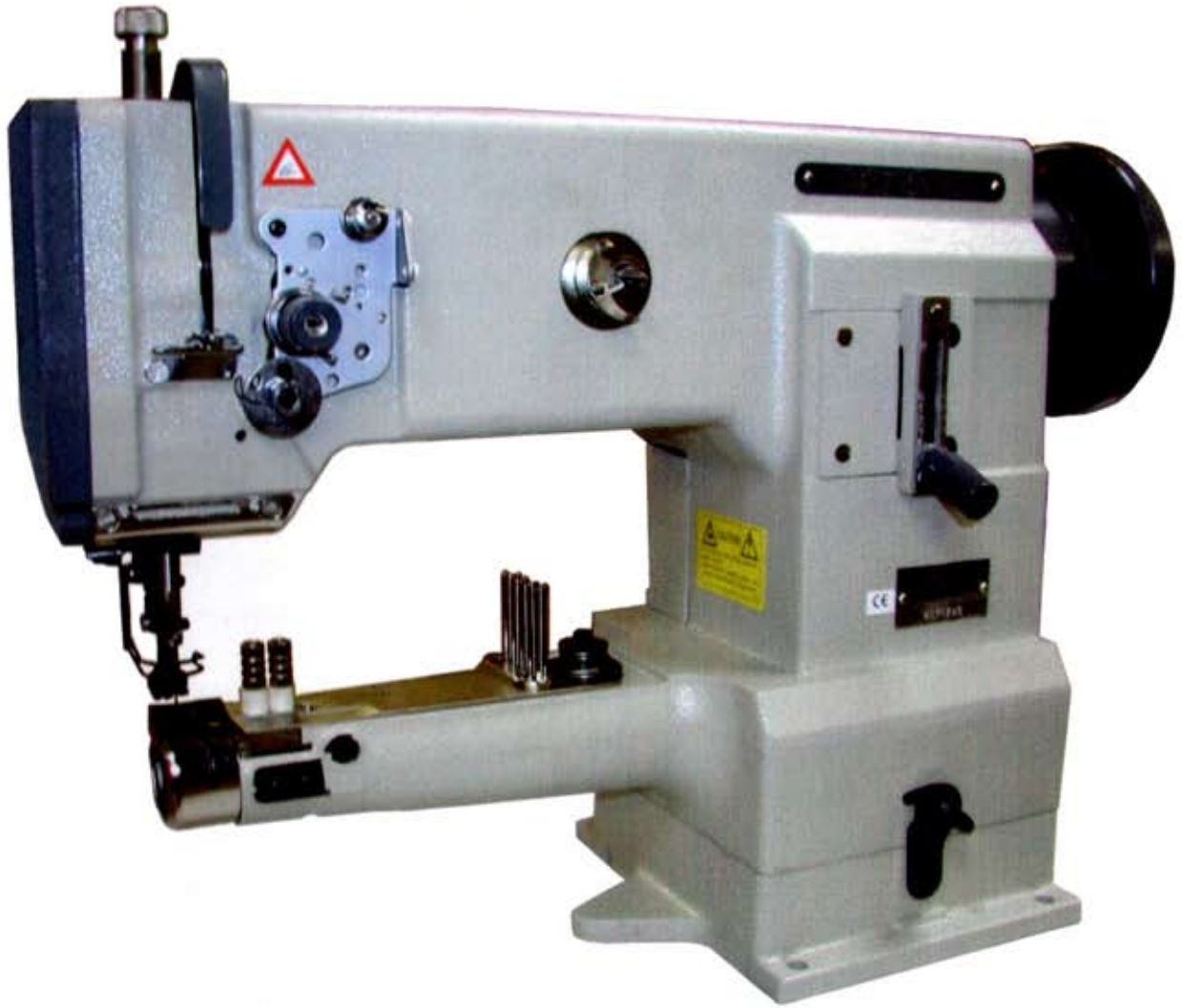

2698-1

**Operators Manual
and
Spare Parts List**

1 Safety

(1) Guidelines

The machine conforms to the following European regulations:

EN60204-31: 1996, 98/37/EC, DIN5310, DIN5318, 73/23/EEC
(93/68/EEC)

Current general, legal and other rules and regulations as well as current environmental protection requirements should also be considered in addition to this instruction manual. Current local trade union safety regulations or regulations of other supervisory authorities must always be observed.

(2) General Safety Tips

1) The machine should only be used after studying the accompanying instruction manual and only by specially instructed operating staff.

2) Before bringing the machine into service read the safety tips and the instruction manual of the engine manufacturer.

3) The machine may only be used according to their regulations and not without the accompanying protective fittings. All relevant safety regulations should also be observed.

4) When changing sewing tools (for example needle, presser foot, needle plate and bobbin winder), when threading up, when leaving the work place as well as during maintenance work the machine should be unplugged or switched off at the main switch.

5) Daily maintenance work should only be carried out by specially trained personnel.

6) Repair work as well as special maintenance work should only be carried out by skilled workers or specially trained personnel.

7) Working on the electrical equipment should only be carried out by qualified electricians.

8) Working on active parts and equipment are not permitted.

9) Alterations to the machine should only be made in accordance with all relevant safety regulations.

10) It is forbidden to bring the top part of the machine into service until it has been verified that the whole sewing machine conforms to the requirements.

11) Only the spare parts provided by us should be used during repairs. We explicitly point out that the spare parts and accessories that are not

supplied by us are also not tested or passed by us. The installation or use of such products can in certain circumstances reduce the predetermined quality of your machine. We take no responsibility for damage caused by the use of non-original parts.

(3) Important Points for the Employer

1) This instruction manual is a component of the machine and must always be at the disposal of the machine operators. It is necessary to read the manual before using the machine for the first time.

2) Operation and maintenance personnel must be instructed on safety features of the machine and safe working methods.

3) The employer must ensure that the machine is only used if it is in perfect condition.

4) The employer should make sure that safety guidelines are not ignored or countermanded.

5) The employer should make sure that only authorised persons are permitted to work on the machine.

Further information can be obtained from the responsible sales office.

(4) Service and Technical Personnel

1) Service Personnel

Service personnel are responsible for the preparing, running and cleaning of the machine as well as the elimination of faults in the sewing. Service personnel must observe the following points:

① to follow the safety guidelines in the instruction manual

② to avoid any type of work which may reduce the safety of machine

③ to wear tight-fitting clothes and avoid wearing jewellery, like necklaces and rings

④ to ensure that only authorised people work on the machine

⑤ to report immediately changes in the machine which may reduce safety to the employer.

2) Technical Personnel

Technical personnel are responsible for the lubrication, maintenance repair and adjustments to the machine. Technical personnel must observe the following points:

① To follow safety guidelines in the instruction manual

② Before beginning maintenance work the main switch must be switched off and it must be ensured that it will not be switched on again.

③ Working on active parts and equipment is not permitted.

④ After repair and maintenance work the protective covering must be put back and the electric control box must be closed.

5) Danger Tips (Fig.1)

① During operation a space of 1m in front of and behind the machine should be maintained so that unrestricted access is possible.

② During sewing do not reach into the needle area! Be careful of the danger of injury from the needle.

③ During operation do not leave objects lying on the table or in the needle plate tongue. Objects can get jammed or knocked away. Danger of injury will result.

④ With mechanically operated clutch motors without operation barriers, operators should wait for the motor to stop. Danger of injury will result.

⑤ Do not use the machine without the thread take-up cover 1! Danger of injury from the movement of the threader will result.

⑥ Do not use the machine without the finger guard 2! Danger of injury from the outward and upward movement of the needle will result.

⑦ Do not use the machine without the lifting arm cap 3! Danger of injury from the rotating arm will result.

⑧ Do not use the machine without the belt cover 4! Danger of injury from the rotating belt will result.

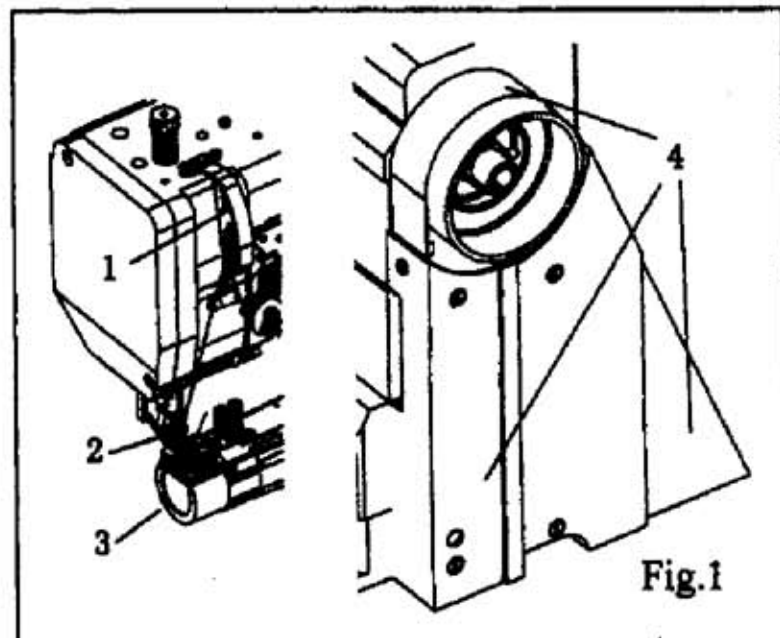

2 Correct Use According to the Regulations

Every use not approved by the manufacturer is not in accordance with the regulations. The manufacturer is not responsible for damage which result from unregulated use. Accordance with the regulations includes the previously stated service, installation, maintenance and repair measures.

3 Technical Data

Max. sewing speed (rpm)	2200
Needle size	DP X 35LR 12#-16#
Max. Stitch Length (mm)	6

4 Disposal of the Machine

- (1) Proper disposal of the machine is the responsibility of the customer.
- (2) The materials used in this machine are steel, aluminium, brass and diverse plastics.
- (3) The electrical fittings are made out of plastics and copper.
- (4) The machine should be disposed of in accordance with current local environmental regulations.

It should be ensured that those parts tainted with lubricant are disposed of separately in accordance with current local environmental regulations.

5 Transport Packaging and Storage

(1) Transport within the customer site

Transport within the customer site is not the responsibility of the manufacturer. It should be ensured that the machine is correctly transported

(2) Disposal of the Packaging

The packaging of this machine consists of wood, paper, cardboard and polystyrene. The packaging should be disposed of by the customer in accordance with the regulations.

(3) Storage

The machine can be stored unused for up to 6 months. It should be protected against dirt and moisture. If the machine is to be stored longer, the individual parts, in particular the sliding plates, should be protected against corrosion, with an oil film for example.

6 Installation & First Operation

The machine should only be installed and started by qualified technical personnel. All the relevant safety regulations should be observed. Suitable electricity supply must be available at the installation site (see technical data). It must be ensured that there is an even and solid ground surface as well as sufficient lighting at the installation site.

(1) Installation

1) Assembling the Sewing Light

Attach the sewing light to the table plate (wood screws 5 × 35) and let technical personnel switch it on.

2) Assembling the Bobbin Stands

① Assemble the bobbin stands

② Place the bobbin stands in the drill hole in the table plate and fix them into place with the enclosed nuts.

(2) First Operation

Before the first operation check the electric cables in case of any possible damage.

1) Clean and oil the machine thoroughly

2) Allow technical specialists to check whether the machine's motor may be connected to the available main supply and whether it is properly plugged in. If there is any deviation, do not start the machine.

3) When the machine is running the balance wheel should be turned towards the operator. Otherwise let technical specialists adjust the motor.

(3) Switching the Machine On / Off

1) Switch on the machine

2) Do a test run.

The sewing light is not included in a standard delivery.

7 Preparation

1) All regulations and guidelines in this manual should be observed, with special attention being paid to safety regulations.

2) All preparation work may only be carried out by specially instructed personnel. Before all preparation work the machine should be disconnected from the main electricity supply by switching off the main switch or unplugging it.

(1) Needle and Thread

The choice of the right needle depends on the model of the machine as well as the thread and material to be used.

(2) Attaching the needle (Fig.2)

- 1) Switch off the machine!
- 2) Loosen needle-holding screw 1
- 3) Put the needle in as far as it will go (the long needle groove should point to the left)
- 4) Tighten needle-holding screw 1

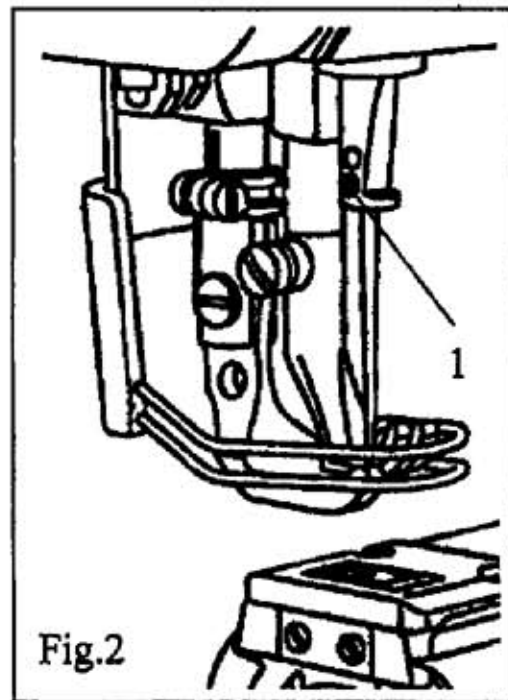

Fig.2

(3) Winding the lower thread, regulating the tension of the thread (Fig.3)

- 1) Put an empty bobbin onto the bobbin shaft 1 and thread the thread according to Fig 3
- 2) Push the bobbin catch in the direction of the arrow
- 3) The bobbin is filled during the progress of the sewing.
- 4) The bobbiner stops automatically when the bobbin is full.
- 5) The tension of the thread on the bobbin can be adjusted with knurled screw 2.

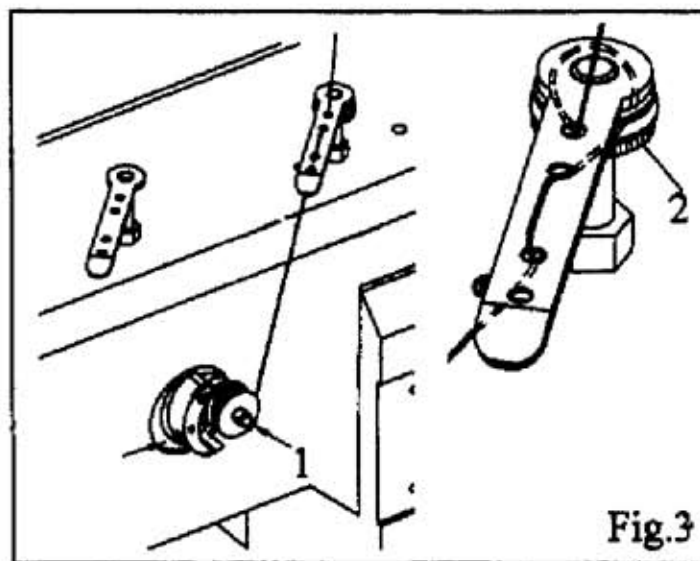

Fig.3

(4) Taking out the bobbin capsule / threading up (Fig.4)

Switch off the machine.

Take the bobbin capsule out.

1) Lift up handle 1 and take out bobbin capsule 2. Thread the bobbin capsule.

2) Thread the bobbin according to Fig 4

3) The bobbin should point in the direction of the arrow when taking up the thread.

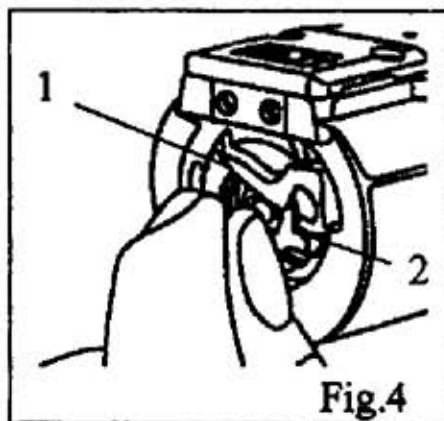

(5) Putting the bobbin capsule into place / regulating the tension of the lower thread (Fig.5)

Switch off the machine.

Put the bobbin capsule into place.

1) Put in bobbin capsule 2 so that it engages clearly.

Regulate the tension of the lower thread.

2) Regulate the tension of the lower thread with screw 3.

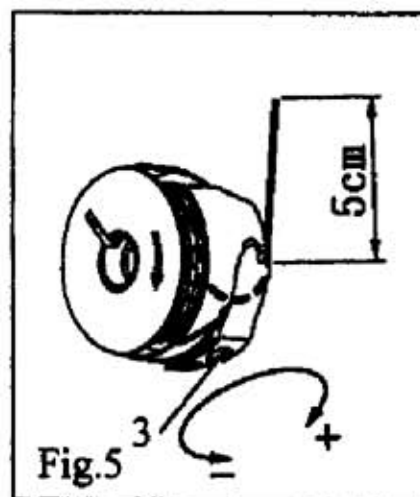

(6) Regulating the tension of the upper thread (Fig.6)

Regulate the tension 1 so that the stitches tie together in the sewing material.

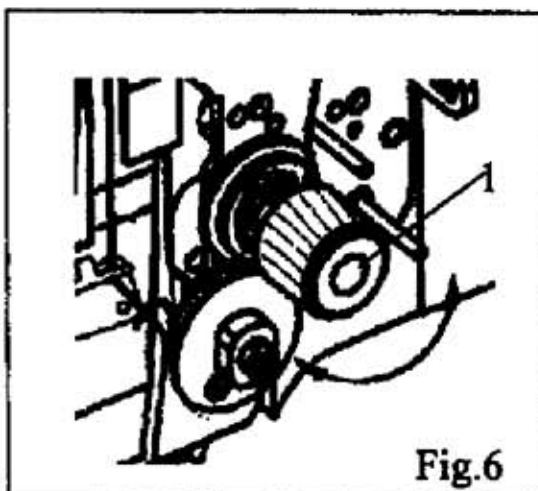

(7) Routing the upper thread (Fig.7)

Switch off the machine.

Route the machine according to fig 7. The needle should be routed from the left (see arrow).

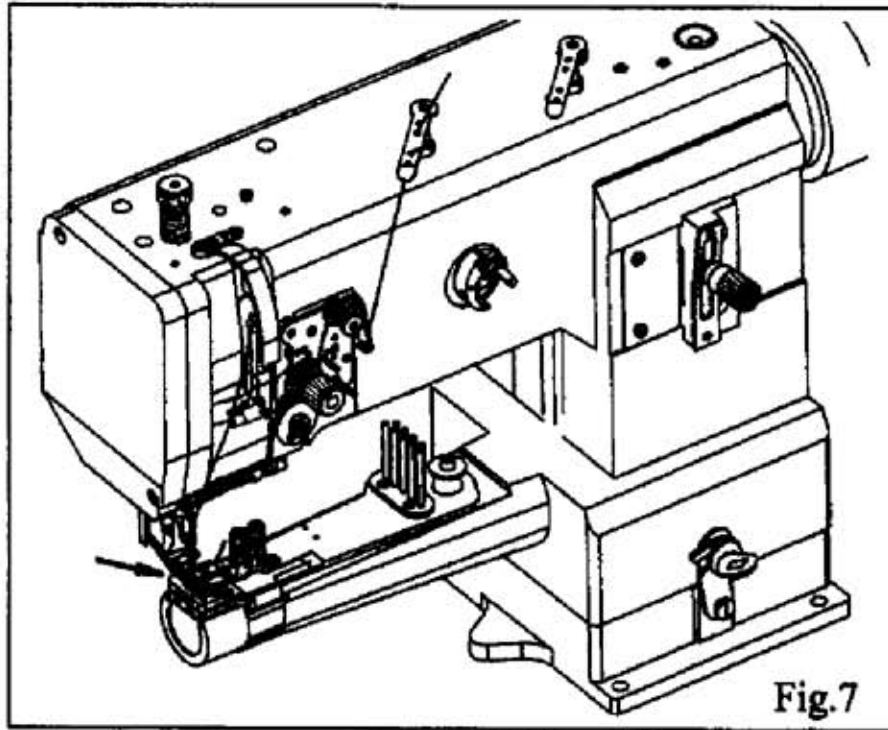

Fig.7

8 Stitch Length Adjusting Lever / Reverse Sewing (Fig.8)

1) Adjust length of stitches by turning the knurl nut 1

2) Reverse Sewing

Push the knurl nut 1 up as far as it will go (position R)

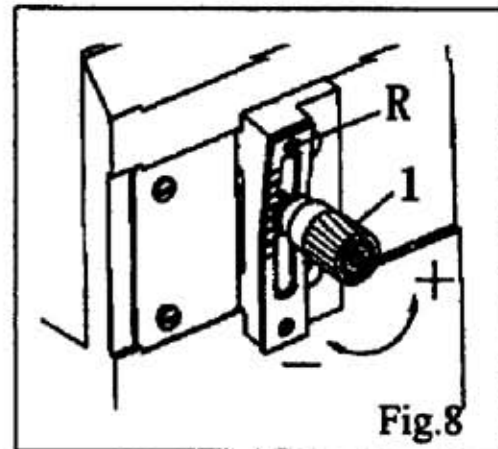

Fig.8

9 Maintenance & care

(1) Maintenance and care intervals

- 1) Cleaning - daily, more often with constant use.
- 2) General oiling - twice weekly.
- 3) Oiling of the head - twice weekly.
- 4) Oiling of the rotating hook - daily.

(2) Cleaning

Switch off the machine!

- 1) Clean the rotating hook and rotating hook area daily, more often with constant use.
- 2) Bring the needle bar to its highest position and remove the free arm cap.
- 3) Take out the bobbin capsule and bobbin.
- 4) Unscrew capsule holder piece .
- 5) Take out screw and lift up the rotating hook handle .
- 6) Turn the balance wheel until point stands at the same height as rotating hook point .
- 7) Take out the lower capsule and clean the rotating hook path with petroleum.
- 8) Put it back together in reverse order of the above. Make sure that the nose on the back of the capsule holder piece meshes with groove .
- 9) Unscrew rotating hook handle and put in the bobbin capsule with bobbin.
- 10) Draw back the freearm cap.

(3) General oiling (Fig.9, Fig.10)

Use white spindle oil.

- 1) Oil all the bearing positions shown in Fig 9 and 10 twice weekly.

Danger of being crushed between the top part and the base!

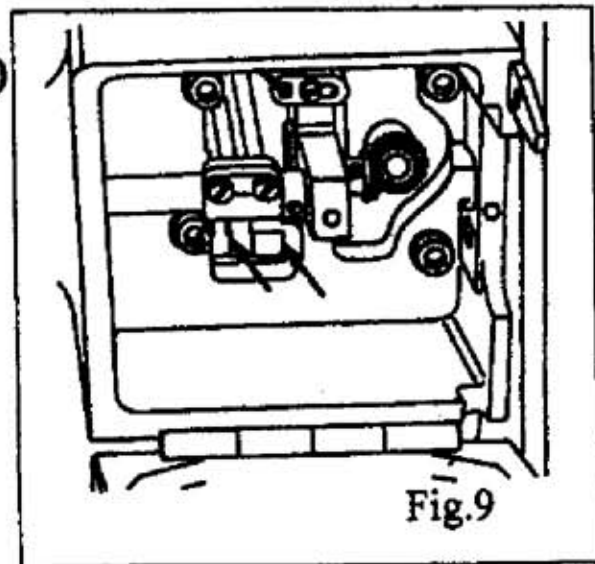

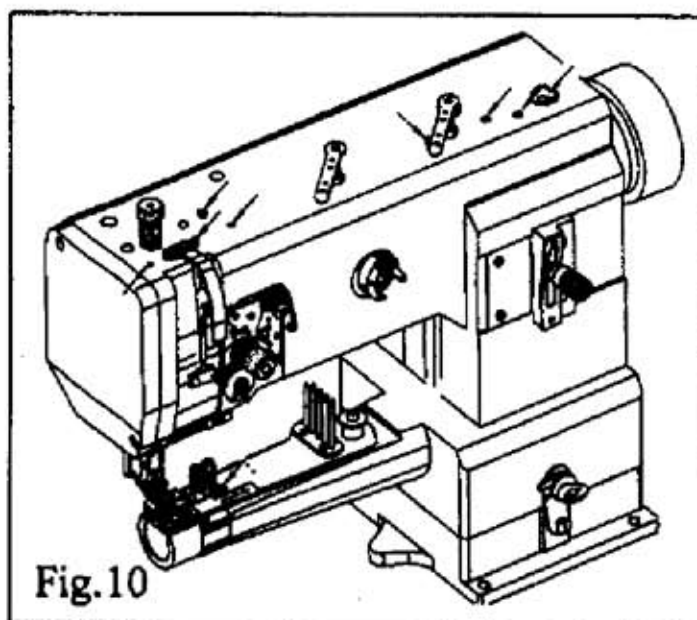

Fig.10

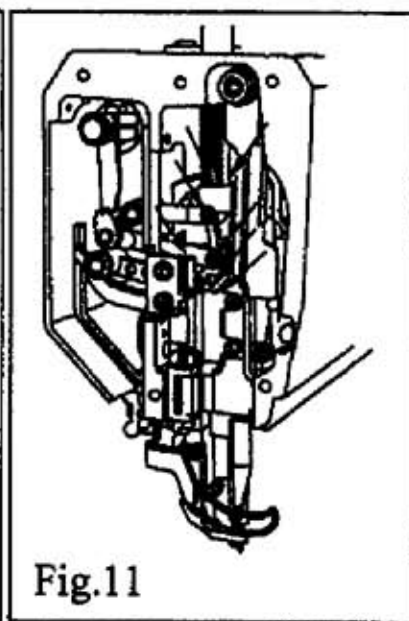

Fig.11

(4) Oiling the head (Fig.11)

Switch off the machine!

1) Take off the cover and oil all the bearing and sliding positions shown in fig 11 twice weekly.

2) Then screw the cover back on.

Use white spindle oil.

(5) Oiling the Rotating hook (Fig.12)

Switch off the machine!

1) Take the bobbin capsule out and drip one or two drops of oil into the rotating hook path (fig 12) once daily.

2) Then put the bobbin capsule back in.

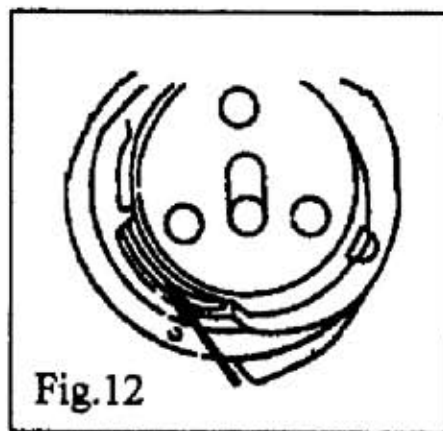

Fig.12

10 Adjustment

(1) Tips for adjustment

1) All adjustments in this manual apply to a completely assembled machine. Covers which have to be unscrewed and screwed on again for adjustment work are not mentioned in the text.

2) The screws or nuts mentioned in brackets are to be loosened before adjustments and tightened again afterwards.

(2) Adjustment of the basic machine

1) Position of the feed dog

① Positioning the feed dog at an angle to the direction of sewing (Fig.13)

The feed dog 1 should be the same distance right and left from the needle plate.

Move the feed dog 1 (screws 2) according to the above rule.

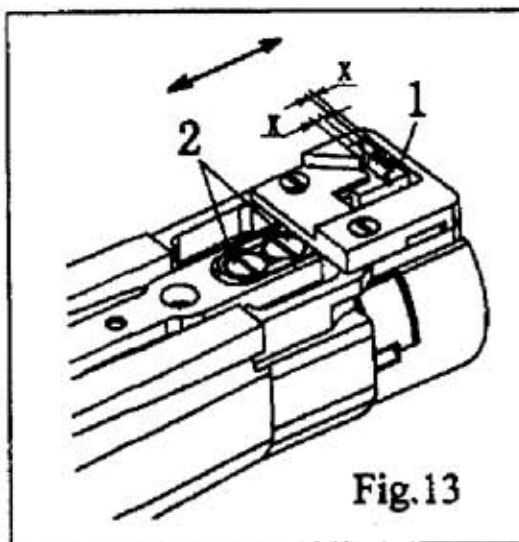

Fig.13

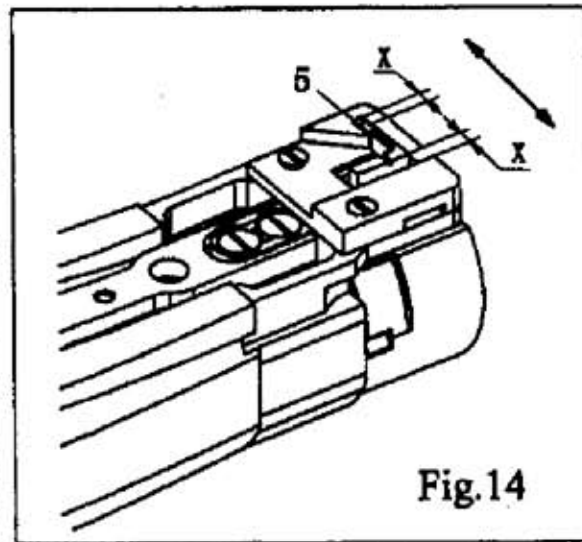

Fig.14

② Positioning the feed dog in the direction of sewing (Fig.14 Fig.15)

The feed dog 5 should keep the same distance in front and behind the needle plate when moving backwards and forwards when adjusting the maximum stitch-length.

I) Adjust the maximum stitch-length.

II) Push the crank 1 (screws 2) as far as possible to the left on the crank-area 3. The left screw must still be on the crank-area.

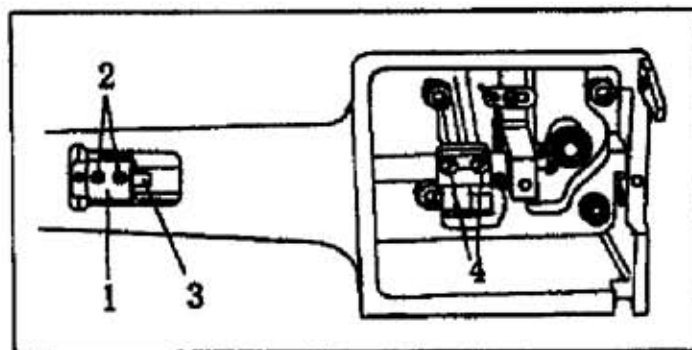

Fig.15

III) Loosen screws 4

IV) Move the feed dog 5 according to the rule.

V) Tighten screws 4.

2) Needle in the middle of the stitching hole (Fig.16

With the length of the stitch at '0' the needle should pierce exactly in the middle of the needle plate hole.

- 1) Unscrew the presser foot 1 and the walking foot 2.
- 2) Adjust the stitch-length to '0' and bring the needle bar to upper position.
- 3) Insert a new needle, loosen screws 3, 4, 5 & 6.
- 4) Bring the needle immediately over the feed dog by turning the balance wheel.
- 5) Move the needle bar 7 according to the rule.
- 6) Tighten screws 3, 4 & 5.
- 7) Bring stop 8 up to the needle bar area 7 and tighten screw 6.

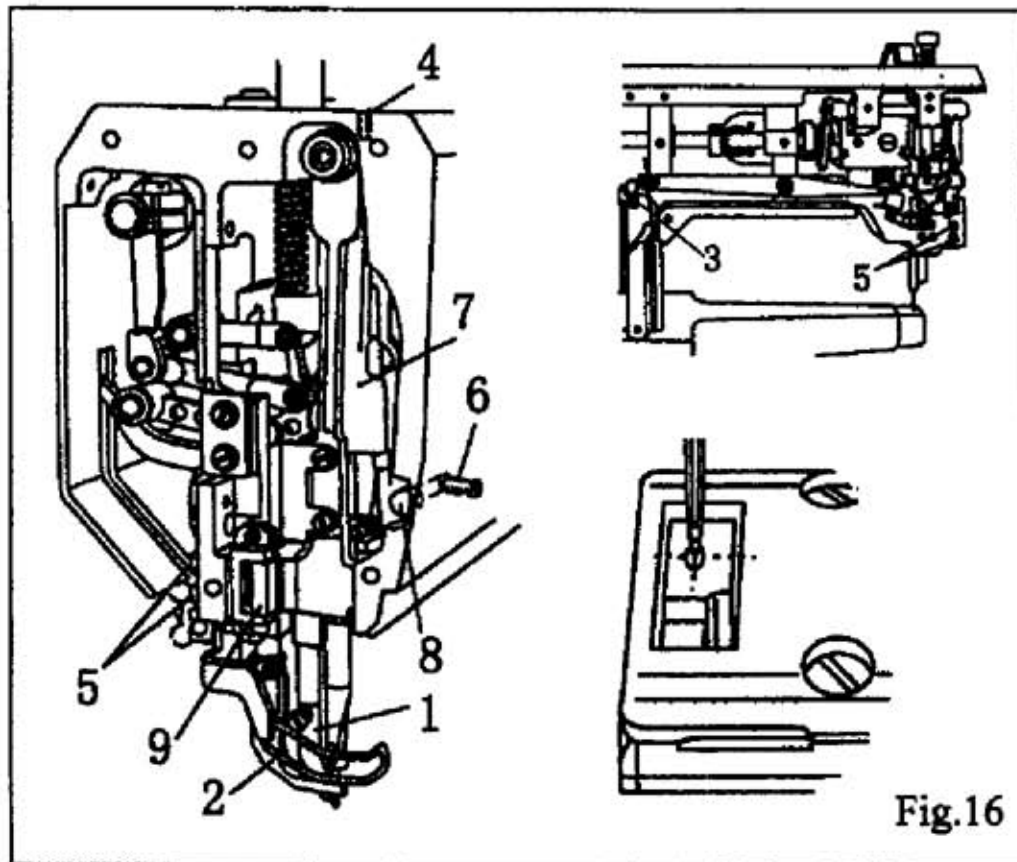

Note:

The needle bar 7 in guide 9 and the needle rock frame should move easily.

3) Needle height (pre-adjustment) (Fig.17)

When the needle bar is in lower position the distance between the needle bar and the needle plate should be 15mm.

Move needle bar 1 (screw 2) according to the rule above without turning it to the side.

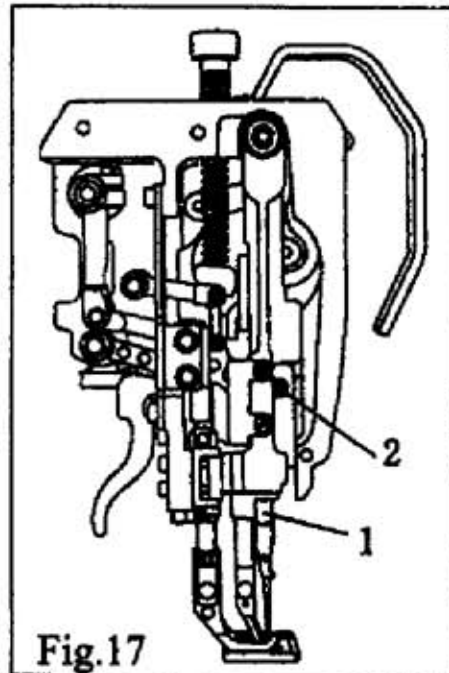
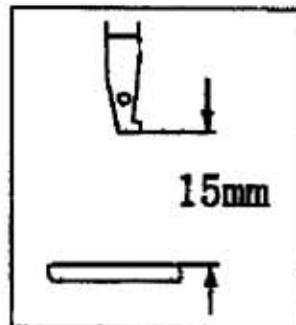

4) Presser Foot, Walking Foot and Feed Dog Sliding Movement (Fig.18)

When adjusting the maximum stitch-length and when the needle bar is in lower position, walking foot, presser foot and feed dog should make no movement when operating the lever.

① Adjust the maximum stitch length

② Loosen screw 1 only enough so that the feed lifting cam 2 turns round the shaft.

③ Bring the needle into lower position

④ While retaining this position, first push the eccentricity of the feed lifting cam 2 upwards, observing the above rule when operating the lever.

⑤ Tighten screws 1.

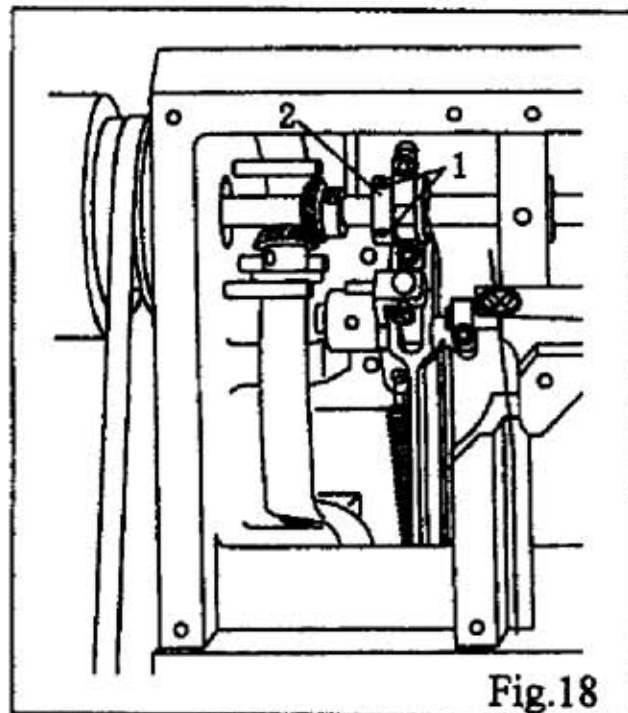

5) Hook Positioner, Grab distance and needle height(Fig.19)

When the stitch length is '0' and the position of the hook position is 1.8mm below the LD needle bar then;

① The grab point should stand at 'mid-needle' and the distance to the needle should be 0.05 – 0.1mm.

② The top edge of the eye of the needle should be 0.8mm below the grab point.

I) Adjust the stitch length to '0' and loosen screws 1 & 2 (screw 2 is on the back of the machine)

II) Bring the needle to lower position and push the 1.8mm thick measuring plate well under the lower needle bar bearing, bring the screw clip down to the measuring plate and screw tight.

III) Remove the measuring plate and turn the balance wheel until the screw clip lies at the needle bar.

IV) Push the grab onto the grab shaft according to rule ①

V) Turn the grab according to rule ② (adjust the needle height afterwards if necessary)

VI) Bring the grab shaft bearing 3 towards the grab and tighten screw 2.

VII) Tighten screw 1 making sure that the bevel wheel 4 is level with bearing 5.

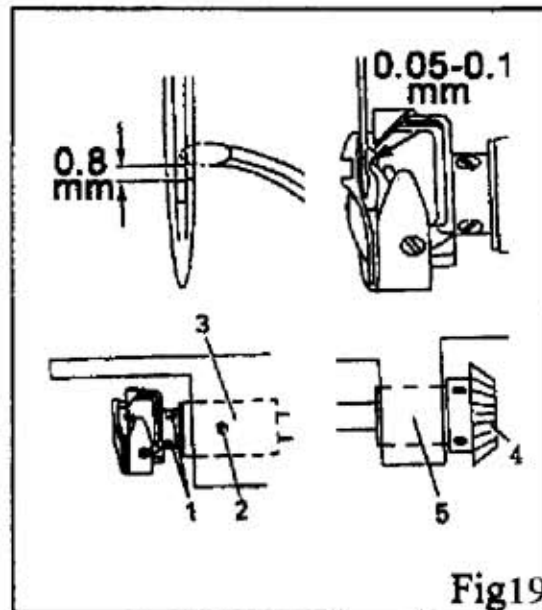

Fig19

6) Hydraulic movement of the walking foot and presser foot (Fig.20)

When the walking foot 3 is sitting on the needle plate the presser foot 6 and the needle point should reach the needle plate at the same time.

① Loosen nut 1.

② Push up bolts 2 and tighten nut 1.

③ Let the walking foot 3 rest on the needle plate.

④ Loosen screws 4 far enough that the lifting eccentric 5 turns around.

⑤ Turn lifting eccentric 5 according to the rule.

⑥ Tighten screws 4.

⑦ Do a test run.

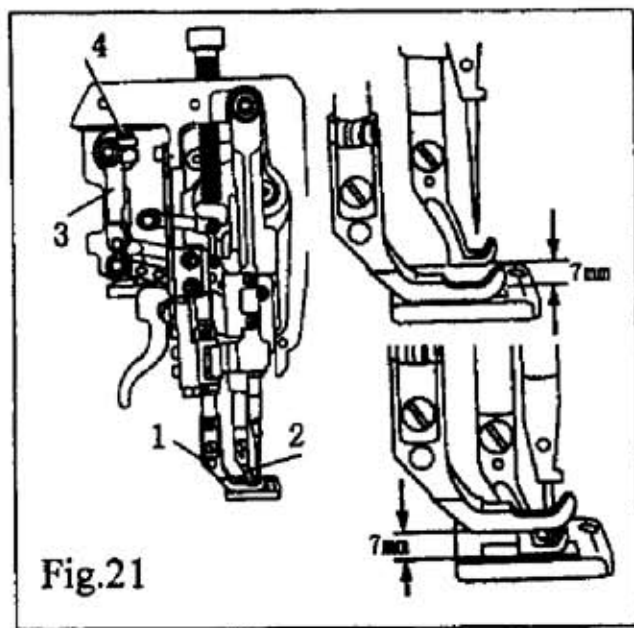
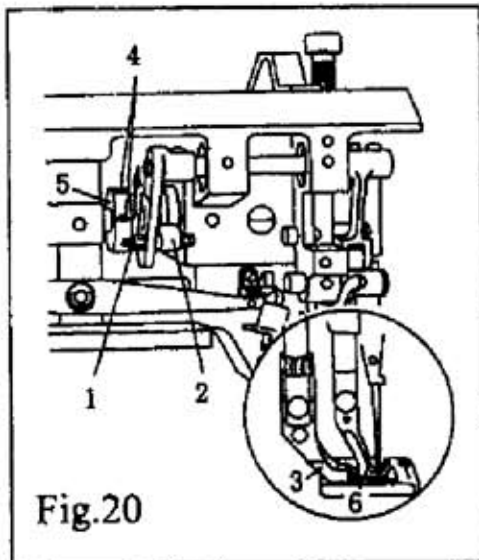

7) Presser Foot (Fig.21)

With the maximum presser foot adjustment and a stitch length of '0' the walking foot 1 and presser foot 2 should lift 7.0mm above the needle plate when turning the balance wheel.

- ① Adjust the walking foot to maximum and set the stitch length at '0'.
- ② Lower walking foot 1.
- ③ Turn the balance wheel until the presser foot 2 reaches it's highest point.
- ④ Turn crank 3 (screws 4) according to the above rule.

8) Upper thread tension regulation (Fig.22)

When the walking foot is high the two tension plates should be at least 0.5mm apart.

- ① Pull the walking foot up using the hand-lever.
- ② Position the pressure plate 1 behind the tension releasing plate 2 according to the above rule.

Note:

- ① The distance of 0.5mm is the minimum measurement and with thicker types of thread it can be over 1mm.
- ② Effective tension should not put a strain on the pin 3.

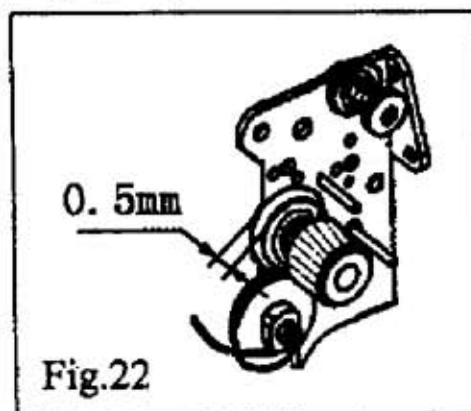

9) Thread Take-up Spring (Fig.23)

The thread take-up spring should stop moving when the needle point pierces the material (= about 7mm of spring movement)

The length of the thread take-up spring can deviate slightly up or down due to reasons of sewing technique.

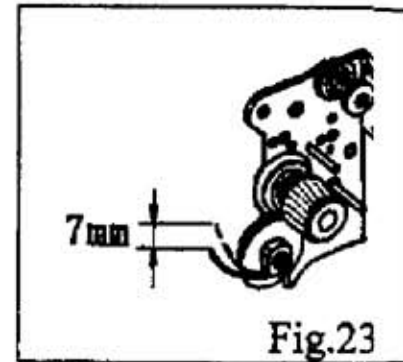

10) Bobbin Winder (Fig.24 Fig25)

① When the bobbin winder is activated the spindle should also be activated: when the bobbin winder is deactivated the rubbing wheel should not stand next to the drive wheel

② The bobbin winder should switch itself off when the filled quantity is still 1mm from the edge of the bobbin.

I) Push the drive wheel 1 (screws 2) according to rule 1.

II) Place a bobbin on the bobbiner, thread up the bobbin and switch on the bobbin winder.

III) Tighten bolts 3 (screws 4) according to rule 2.

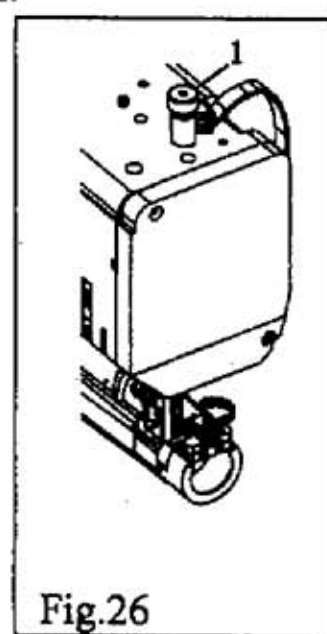
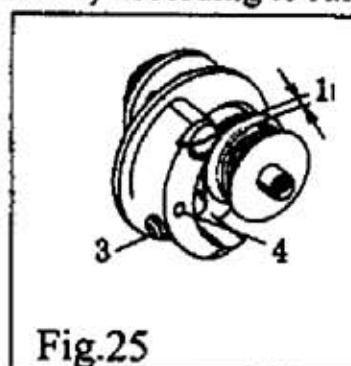
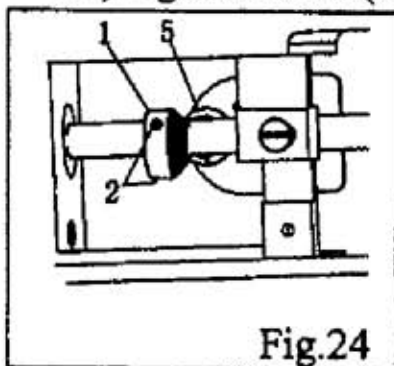

11) Adjustment of Presser Pressure (Fig.26)

The material should move smoothly even at top sewing speed. No pressure should show on the material.

Turn screw 1 according to the above rule.

A. ARM BED AND IT'S ACCESSORIES

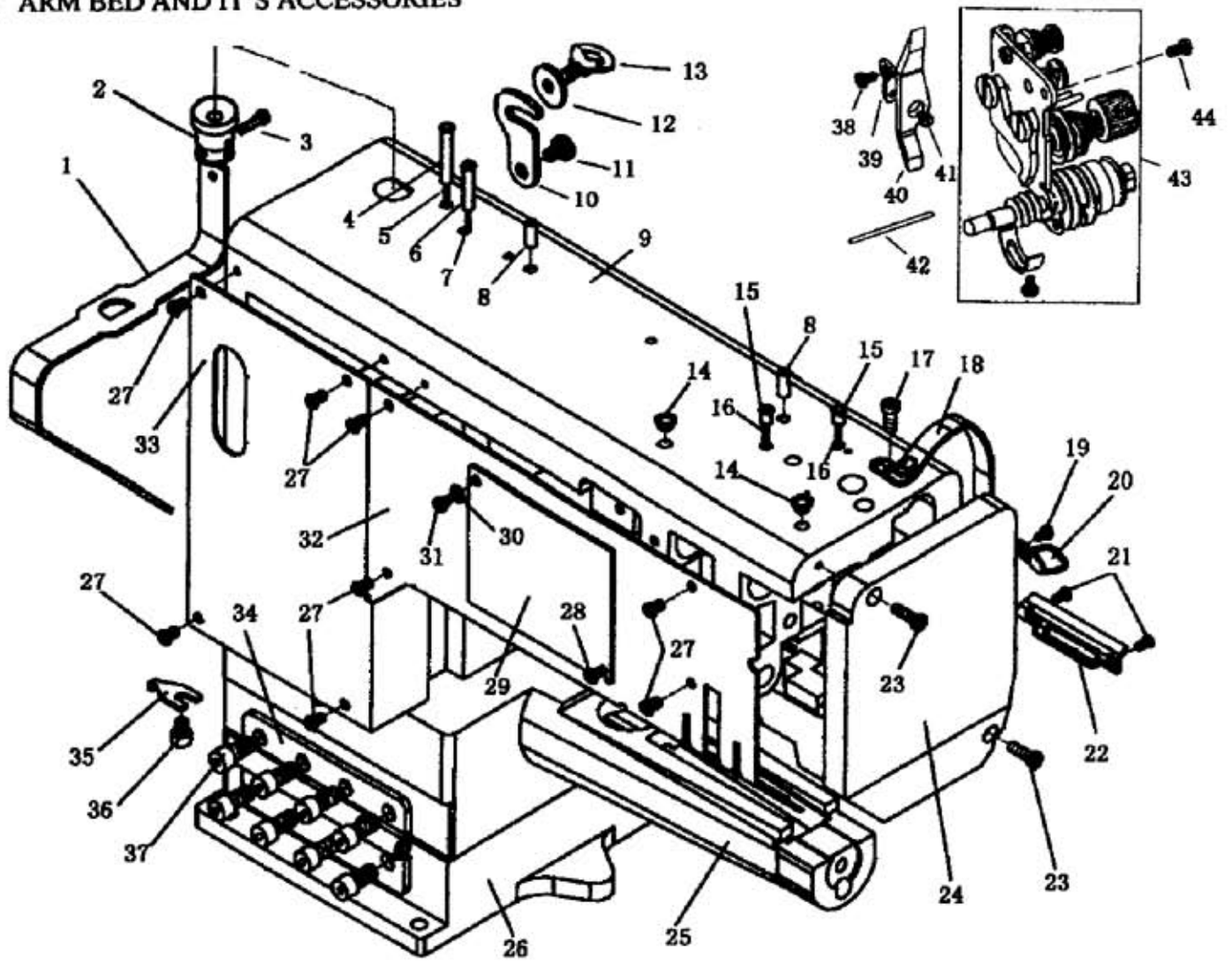

A. ARM BED AND IT'S ACCESSORIES

No.	Ref. No.	Description	Pcs.
A01	H7301001	Felt	1
A02	H7301002	Holder	1
A03	H7301003	Screw	1
A04	H7301004	Oil pipe	1
A05	H7301005	Oil wick	1
A06	H7301006	Oil pipe	1
A07	H7301007	Oil wick	1
A08	H7301008	Oil pipe	2
A09	H7301009	Arm	1
A10	H7301010	Link plate	1
A11	H7301011	Screw	1
A12	H7301012	Washer	1
A13	H7301013	Screw	1
A14	H7301014	Oil cup	2
A15	H7301015	Oil pipe	2
A16	H7301016	Oil wick	2
A17	H7301017	Screw	1
A18	H7301018	Thread take-up cover	1
A19	H7301019	Screw	1
A20	H7301020	Thread guide	1
A21	H7301021	Screw	2
A22	H7301022	Thread guide	1
A23	H7301023	Screw	2
A24	H7301024	Face plate	1
A25	H7301025	Arm bed	1
A26	H7301026	Supporter	1
A27	H7301027	Screw	8
A28	H7301028	Screw	1
A29	H7301029	Cover	1
A30	H7301030	Washer	1
A31	H7301031	Screw	1
A32	H7301032	Arm bed cover	1
A33	H7301033	Arm bed cover	1
A34	H7301034	Hinge	1
A35	H7301035	Holder	1
A36	H7301036	Screw	1

A. ARM BED AND IT' S ACCESSORIES

No.	Ref. No.	Description	Pcs.
A37	H7301037	Screw	8
A38	H7301038	Screw	1
A39	H7301039	Mounting plate	1
A40	H7301040	Lever	1
A41	H7301041	Screw	1
A42	H7301042	Thread releasing pin	1
A43	H7301043	Thread tension regulator complete	1
A44	H7301044	Screw	1

B. FEEDING AND FEED LIFTING, ROTATING HOOK SHAFT MECHANISM

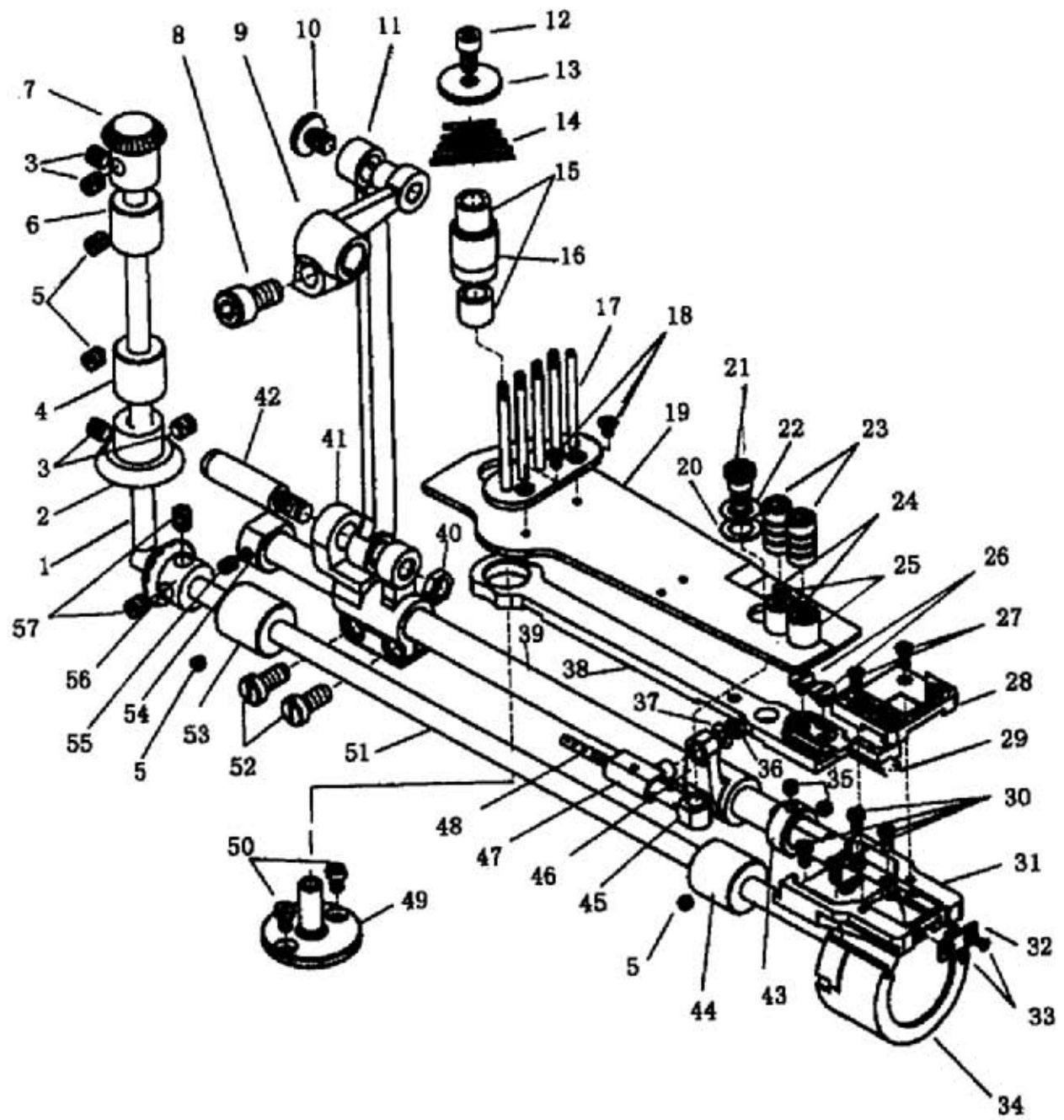

B. FEEDING AND FEED LIFTING, ROTATING HOOK SHAFT

No.	Ref. No.	Description	Pcs.
B01	H7302001	Vertical shaft	1
B02	H7302002	Vertical shaft gear (lower)	1
B03	H7302003	Set screw	4
B04	H7302004	Vertical shaft bushing (lower)	1
B05	H7302005	Set screw	4
B06	H7302006	Vertical shaft bushing (upper)	1
B07	H7302007	Vertical shaft gear (upper)	1
B08	H7302008	Screw	1
B09	H7302009	Crank	1
B10	H7302010	Screw	1
B11	H7302011	Connecting rod for feed lifting	1
B12	H7302012	Screw	1
B13	H7302013	Washer	1
B14	H7302014	Spring for feed bar holder	1
B15	H7302015	Bearing for feed bar holder	2
B16	H7302016	Bushing for feed bar holder	1
B17	H7302017	Mounting plate complete	1
B18	H7302018	Screw	2
B19	H7302019	Wiggle plate	1
B20	H7302020	Washer	1
B21	H7302021	Pin	1
B22	H7302022	Washer	1
B23	H7302023	Nut	2
B24	H7302024	Screw	2
B25	H7302025	Bushing	2
B26	H7302026	Screw	2
B27	H7302027	Screw	2
B28	H7302028	Needle plate	1
B29	H7302029	Feed dog	1
B30	H7302030	Screw	4
B31	H7302031	Fixing plate bracket for the needle plate	1
B32	H7302032	Hook positioner	1
B33	H7302033	Screw	2
B34	H7302034	Cover	1
B35	H7302035	Set screw	2
B36	H7302036	Screw	1

B. FEEDING AND FEED LIFTING ROTATING HOOK SHAFT

No.	Ref. No.	Description	Pcs.
B37	H7302037	Washer	1
B38	H7302038	Feed bar	1
B39	H7302039	Feed rock shaft	1
B40	H7302040	Nut	1
B41	H7302041	Feed rock shaft crank (right)	1
B42	H7302042	Pin	1
B43	H7302043	Feed rock shaft collar (left)	1
B44	H7302044	Rotating hook shaft bushing (left)	1
B45	H7302045	Feed rock shaft crank (left) joint	1
B46	H7302046	Feed rock shaft crank (left)	1
B47	H7302047	Bracket	1
B48	H7302048	Oil wick	1
B49	H7302049	Feed bar holder	1
B50	H7302050	Screw	2
B51	H7302051	Rotating hook shaft	1
B52	H7302052	Screw	2
B53	H7302053	Rotating hook shaft bushing (right)	1
B54	H7302054	Feed rock shaft collar (right)	1
B55	H7302055	Set screw	1
B56	H7302056	Rotating hook shaft gear	1
B57	H7302057	Set screw	2

C. ARM SHAFT MECHANISM

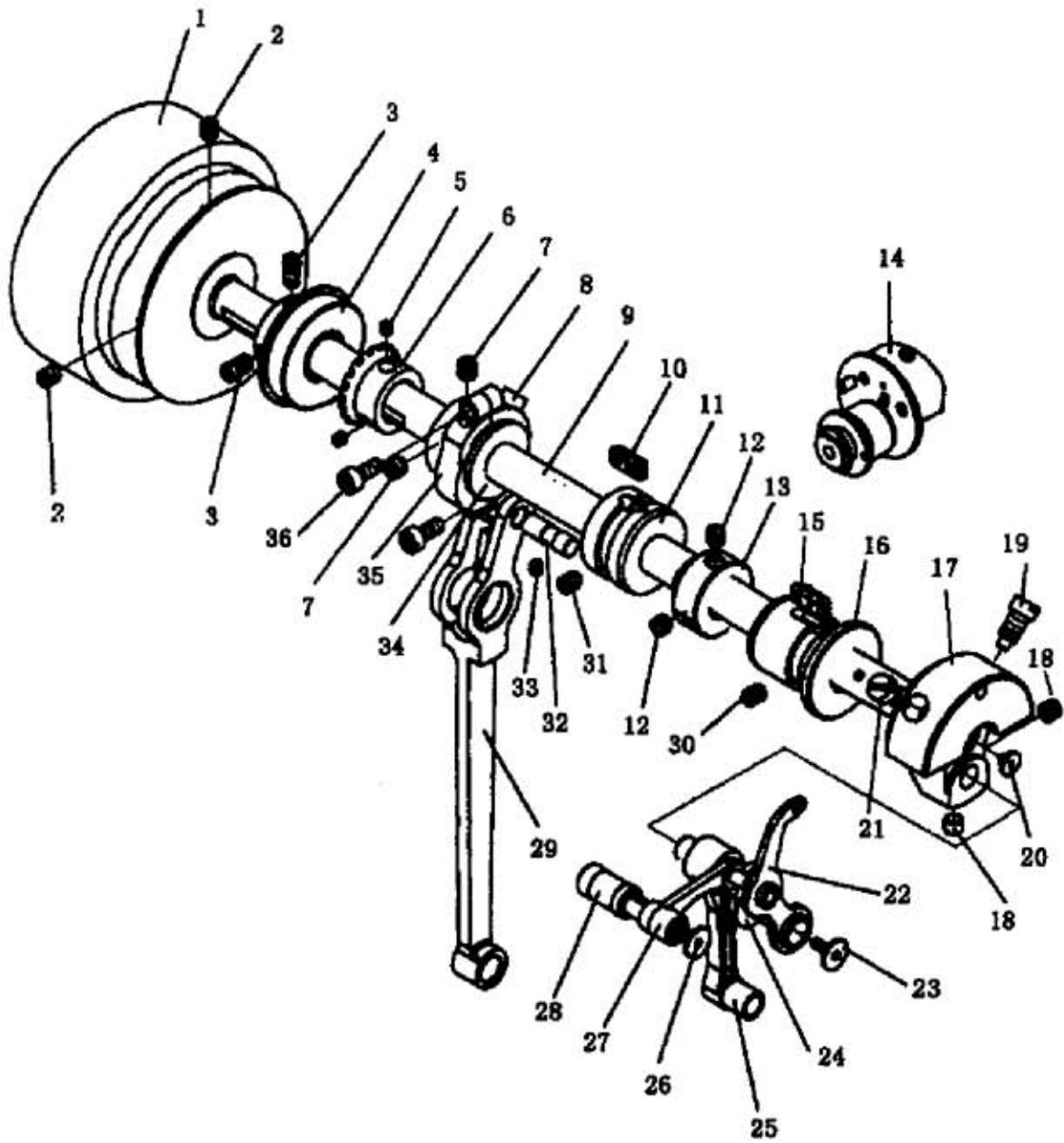

C. ARM SHAFT MECHANISM

No.	Ref. No.	Description	Pcs.
C01	H7303001	Balance wheel	1
C02	H7303002	Set screw	2
C03	H7303003	Set screw	2
C04	H7303004	Bearing	1
C05	H7303005	Screw	2
C06	H7303006	Bevel gear for arm shaft	1
C07	H7303007	Set screw	2
C08	H7303008	Bracket for feed cam crank	1
C09	H7303009	Arm shaft	1
C10	H7303010	Felt	1
C11	H7303011	Arm shaft bushing (middle)	1
C12	H7303012	Set screw	2
C13	H7303013	Wheel for bobbin winder	1
C14	H7303014	Bobbin winder assy	1
C15	H7303015	Felt	1
C16	H7303016	Arm shaft bushing (left)	1
C17	H7303017	Needle bar crank	1
C18	H7303018	Set screw	2
C19	H7303019	Screw	1
C20	H7303020	Arm shaft Plug	1
C21	H7303021	Screw	1
C22	H7303022	Thread take-up lever	1
C23	H7303023	Screw	1
C24	H7303024	Crank	1
C25	H7303025	Link for thread take-up	1
C26	H7303026	Screw	1
C27	H7303027	Link	1
C28	H7303028	Pin	1
C29	H7303029	Connecting rod for feed cam crank	1
C30	H7303030	Set screw	1
C31	H7303031	Set screw	1
C32	H7303032	Pin	1
C33	H7303033	Set screw	1
C34	H7303034	Feed cam	1
C35	H7303035	Cover for feed cam crank	1
C36	H7303036	Screw	2

D. STITCH REGULATOR MECHANISM

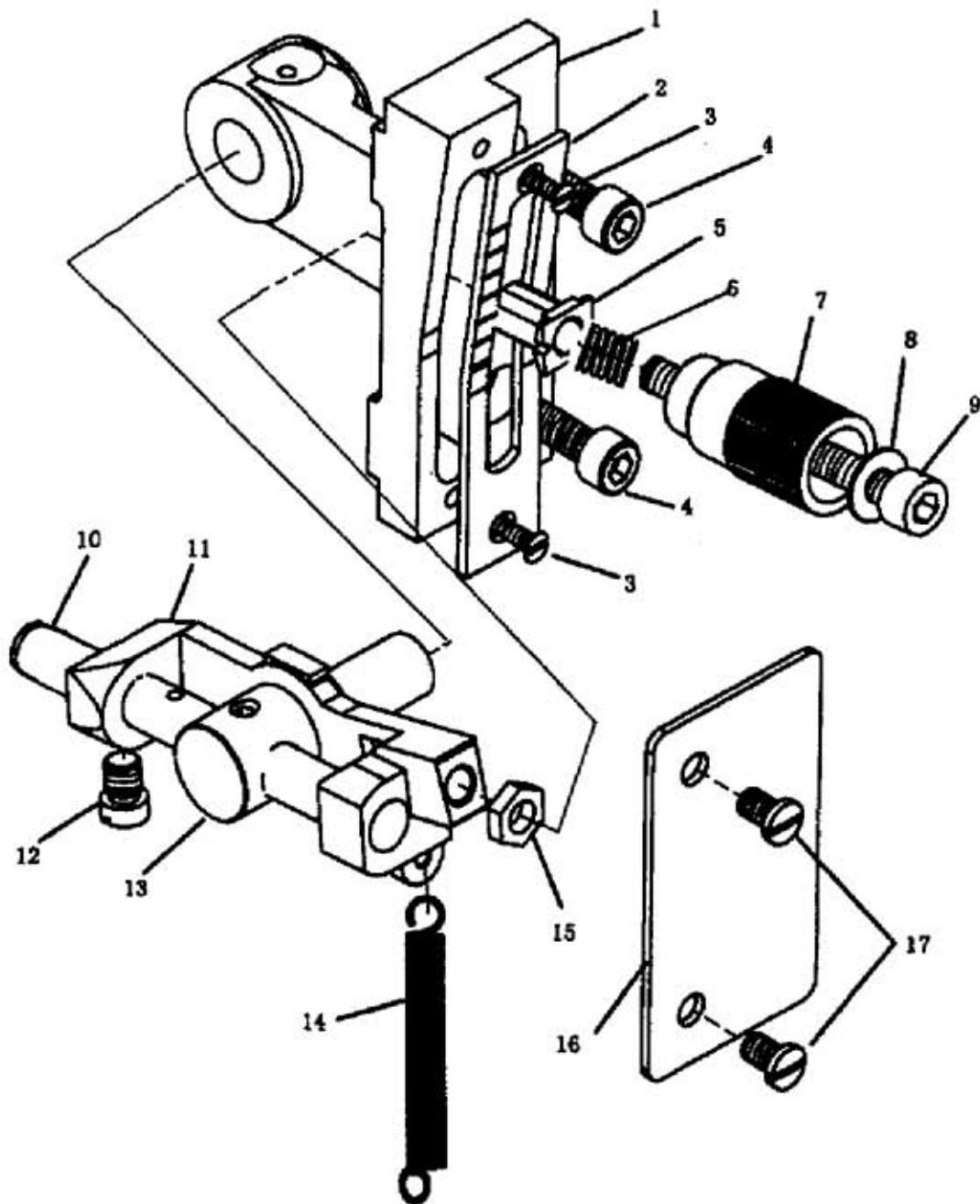

D. STITCH REGULATOR MECHANISM

No.	Ref. No.	Description	Pcs.
D01	H7304001	Bracket for stitch length plate	1
D02	H7304002	Stitch length plate	1
D03	H7304003	Screw	2
D04	H7304004	Screw	2
D05	H7304005	Guide bushing	1
D06	H7304006	Spring	1
D07	H7304007	Stitch length regulating nut assy	1
D08	H7304008	Washer	1
D09	H7304009	Stud	1
D10	H7304010	Pin	1
D11	H7304011	Setting frame	1
D12	H7304012	Screw	1
D13	H7304013	Guide bushing	1
D14	H7304014	Spring	1
D15	H7304015	Nut	1
D16	H7304016	Cover	1
D17	H7304017	Screw	2

E. PRESSER FOOT MECHANISM

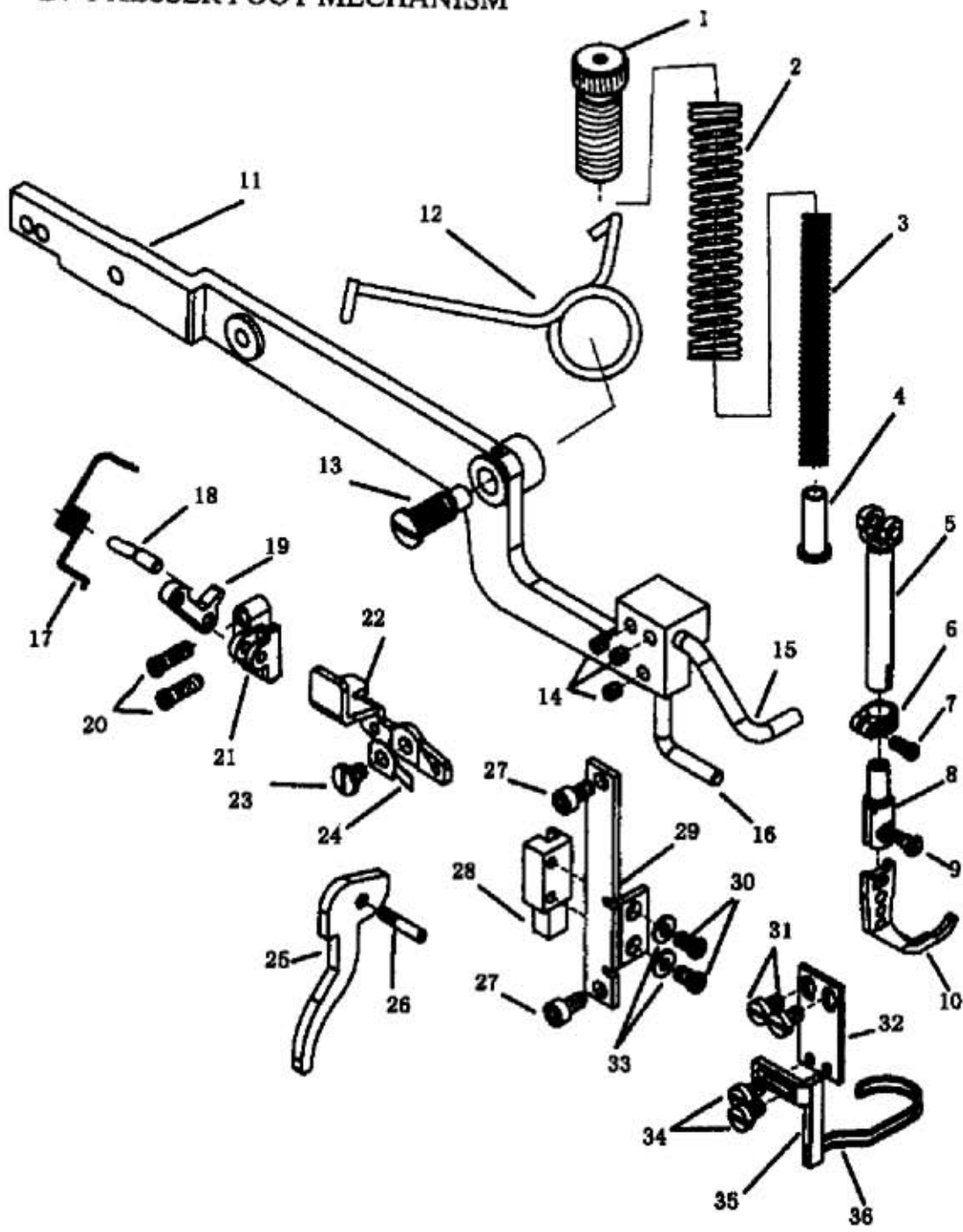

E. PRESSER FOOT MECHANISM

No.	Ref. No.	Description	Pcs.
E01	H7305001	Thumb screw	1
E02	H7305002	Spring	1
E03	H7305003	Spring	1
E04	H7305004	Pipe	1
E05	H7305005	Vibrating presser bar	1
E06	H7305006	Connecting stud for vibrating presser bar	1
E07	H7305007	Screw	1
E08	H7305008	Connecting stud for walking foot	1
E09	H7305009	Screw	1
E10	H7305010	Walking foot	1
E11	H7305011	Knee lifter lever	1
E12	H7305012	Spring	1
E13	H7305013	Screw	1
E14	H7305014	Set screw	3
E15	H7305015	Stop bar for knee lifter lever	1
E16	H7305016	Stop bar for knee lifter lever	1
E17	H7305017	Spring	1
E18	H7305018	Pin	1
E19	H7305019	Knee lifter lever crank	1
E20	H7305020	Screw	2
E21	H7305021	Bracket for knee lifter lever	1
E22	H7305022	Thread releasing disc	1
E23	H7305023	Screw	1
E24	H7305024	Spring	1
E25	H7305025	Presser bar lifter	1
E26	H7305026	Screw	1
E27	H7305027	Screw	2
E28	H7305028	Walking foot guide plate	1
E29	H7305029	Mounting frame	1
E30	H7305030	Screw	2
E31	H7305031	Screw	2
E32	H7305032	Walking foot guard cover plate	1
E33	H7305033	Washer	2
E34	H7305034	Screw	2
E35	H7305035	Walking foot guard cover bracket	1
E36	H7305036	Walking foot guard cover	1

F. NEEDLE BAR FEEDING MECHANISM

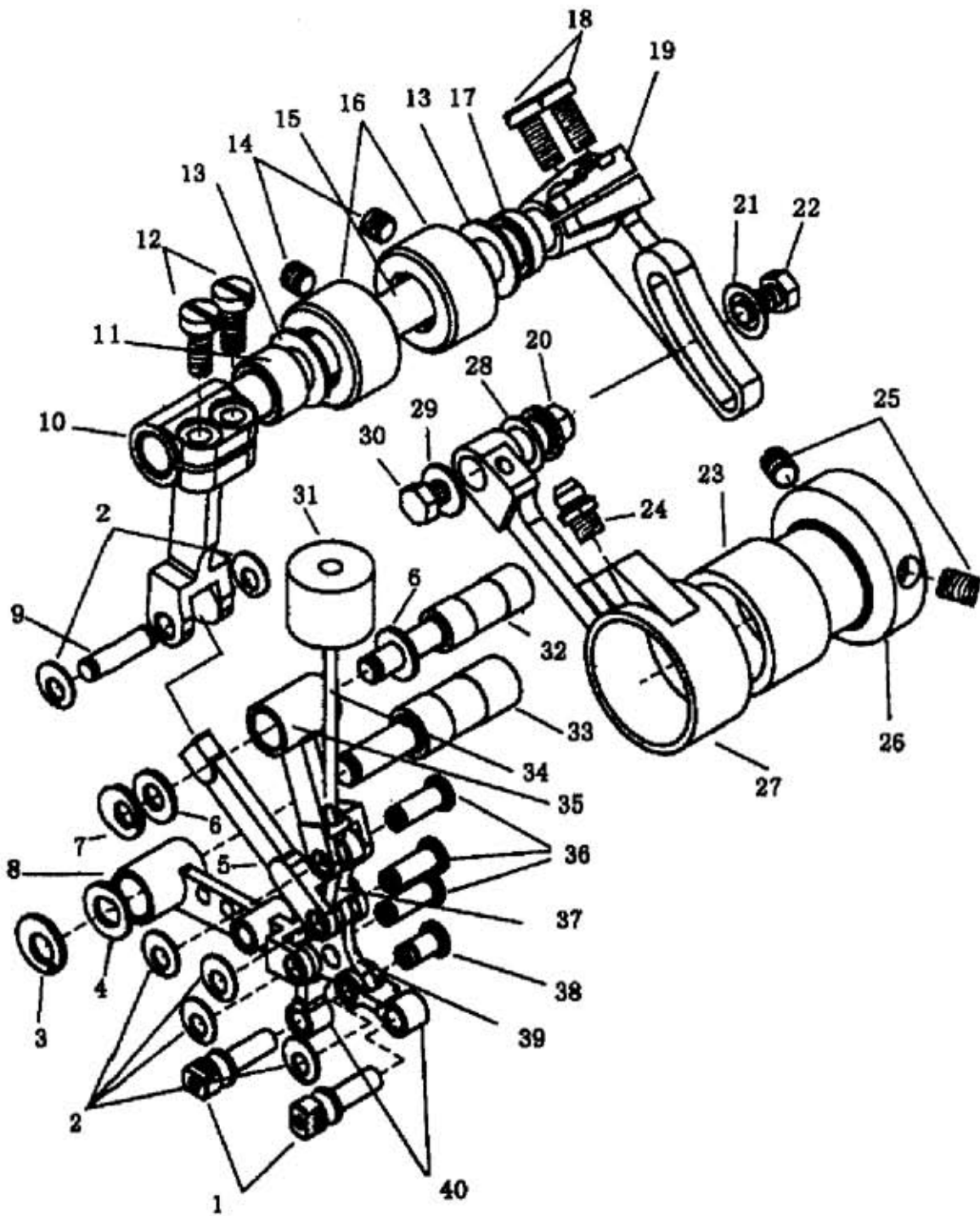

F. NEEDLE BAR FEEDING MECHANISM

No.	Ref. No.	Description	Pcs.
F01	H7306001	Slide block	2
F02	H7306002	Stop ring	6
F03	H7306003	Stop ring	1
F04	H7306004	Washer	1
F05	H7306005	Connecting rod	1
F06	H7306006	Washer	2
F07	H7306007	Stop ring	1
F08	H7306008	Connecting rod complete	1
F09	H7306009	Pin	1
F10	H7306010	Connecting rod	1
F11	H7306011	Bushing (left)	1
F12	H7306012	Screw	2
F13	H7306013	Washer (left)	2
F14	H7306014	Screw	2
F15	H7306015	Upper feed lifting rock shaft	1
F16	H7306016	Bushing for upper feed lifting rock shaft	2
F17	H7306017	Bushing (right)	1
F18	H7306018	Screw	2
F19	H7306019	Regulating crank	1
F20	H7306020	Pin	1
F21	H7306021	Washer	1
F22	H7306022	Screw	1
F23	H7306023	Bearing	1
F24	H7306024	Oil cup	1
F25	H7306025	Screw	2
F26	H7306026	Cam for presser foot lifting	1
F27	H7306027	Connecting rod	1
F28	H7306028	Washer	1
F29	H7306029	Washer	1
F30	H7306030	Screw	1
F31	H7306031	Felt	1.
F32	H7306032	Pin	1
F33	H7306033	Pin	1
F34	H7306034	Spring guide bar	1
F35	H7306035	Connecting rod	1
F36	H7306036	Pin	3

F. NEEDLE BAR FEEDING MECHANISM

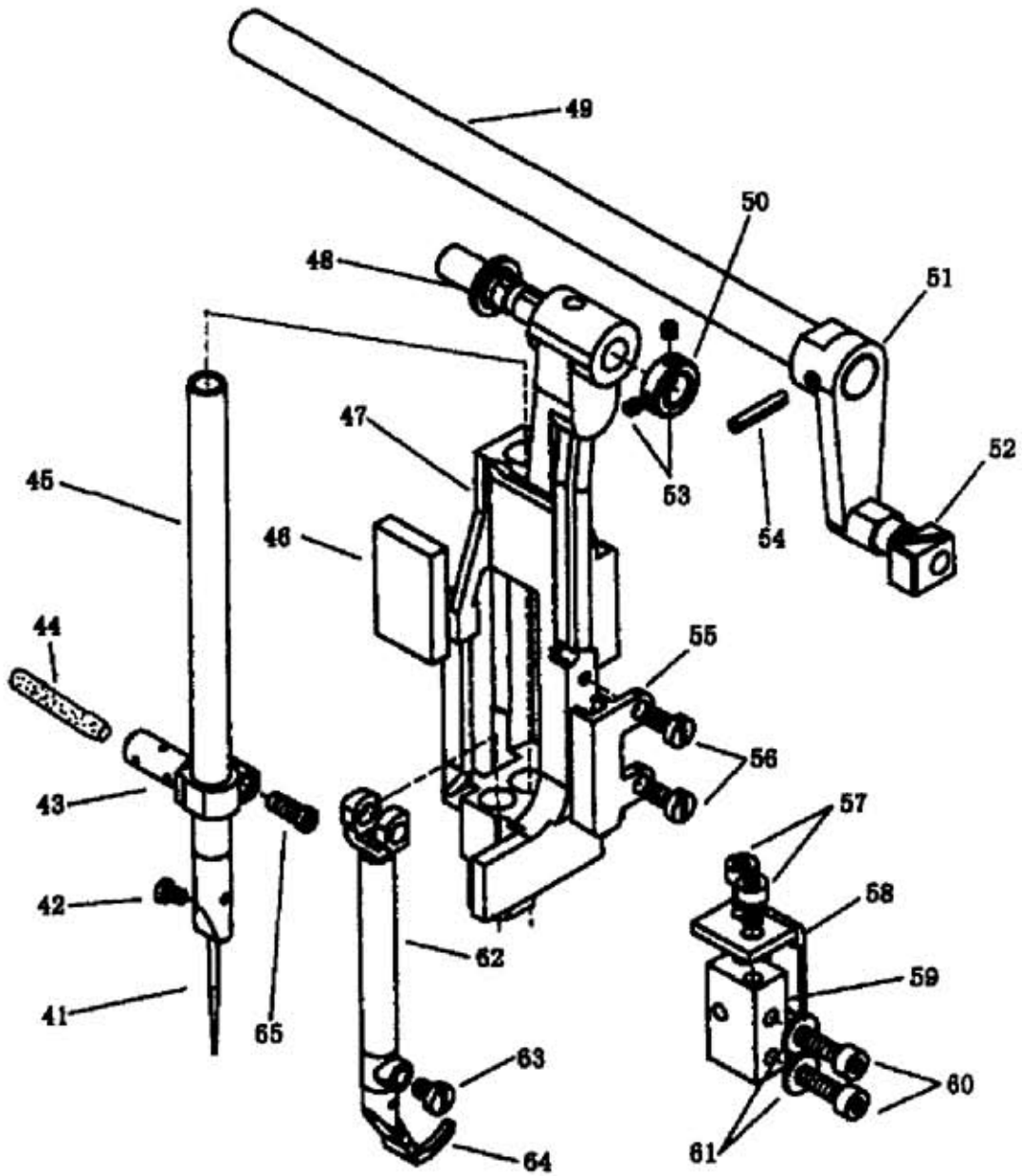

F. NEEDLE BAR FEEDING MECHANISM

No.	Ref. No.	Description	Pcs.
F37	H7306037	Connecting rod	1
F38	H7306038	Pin	1
F39	H7306039	Crank	1
F40	H7306040	Connecting rod	2
F41	H7306041	Needle	1
F42	H7306042	Screw	2
F43	H7306043	Needle bar connecting stud	1
F44	H7306044	Oil wick	1
F45	H7306045	Needle bar	1
F46	H7306046	Felt	1
F47	H7306047	Needle bar rock frame	1
F48	H7306048	Pin	1
F49	H7306049	Needle bar rock shaft	1
F50	H7306050	Collar	1
F51	H7306051	Needle bar rock shaft crank	1
F52	H7306052	Square block	1
F53	H7306053	Screw	2
F54	H7306054	Pin	1
F55	H7306055	Guide plate for slide block	1
F56	H7306056	Screw	2
F57	H7306057	Screw	2
F58	H7306058	Fixing plate	1
F59	H7306059	Guide plate for needle bar rock frame	1
F60	H7306060	Screw	2
F61	H7306061	Washer	2
F62	H7306062	Presser bar	1
F63	H7306063	Screw	1
F64	H7306064	Presser foot	1
F65	H7306065	Screw	1

G. ACCESSORIES

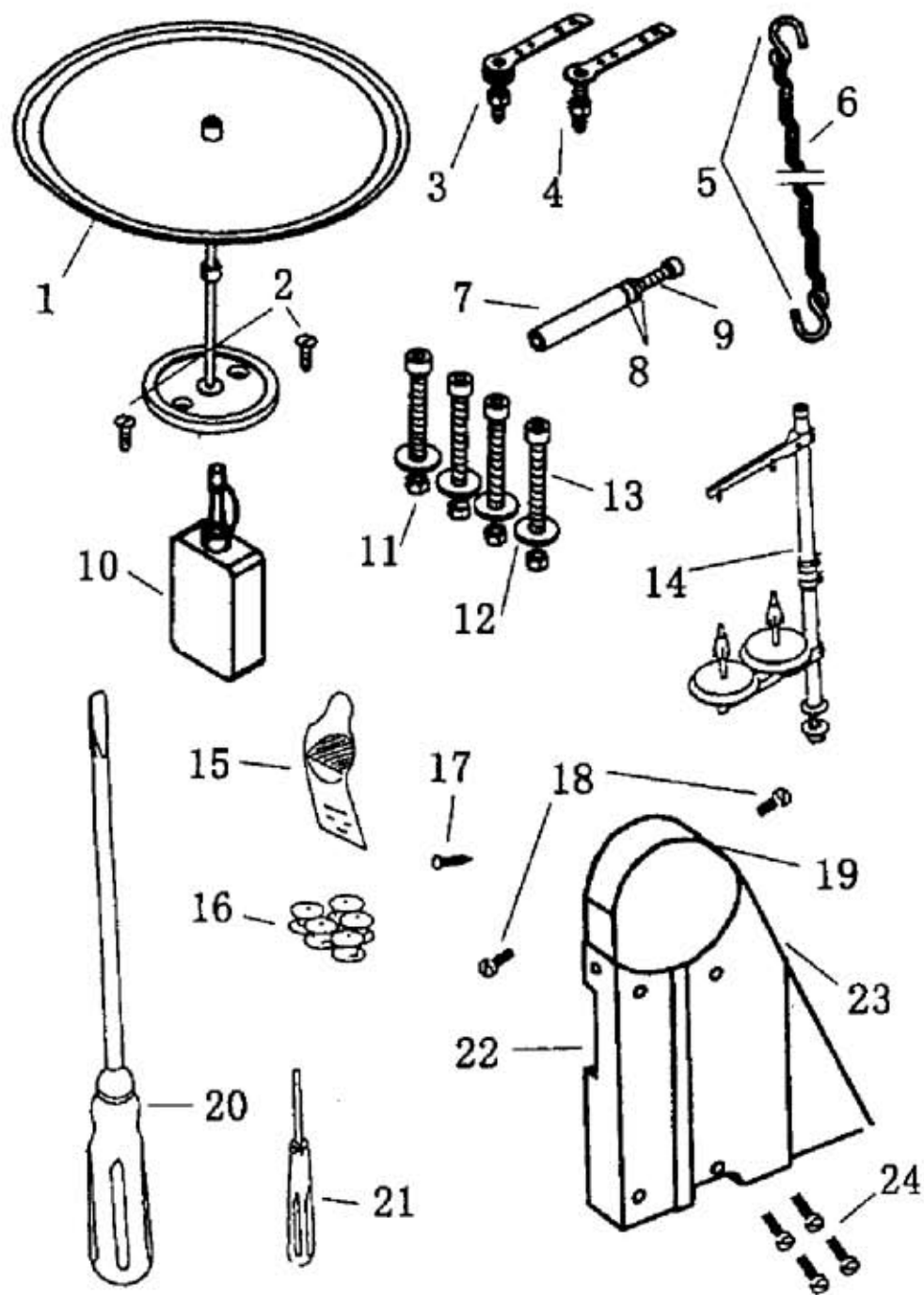

G. ACCESSORIES

No.	Ref. No.	Description	Pcs.
G01	H7307001	Plate complete	1
G02	H7307002	Screw	2
G03	H7307003	Bobbin winder assy	1
G04	H7307004	Thread guide	1
G05	H7307005	Pothook	2
G06	H7307006	Chain	1
G07	H7307007	Bushing	1
G08	H7307008	Stop ring	2
G09	H7307009	Screw	1
G10	H7307010	Oil tank	1
G11	H7307011	Nut	4
G12	H7307012	Washer	4
G13	H7307013	Screw	4
G14	H7307014	Thread stand assy	1
G15	H7307015	Needle	
G16	H7307016	Bobbin	5
G17	H7307017	Wood screw	5
G18	H7307018	Screw	2
G19	H7307019	Belt cover (upper)	1
G20	H7307020	Screw driver (large)	1
G21	H7307021	Screw driver (small)	1
G22	H7307022	Belt cover (left)	1
G23	H7307023	Belt cover (right)	1
G24	H7307024	Screw	4