

ARTISAN®



ARTISAN®

20-53

**Operators Manual
and
Spare Parts Booklet**

CONTENTS

1. Application.....	1
2. Secure operation.....	1
3. Caution before operation.....	1
4. Lubrication.....	1
5. The selection of thread.....	2
6. The Inserting of needle.....	2
7. Dismounting the bobbin case.....	2
8. Wind the bobbin case (20U33/43/53/53A/63/143, 457A/B/D).....	3
9. Thread the bobbin case (20U23/23D).....	3
10. Assemblage of the bobbin.....	3
11. Mounting of bobbin case.....	4
12. Thread the surface stitch.....	4
13. Adjustment of the thread length.....	5
14. Adjustment of pressure of presser foot.....	5
15. Adjustment of surface thread tension.....	6
16. Regulating the take-up spring.....	6
17. Adjustment of bobbin thread tension.....	6
18. Needle position selection (20U33/43/53/53A/63).....	6
19. Horizontal needle width regulate.....	7
20. Locking unit for linear stitching.....	7
21. Assemblage of belt cover.....	7
22. Mount Knee lifter (20U23/23D/33/43/143/, 457A/B/D).....	8
23. Mount Knee lifter (20U53/53A/63).....	8
24. Mode of sewing and application of accessories.....	9
25. Main specification.....	11
26. The maintain of machine.....	11

1. APPLICATION

- Zigzag embroidery stitch
- Perfect lockstitch
- Extra accurate control stitch to assure the perfect embroidery stitch
- This kind of zigzag sewing machine is applicable to thin/medium/heavy material

2. SECURE OPERATION

1. The operator should be trained and understand the operation manual.
2. While using it, the secure equipment is expected to do well.
3. Turn off the power or draw the power off, while unfix some of the accessories, winding thread and no operator is on the workplace of maintain the machine.
4. The maintain and adjustment of the machine must be do by the professional technique.
5. While maintain the pneumatic system, the power system should be shut off and be checked by professional technique.
6. The power equipment should be in charge of by professional technique.
7. Do maintain the machine, as per the security adjustment method to operate.

Meanings of the symbols:



Danger spot!
Items requiring special attention



Danger of injury to operative or service staff.
Besure to observe and adhere to these safety notes!



Earth

3. CAUTION BEFORE OPERATION



To avoid the damage of the machine, do care of the following:

1. The first time for the machine work, it should be added enough oil to wash it completely.
2. Check the power of the motor whether it do normally or the connection box is connect well.
3. The upper wheel should rotate in the operator direction.

4. LUBRICATION (Fig 1,2)

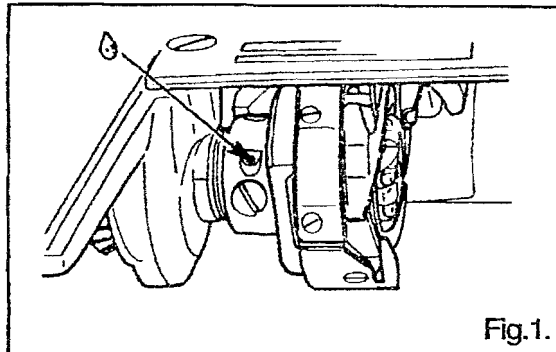

Fig.1.

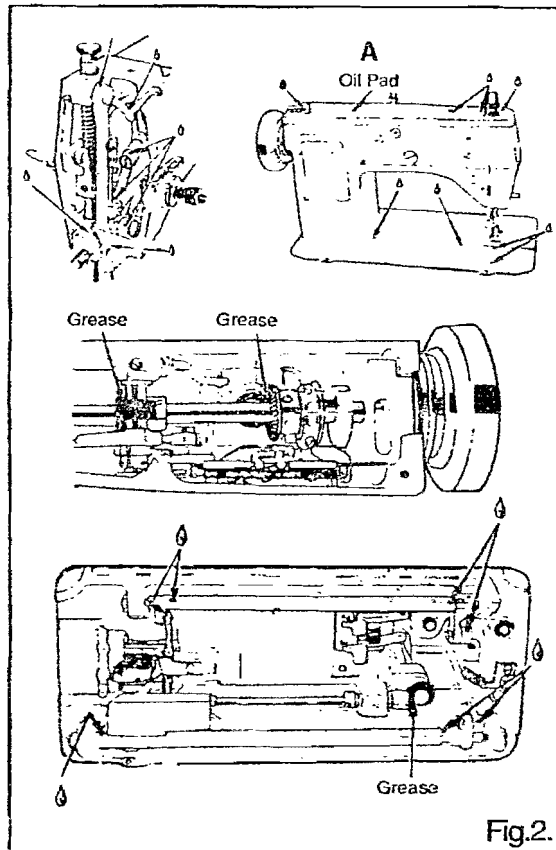



Fig.2.

	 CAUTION
	<p>Switch off the machine</p> <p>Set sewing head upring again using both hands.</p> <p>Danger of crushing between sewing head and table top.</p>

1. Rotate the upper wheel to the oil hole "G", add 1-2 drip of oil.
2. The sign "G" is expected to add 1-2 drip of oil,
3. Add the little oil to the sign "B" (on the gear)
4. Pls add enough oil to the sign "A" in the head.
5. Lubrication oil is advised to use NO:2 sewing machine white oil or NO.HT-7 technique oil.



5. THE SELECTION OF THE THREAD

Select the thread according to the sewing material and refer to the following.

Application model	Thin material	Medium/heavy material	Heavy material
Teh max of thread size	120	60	30
Needle-size (l/100mm)	10	12-16 (80-100)	18-19 (110-120)
The model of needle	1910-05(135*9)		
Other equivalent size of thread is applicable			

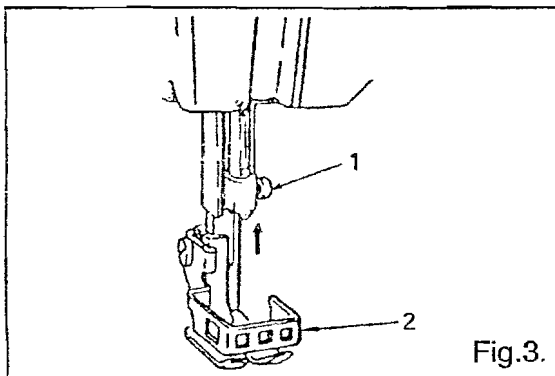
6. THE INSERTING OF NEEDLE(Fig3)





	 CAUTION
	<p>Switch off the machine</p> <p>Do not operate without finger guard (2). (See Fig.3)</p> <p>Danger of injury</p>

Turning the hand wheel and raise the needle bar to the highest position, then loose the needle tighten screw 1.insert the needle in the needle bar and push it up as far as it will go.

Make sure its long groove faces toward the front. Tighten needle set screw 1 securely.

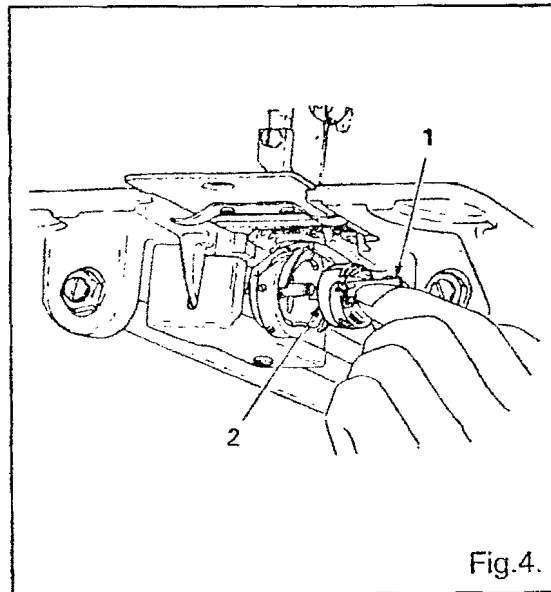
7. DISMOUNTING THE BOBBIN CASE (Fig 4)



	 CAUTION
	<p>Switch off the machine</p> <p>Do not operate machine with throat plate left open.</p>

1. Raise latch 1
2. Pick out the bobbin case 2

8. WIND THE BOBBIN (Fig 5,6)

(20U33/43/53/63/143, 457A/B/D)

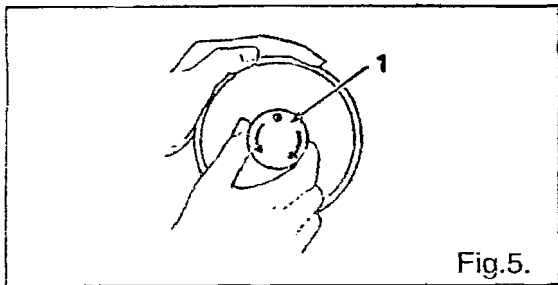

Fig.5.

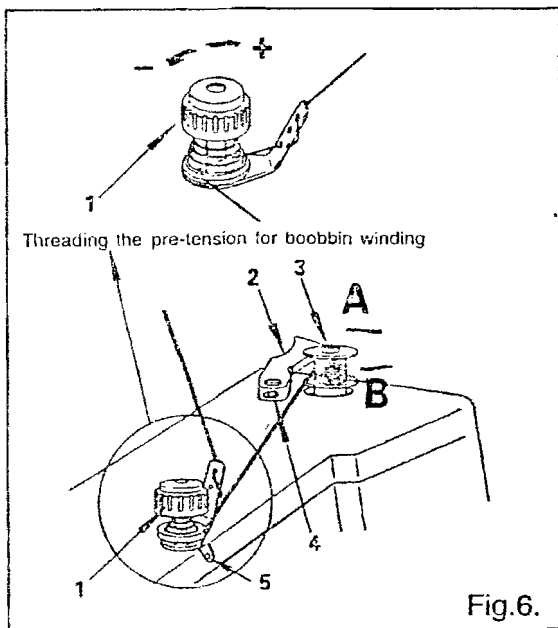
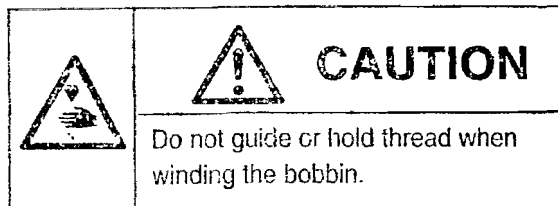

Fig.6.



1. Stop motion needle by loosening stop-motion screw 1, hold hand wheel with left hand and turn stop-motion screw toward you with right hand.
2. Place bobbin on bobbin winder spindle 3, pushing it on as far as it will go. pre-tension 1.
 - +-----more tension
 - less tension

3. Push latch (2) in the direction indicated by arrow (A), bobbin winder spindle (3) rotates in the direction indicated by arrow (B), to adjust the amount of thread on bobbin, loosen screw (4) on latch (2) and swing the latch away from you or toward you, as required.

4. If the thread is uneven on bobbin, firstly loose the screw 5, move the pre-tension up or down, as required and tighten screw 5.

9. THREAD THE BOBBIN CASE (Fig. 7)

(20U23/23D)

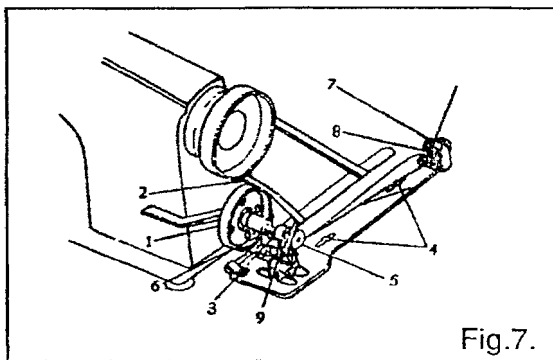
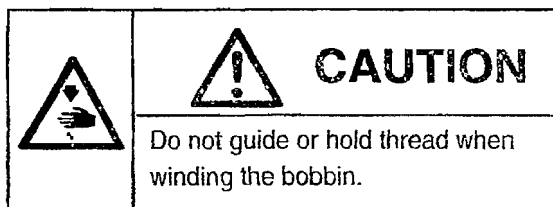

Fig.7.



1. Put the shuttle core into the winding shaft, push the thread adjustment plate 9, wind the shuttle thread.

2. Adjust the screw 8, to change the tension of the winding thread.

10. ASSEMBLAGE OF THE BOBBIN (Fig 8.9.10.11)

1. Put the bobbin into bobbin case. Pull thread into notch 1 and draw it under tension spring 2. (Fig.9)

2. Draw thread out from slot 2 on end of spring 1. (Fig.10) and pass it through bobbin case thread guide (1), allow about 60mm of thread out of the bobbin. (Fig.11)

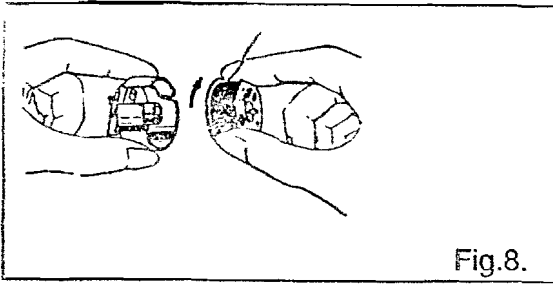

Fig.8.

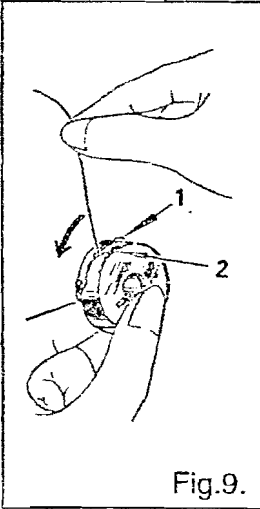

Fig.9.

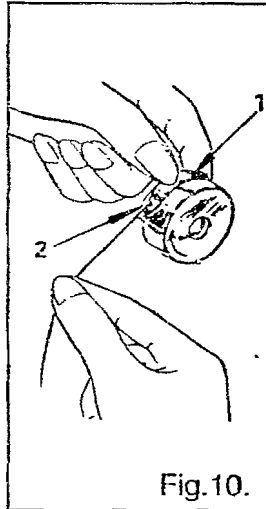

Fig.10.

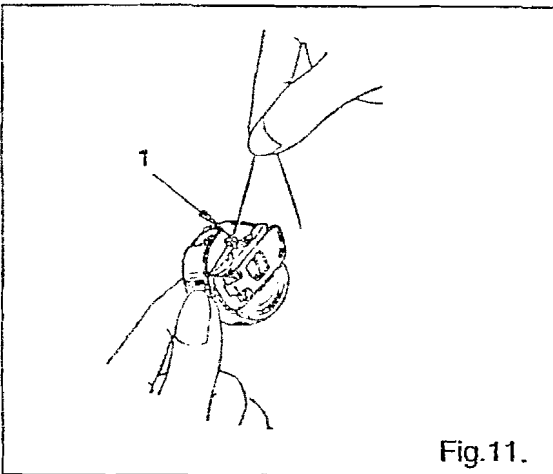

Fig.11.

11.MOUNTING OF THE BOBBIN CASE(Fig. 12)

1.Open bed slide and lay the case on the case shaft 2, while the case hook fit location channel, then down the bed slide and press the case and push the plate.

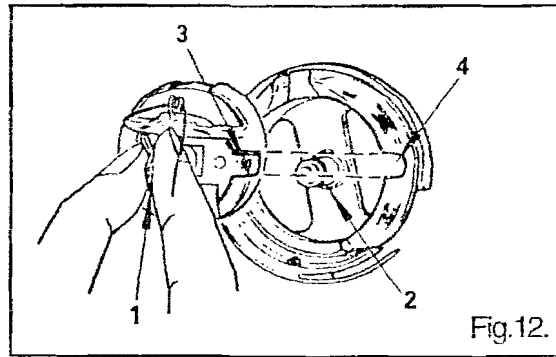

Fig.12.

	<p>CAUTION</p> <p>Switch off the machine. Do not run machine without closing bed slide. Dandger of injury!</p>
--	---

12. THREAD SURFACE STITC - HES(Fig.13,14,15,16)

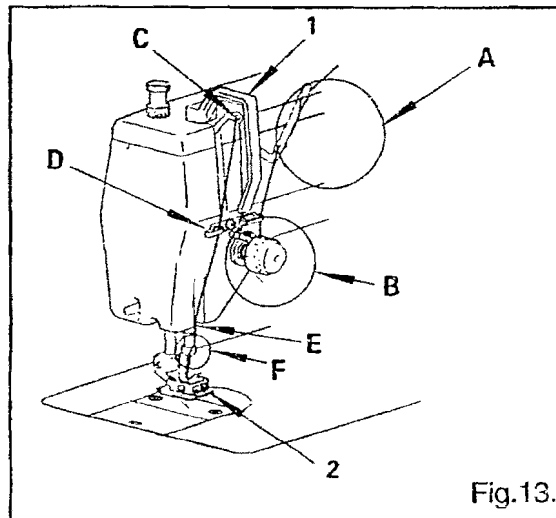

Fig.13.

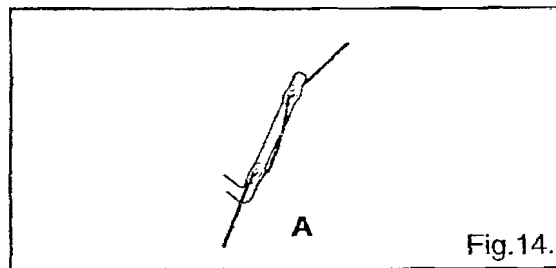
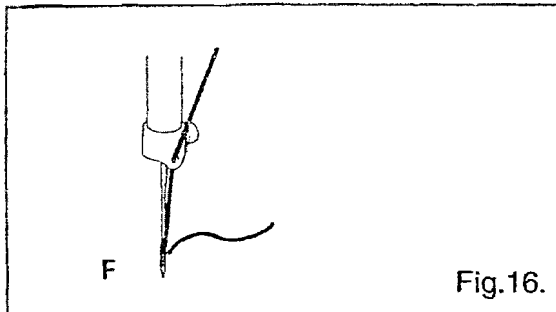
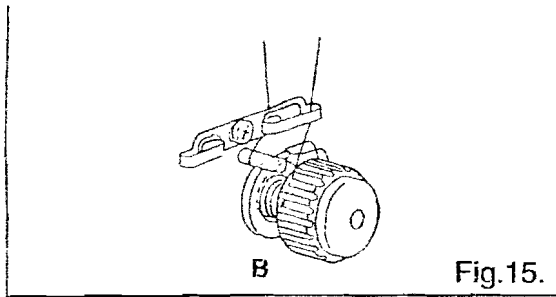

Fig.14.



		<h2>CAUTION</h2>
<p>Switch off the machine. Do not operate without thread take-up guard. Do not operate without finger guard Danger of injury!</p>		

1. Raise the needle bar to the highest position, then pull the thread out and through A(Fig. 13), B(Fig. 14), C,D,E and F.(Fig. 16)
2. As fig. 16, thread from forward to back.
3. Pull about 100mm of thread out.

13. ADJUST STITCH LENGTH, (Fig. 17)

Regulating the stitch length:

1. To regulate the stitch length, turn feed regulating dial 1 toward left or right as required.

+-----to lengthen
 -----to shorten

2. Changing the reverse feed:

Push lever 2, Fig 17, down for reverse feed and release for forward feed.

The following is applicable to 20U53/63/53A.

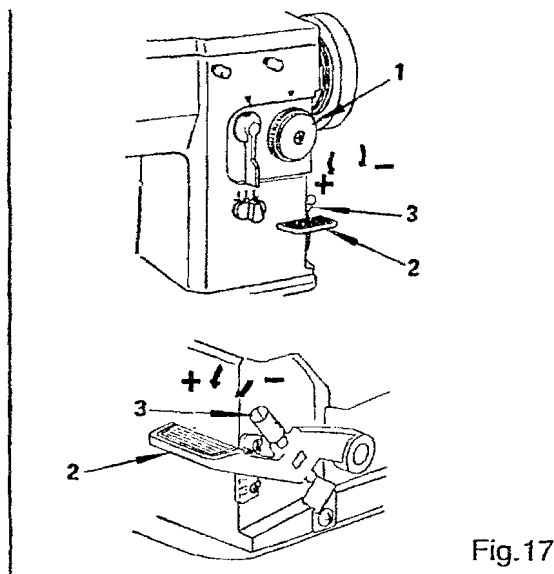

To regulate the reverse stitch length, turn thumb screw 3 toward left or right as required.

+-----length
 -----shorten

14. ADJUST PRESSER FOOT PRESSURE (Fig. 18)

To regulate the presser foot pressure, turn thumb screw 1, toward left or right as required, (Fig. 18)

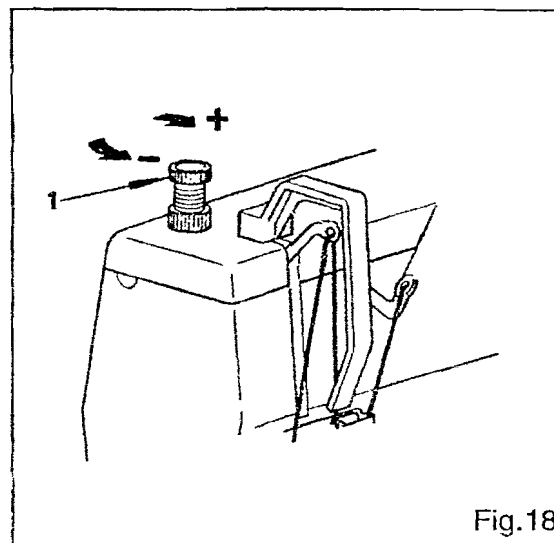

15. ADJUST NEEDLE THREAD TENSION (Fig.19)

Regulate needle thread tension with tension regulating knob 1. Fig.19.

- +-----more tension
- less tension

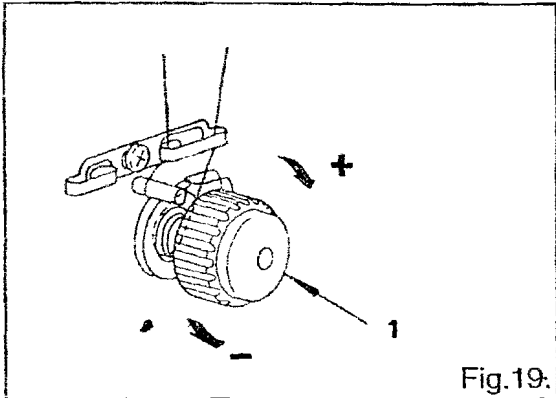

Fig.19.

16. REGULATE THE TAKE-UP SPRING (Fig.20)

Using a screwdriver in slot of stud 1, Fig.20 regulate take-up spring tension by turning stud (1) as required.

- +-----more tension.
- less tension.

To adjust the amount of take-up spring movement, loosen screw 2 and set take-up spring height by turning the entire tension assembly 3 toward left or right. Securely tighten screw 2.

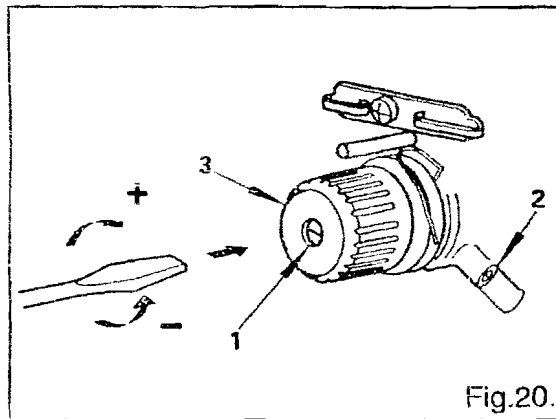

Fig.20.

17. ADJUST BOBBIN THREAD TENSION (Fig.21)

Regulate bobbin thread tension regulating screw 1. Fig.21.

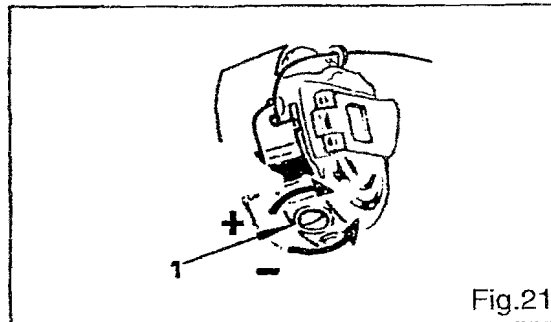

Fig.21.

18. THE SELECTION OF NEEDLE PLATE (Fig.22)

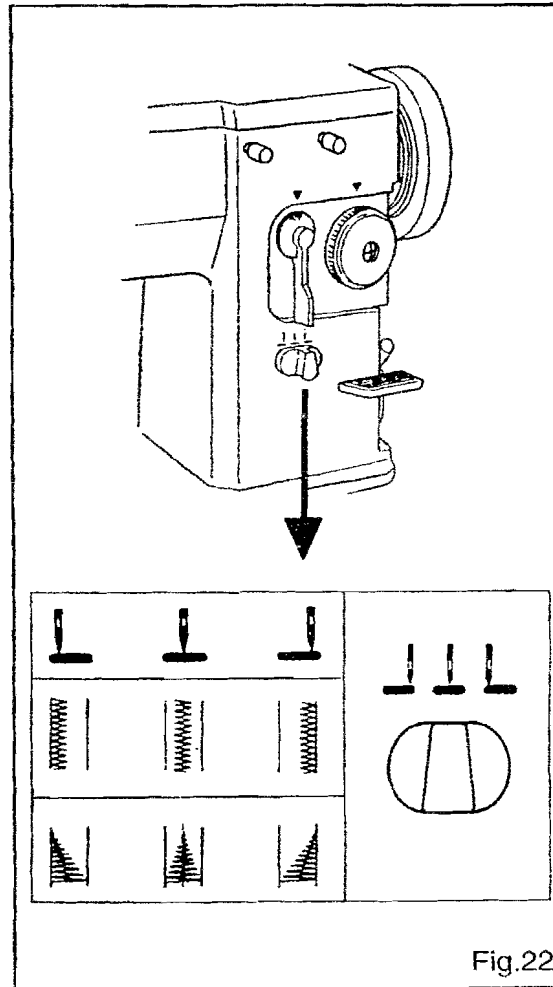
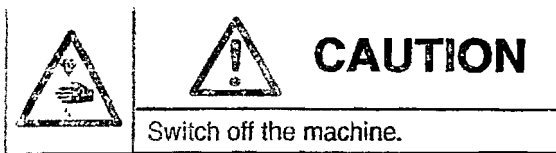

Fig.22.



(20U33/43/53/53A/63)

Left, right, middle needle is applicable to lockstitch and zigzag machine.

You can sew the equivalent stitch if you move the single side zigzag knob to expectable position.

You are forbid to adjust the needle position while the material is under the stitch.

19. THE ADJUSTMENT OF HORIZONTAL DISTANCE (Fig.23)

If one fixed value between the min-max of curvilinear stitch is needed, the adjustment can be made as follows:

Release the horizontal needle set screw 2, turn the spanner 3 to A position, then lock the set screw 2, release the needle set screw 1; turn the spanner 3 to B position, then lock the set screw 1.

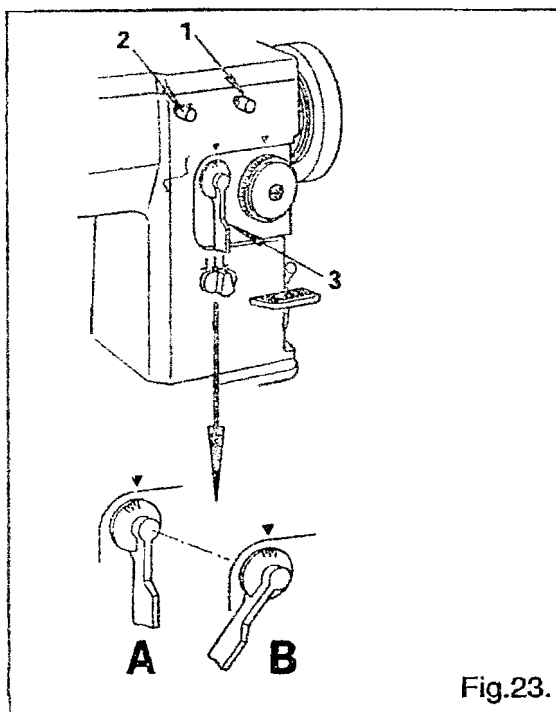

Fig.23.

20. LOCKING UNIT FOR LINEAR STITCHING (Fig.24)

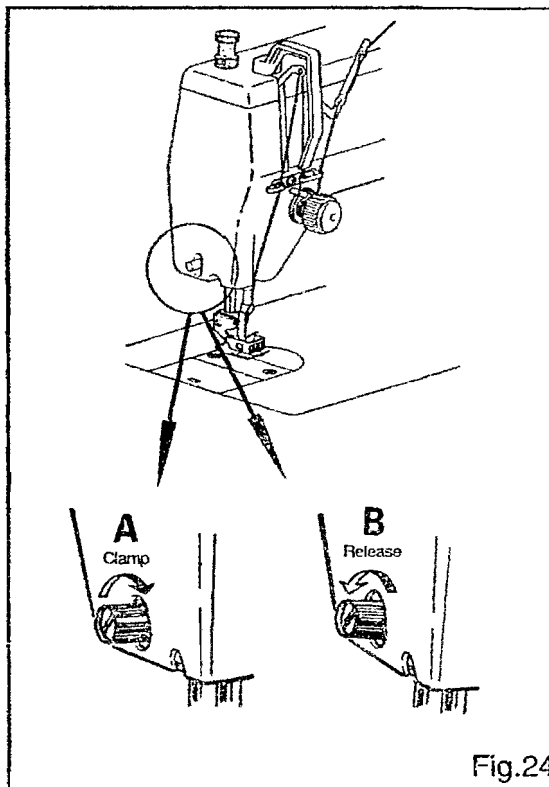
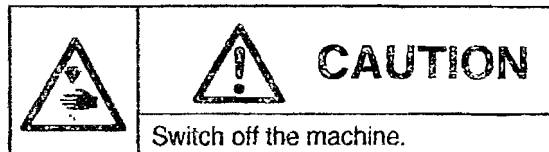

Fig.24.



When linear stitch, turn the linear and locking eccentric sleeve clockwise, secure the needle-bar swaying rack and then the effect of the linear stitching will be better when the curvilinear stitching are made, the eccentric sleeve should be turned counter-clockwise and locked securely onto the machine housing, then release the swaying rack of the needle bar. A, TIGHTEN B, LOOSEN

21. ASSEMBLY OF BELT COVER (Fig.25)

On the table: while the V type belt are in line with belt cover, tighten the screw.

Under the table; after the assemblage of belt cover, the wheel and belt should rotate freely.

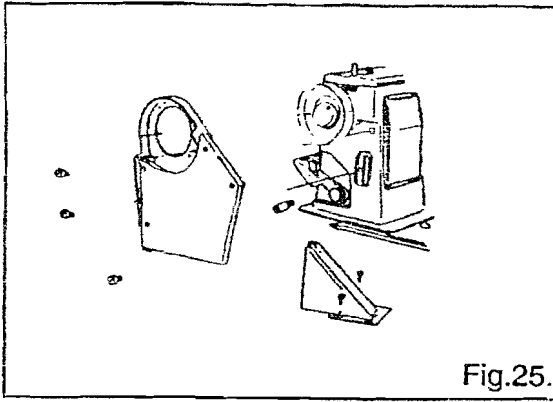

Fig.25.

		<h2>CAUTION</h2>
<p>Switch off the machine. Set sewing head upright again using both hands. Danger of crushing between sewing head and table top. Do not run machine without belt guard! Danger of accidents!</p>		

22.MOUNT KNEE LIFTER (Fig.26)

(20U23/33/43/143/23D/457A/B/D)

1.To assure the convenience of operation, adjust the knee lifter knee plate.

2.In the position of no2, while the no.2 control the no.3, knee can control the sway of needle.
 While the no.2 control the no.4, knee can control the lift of presser foot.

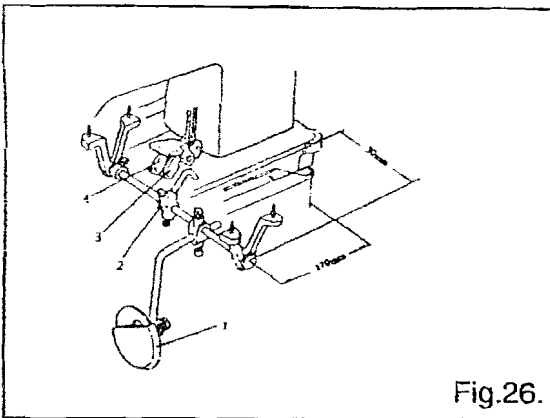

Fig.26.

23.MOUNT KNEE LIFTER (Fig.27, 28,29)

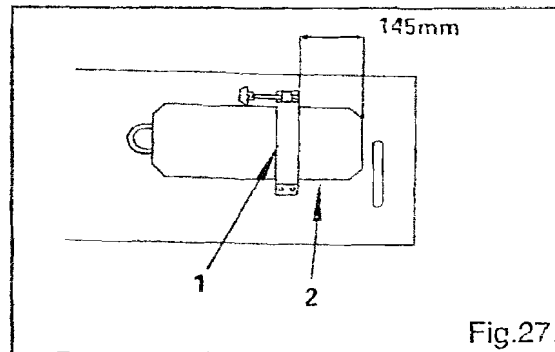

Fig.27.

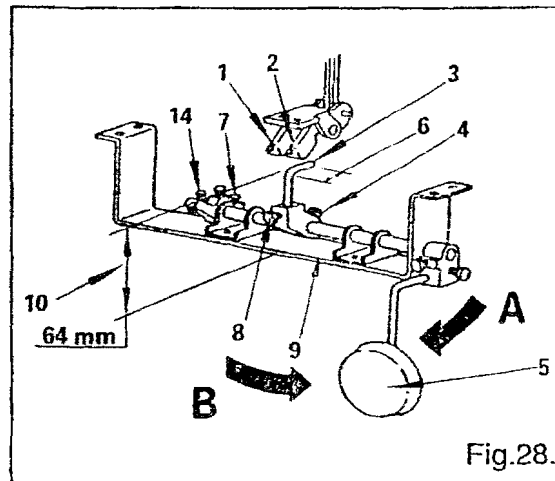

Fig.28.

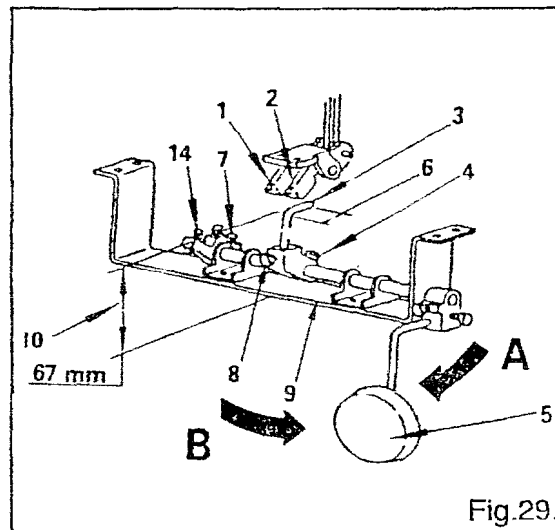
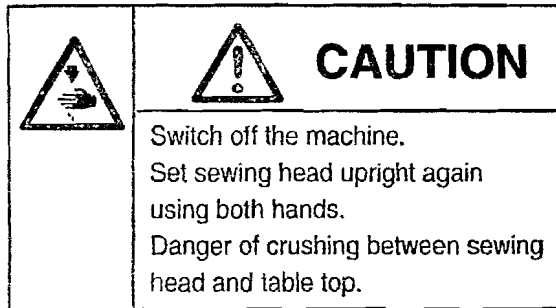

Fig.29.



(20U53/53A/63)

1. Fix the knee lifter stand to the underside of the table 145mm away from the table channel.
2. While turn to figure 27 shows, Knee control the presser to lift or down,
3. While turn to figure 18 shows, Knee control the stitch width.

24. MODES OF SEVERAL SEWING STITCH AND APPLICATION OF ACCESSORY

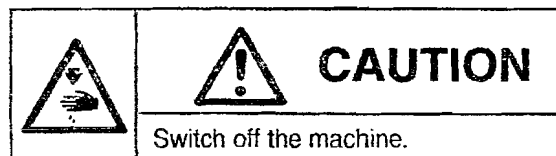
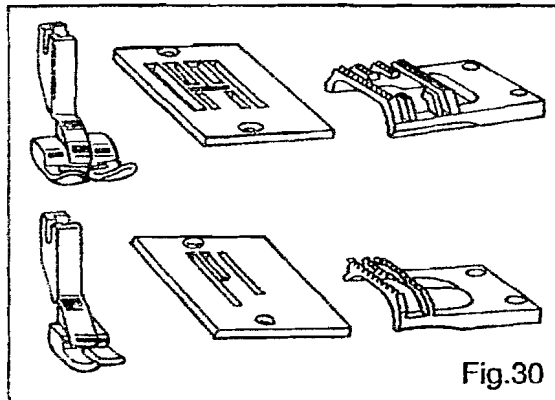

(20U33/43/53/63)

1. LINEAR SEWING

In case of linear sewing, using the linear

sewing presser foot, needle and feeding dog is better than using multi-functional ones.(Fig.30)

While do linear sewing, the horizontal width should be adjust to O position, the linear locking unit with swaying rack of locking needle shaft soft can be used in combination with special presser foot, needle plate and material feeding tooth.

2. EMBROIDERY

Preparation before embroidery

1. it should be noted that any free regulation can be made at the horizontal needle distance between min-max, set the vertical needle distance to O position and will adjust the knee-control parts to make the component control the movement of the sway of meedle.(Fig 27,29)

2. discharge the presser foot and needle plate and feeding dog, then change if with embroidering plate.

3. hold firmly the end of the surface stitches with your left hand, turn the belt pulley manually toward the operator, and then make the bottom stitches pull out from the holes of the needle plate.

4. to make sure to stretch tightly the material between the internal and external embroidering frames, otherwise, maybe cause skipping and stitches-breaking or material creased.(Fig.31)

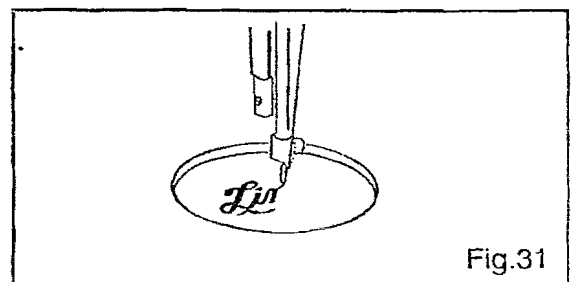

3. ZIPPERED SEWING

This mode is preferable to make use of zippered presser foot (see Fig 32) in a bid to make the stitches more accessible to the projecting stitches, Then release the screw B, regulate the presser foot and set the needle to the presser foot and set the needle to the left and right grooves A of the presser foot. The mode is expected to suit for the sewing.(Fig 33)

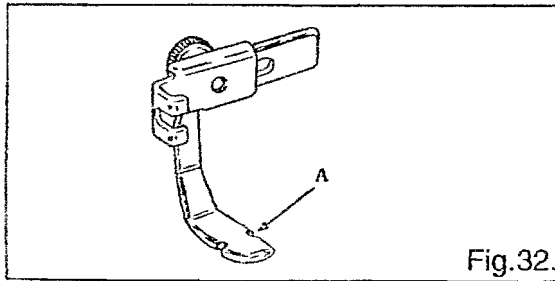

Fig.32.

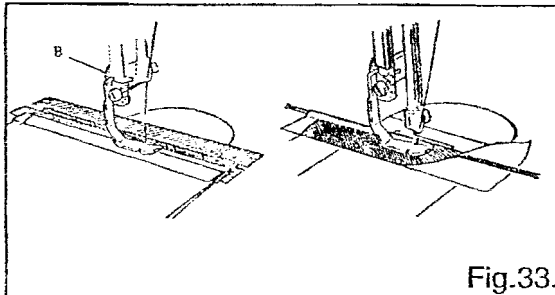

Fig.33.

4.HEM-WRAPPING MODE

In this mode, the hem-wrapping presser foot can be used as we wish(Fig 34). remove the multi-functional presser foot and replace it with the hem-wrapping one.This is also a mode of linear sewing with the needle set to the central position, the hem-wrapping operation can be effected.(Fig. 35)

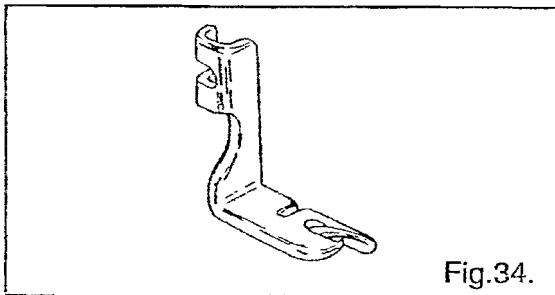

Fig.34.

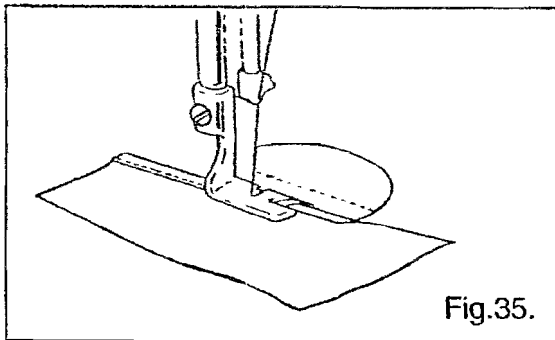

Fig.35.

5.STEM-WRAPPING MODE

During the sewing with the stem-wrapping mode, the special stem-wrapping presser foot, needle plate and material feeding tooth should be put into use(Fig 36), the needle is set to the central position and the horizontal needle distance set to 3mm, and then run thorougher thread through the small groove A on the stem-wrapping presser foot so that the sewing of this mode will be smoothly conducted.

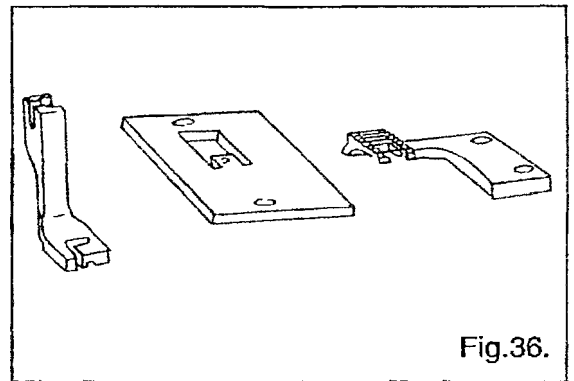

Fig.36.

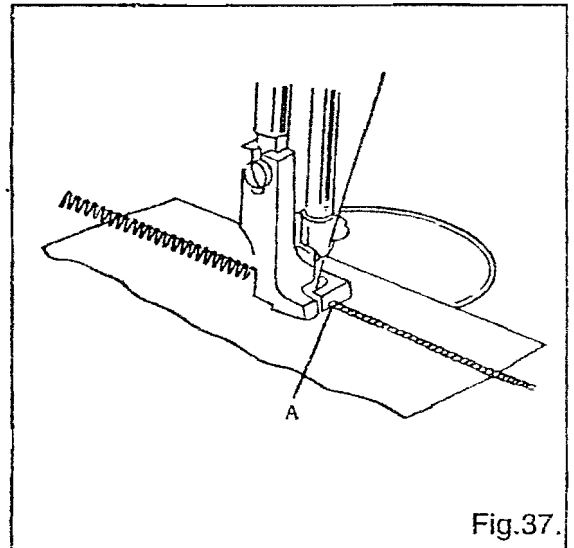

Fig.37.

6.DECORATION SEWING(Fig 38)

If the left, central and right needle positions can be freely changeable and the horizontal needle distance skillfully controlled, the patterns of the decoration sewing will be well achieved.

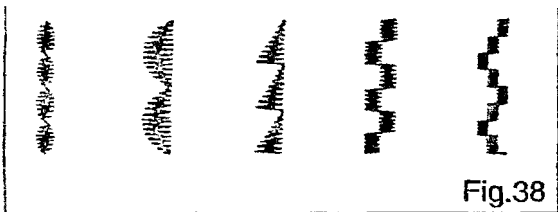

Fig.38

7.OTHER MODES OF PRACTICAL SEWING (Fig.39)

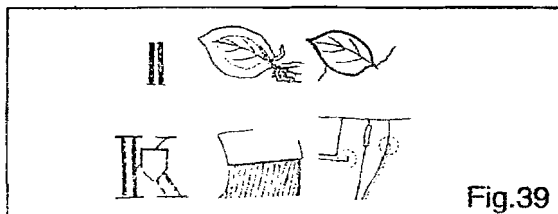

Fig.39

25.MAIN SPECIFICATION

The mode of stitches:see the enclosed
 The mode of machine:see the enclosed

The specification of needle :see upper figure
 The height of hand lifter presser foot:6.35mm
 Upper wheel:model V belt wheel
 The width of work: 211mm(20u143:289mm)
 The height of work:130mm
 The max of needle distance: see the enclosed
 The highest sewing speed: see the enclosed

26.THE MAINTAIN OF MACHINE

The machine should be cleaned periodically to remove lint and fluff which may have accumulated around the working parts. A machine in continuous use should be oiled frequently.

ENCLOSED FIGURE:

model	Stitch modes	Max.of speed	Max.horizontal needle distance	Length of stitches	height of lifter	Addition
20U23		2000.r.p.m	12mm	5.0mm	12mm	
20U23D		2000.r.p.m	6mm			Double needle width 2.5 3.5 4.5(changeable)
20U33		2200.r.p.m	8mm		9mm	
20U43		2000.r.p.m	12mm			
20U53		2500.r.p.m	8mm			
20U63		2000.r.p.m	12mm			
20U53A		2500.r.p.m	8mm			12mm
20U143		2000.r.p.m	12mm		With knife	
457A		2000.r.p.m	8mm			
457B						
457D				Double needle width 2.5 3.5 4.5(changeable)		

CONTENTS

COMPONENTS OF HOUSING.....	1
BOBBIN WINDER,UPPER COVER COMPONENTS.....	3
STITCH-EMBROIDERY COMPONENTS.....	4
THREAD-HOOK COMPONENTS.....	6
THREAD-HOOK COMPONENTS.....	7
MATERIAL-FEEDING COMPONENTS.....	8
DIFFERENTIAL,OIL COMPONENTS.....	9
COMPONENTS OF SWAYING NEEDLE.....	10
COMPONENTS OF SWAYING NEEDLE.....	11
COMPONENTS OF PRESSER FOOT.....	12
COMPONENTS OF NEEDLE DISTANCE OF REVERSAL STITCH.....	13
ACCESSARY.....	14
BELT COVER,THREAD-RUNNING COMPONENTS,BOBBIN WINDER,KNEE LIFTER ASSEMBLY.....	15
STANDBY PARTS.....	16

COMPONENTS OF HOUSING

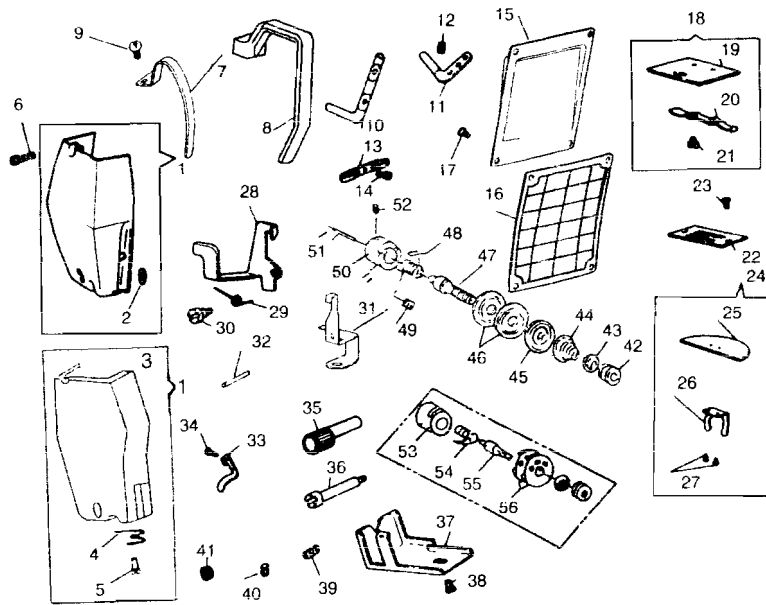

NO	PART NO.										QTY	DESCRIPTION		
		20U23	20U23D	20U33	20U43	20U53	20U63A	20U63	20U143	457A			457B	457D
1	GR245/3-8	*	*	*	*	*	*	*	*	*	*	*	1	Panel components
	GR406/3-8	*	*	*	*	*	*	*	*	*	*	*	1	Panel components
2	GR232-8	*	*	*	*	*	*	*	*	*	*	*	1	Panel thread hook
3	GK158-8	*	*	*	*	*	*	*	*	*	*	*	1	Panel
4	GW242-8	*	*	*	*	*	*	*	*	*	*	*	1	Panel thread hook
5	GZ374-8	*	*	*	*	*	*	*	*	*	*	*	1	Panel thread hook needle
6	GS132-8	*	*	*	*	*	*	*	*	*	*	*	2	Panel screw
	GS375-8	*	*	*	*	*	*	*	*	*	*	*	2	Panel screw
7	GK134-8	*	*	*	*	*	*	*	*	*	*	*	1	Stitch-staff shield
	GK146-8	*	*	*	*	*	*	*	*	*	*	*	1	Stitch-staff shield
	GK140-8	*	*	*	*	*	*	*	*	*	*	*	1	Stitch-staff shield
8	GK161-8	*	*	*	*	*	*	*	*	*	*	*	1	Stitch -staff shield
9	GS223-8	*	*	*	*	*	*	*	*	*	*	*	1	Stitch-staff shield screw
	GS379-8	*	*	*	*	*	*	*	*	*	*	*	1	Stitch-staff shield screw
10	GR412-8	*	*	*	*	*	*	*	*	*	*	*	1	Double hole thread-running rack
11	GR233-8	*	*	*	*	*	*	*	*	*	*	*	1	3-eyelet hole thread hook
	GR364-8	*	*	*	*	*	*	*	*	*	*	*	1	2-eyelet hole thread hook
12	GS139-8	*	*	*	*	*	*	*	*	*	*	*	1	3-eyelet hole thread hook screw
13	GR231-8	*	*	*	*	*	*	*	*	*	*	*	1	Thread-running rack
14	GS223-8	*	*	*	*	*	*	*	*	*	*	*	1	Thread-running rack screw
15	GK133-8	*	*	*	*	*	*	*	*	*	*	*	1	Back cover
	GK145-8	*	*	*	*	*	*	*	*	*	*	*	1	Back cover
16	GK160-8	*	*	*	*	*	*	*	*	*	*	*	1	Back cover
17	GS132-8	*	*	*	*	*	*	*	*	*	*	*	4	Back cover screw
18	GR476/4-8	*	*	*	*	*	*	*	*	*	*	*	1	Pushing plate components
19	GM132-8	*	*	*	*	*	*	*	*	*	*	*	1	Pushing plate
20	GW131-8	*	*	*	*	*	*	*	*	*	*	*	1	Pushing plate spring
21	GS133-8	*	*	*	*	*	*	*	*	*	*	*	2	Pushing plate spring screw
22	GM131-8	*	*	*	*	*	*	*	*	*	*	*	1	Needle plate
	GM156-8	*	*	*	*	*	*	*	*	*	*	*	1	Needle plate
	GM205-8	*	*	*	*	*	*	*	*	*	*	*	1	Needle plate
23	GS338-8	*	*	*	*	*	*	*	*	*	*	*	2	Needle plate screw
24	GR477/4-8	*	*	*	*	*	*	*	*	*	*	*	1	Inner cover plate components
25	GM130-8	*	*	*	*	*	*	*	*	*	*	*	1	Inner cover plate
26	GW130-8	*	*	*	*	*	*	*	*	*	*	*	1	inner cover plate spring
27	GS255-8	*	*	*	*	*	*	*	*	*	*	*	2	Inner cover plate screw
28	GR241-8	*	*	*	*	*	*	*	*	*	*	*	1	Thread-releasing lever
	GR373-8	*	*	*	*	*	*	*	*	*	*	*	1	Thread-releasing lever
29	GW135-8	*	*	*	*	*	*	*	*	*	*	*	1	Thread-teleasing lever spring
30	GS148-8	*	*	*	*	*	*	*	*	*	*	*	1	Thread-teleasing lever screw
31	GR397-8	*	*	*	*	*	*	*	*	*	*	*	1	Locating base of presser
32	GX180-8	*	*	*	*	*	*	*	*	*	*	*	1	Lower thread-running hook
33	GR230-8	*	*	*	*	*	*	*	*	*	*	*	1	Lower thread-running hook
34	GS137-8	*	*	*	*	*	*	*	*	*	*	*	1	Lower thread-running screw
35	GT150-8	*	*	*	*	*	*	*	*	*	*	*	1	Linear lock eccentric shield

NO	PART NO.													QTY	DESCRIPTION			
		20U23	20U23D	20U33	20U43	20U53	20L53A	20U63	20U143	457A	457B	457D						
36	GS264-8	*	*	*	*	*	*	*	*	*	*	*	*	*	*	*	1	Linear lock eccentric shield screw
37	GK130-8	*	*	*	*	*	*	*	*	*	*	*	*	*	*	*	1	Rotating shuttle shield
38	GS132-8	*	*	*	*	*	*	*	*	*	*	*	*	*	*	*	1	Rotating shuttle shield screw
39	GX191-8	*	*	*	*	*	*	*	*	*	*	*	*	*	*	*	1	Eccentric shield stress ploe
40	GW179-8	*	*	*	*	*	*	*	*	*	*	*	*	*	*	*	1	eccentric shield stress spring
41	GS288-8	*	*	*	*	*	*	*	*	*	*	*	*	*	*	*	1	Stress spring screw
42	GL130-8	*	*	*	*	*	*	*	*	*	*	*	*	*	*	*	1	Thread-holding nut
	GL176-8	*	*	*	*	*	*	*	*	*	*	*	*	*	*	*	1	Thread-holding nut
43	GR239-8	*	*	*	*	*	*	*	*	*	*	*	*	*	*	*	1	Thread-holding brake
44	GW133-8	*	*	*	*	*	*	*	*	*	*	*	*	*	*	*	1	Thread-holding spring
	GW208-8	*	*	*	*	*	*	*	*	*	*	*	*	*	*	*	1	Thread-holding spring
45	GR238-8	*	*	*	*	*	*	*	*	*	*	*	*	*	*	*	1	Thread-releasing plate
46	GR237-8	*	*	*	*	*	*	*	*	*	*	*	*	*	*	*	2	Thread-holding plate
47	GS145-8	*	*	*	*	*	*	*	*	*	*	*	*	*	*	*	1	Thread-holding screw
48	GW134-8	*	*	*	*	*	*	*	*	*	*	*	*	*	*	*	1	Stitch spring
49	GS146-8	*	*	*	*	*	*	*	*	*	*	*	*	*	*	*	1	Thread-holding fixing screw
50	GR372-8	*	*	*	*	*	*	*	*	*	*	*	*	*	*	*	1	Stitch-spring adjusting base
51	GX132-8	*	*	*	*	*	*	*	*	*	*	*	*	*	*	*	1	Thread-releasing needle
52	GS147-8	*	*	*	*	*	*	*	*	*	*	*	*	*	*	*	1	Thread-hold fixing screw
53	GR370-8	*	*	*	*	*	*	*	*	*	*	*	*	*	*	*	1	Stitch spring adjuster
54	GW170-8	*	*	*	*	*	*	*	*	*	*	*	*	*	*	*	1	Stitch spring
55	GS261-8	*	*	*	*	*	*	*	*	*	*	*	*	*	*	*	1	Stitch spring screw
56	GR367/3-8	*	*	*	*	*	*	*	*	*	*	*	*	*	*	*	2	Stitch-guiding part

BOBBIN WINDER, UPPER COVER COMPONENTS

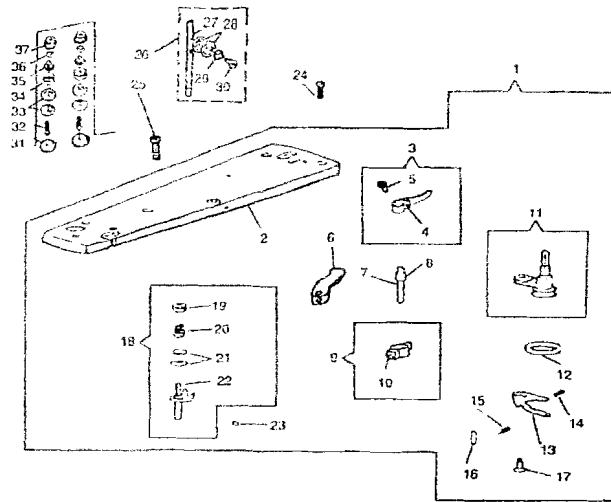

NO	PART NO.	20U23	20U29D	20U33	20U43	20U53	20U53A	20U53	20U143	457A	457B	457D	QTY	DESCRIPTION
1	GR483/27-8	-	-	-	-	-	-	-	-	-	-	-	1	Upper cover components
	GR781/28-8	-	-	-	-	-	-	-	-	-	-	-	1	Upper cover components
2	GK132-8	-	-	-	-	-	-	-	-	-	-	-	1	Upper cover
	GK141-8	-	-	-	-	-	-	-	-	-	-	-	1	Upper cover
	GK148-8	-	-	-	-	-	-	-	-	-	-	-	1	Upper cover
	CK155-8	-	-	-	-	-	-	-	-	-	-	-	1	Upper cover
	GK147-8	-	-	-	-	-	-	-	-	-	-	-	1	Upper cover
3	GR480/2-8	-	-	-	-	-	-	-	-	-	-	-	1	Volume adjusting plate components
4	GR377-8	-	-	-	-	-	-	-	-	-	-	-	1	Volume adjusting plate
5	GS273-8	-	-	-	-	-	-	-	-	-	-	-	1	Volume adjusting plate screw
6	GR726-8	-	-	-	-	-	-	-	-	-	-	-	1	Volume adjusting plate
7	GZ202-8	-	-	-	-	-	-	-	-	-	-	-	1	Volume adjusting spindle
	GZ246-8	-	-	-	-	-	-	-	-	-	-	-	1	Volume adjusting spindle
8	GO219-8	-	-	-	-	-	-	-	-	-	-	-	1	Washer
9	CR4R1/2-8	-	-	-	-	-	-	-	-	-	-	-	1	Locating block
10	GS222-8	-	-	-	-	-	-	-	-	-	-	-	1	Locating block set screw
11	GR405/8-8	-	-	-	-	-	-	-	-	-	-	-	1	Axis components
	GR780/9-8	-	-	-	-	-	-	-	-	-	-	-	1	Axis components
12	GO207-8	-	-	-	-	-	-	-	-	-	-	-	1	Rubber circle
	GO284-8	-	-	-	-	-	-	-	-	-	-	-	1	Rubber circle
13	GR375-8	-	-	-	-	-	-	-	-	-	-	-	1	Thread-winding swaying handle
14	GW175-8	-	-	-	-	-	-	-	-	-	-	-	1	Swaying handle presser spring
15	GW174-8	-	-	-	-	-	-	-	-	-	-	-	1	Swaying handle presser spring
16	GX182-8	-	-	-	-	-	-	-	-	-	-	-	1	Extension spring pin
17	GS272-8	-	-	-	-	-	-	-	-	-	-	-	1	Crank screw
	GX218-8	-	-	-	-	-	-	-	-	-	-	-	1	Crank screw
18	GR482/6-8	-	-	-	-	-	-	-	-	-	-	-	1	Upper thread-running plate
	GR778/6-8	-	-	-	-	-	-	-	-	-	-	-	1	Upper thread-running plate
19	GL162-8	-	-	-	-	-	-	-	-	-	-	-	1	Upper thread-running plate nut
	GL175-8	-	-	-	-	-	-	-	-	-	-	-	1	Upper thread-running plate nut
20	GW175-8	-	-	-	-	-	-	-	-	-	-	-	1	Upper thread-running plate spring
21	GR379-8	-	-	-	-	-	-	-	-	-	-	-	2	Upper thread-running pole
22	GR403/2-8	-	-	-	-	-	-	-	-	-	-	-	1	Upper thread-running plate components
23	GS275-8	-	-	-	-	-	-	-	-	-	-	-	1	Fixing screw
24	GS142-8	-	-	-	-	-	-	-	-	-	-	-	1	Upper cover back screw
25	GS140-8	-	-	-	-	-	-	-	-	-	-	-	1	Upper cover set screw
	GS376-8	-	-	-	-	-	-	-	-	-	-	-	2	Upper cover screw
26	GR234/5-8	-	-	-	-	-	-	-	-	-	-	-	1	Thread-running components
27	GR235-8	-	-	-	-	-	-	-	-	-	-	-	1	Thread-running pole
	GR365-8	-	-	-	-	-	-	-	-	-	-	-	1	Thread-running pole
28	GR236-8	-	-	-	-	-	-	-	-	-	-	-	2	Thread-running plate
29	GW132-8	-	-	-	-	-	-	-	-	-	-	-	1	Thread-running spring
30	GS141-8	-	-	-	-	-	-	-	-	-	-	-	1	Thread-running holding screw
31	GL160-8	-	-	-	-	-	-	-	-	-	-	-	2	Thread-holding nut
32	GS260-8	-	-	-	-	-	-	-	-	-	-	-	2	Thread-holding screw
33	GR237-8	-	-	-	-	-	-	-	-	-	-	-	4	Thread-holding plate
34	GR369-8	-	-	-	-	-	-	-	-	-	-	-	2	Thread-holding spring
35	GW133-8	-	-	-	-	-	-	-	-	-	-	-	2	Thread-holding spring
36	GR239-8	-	-	-	-	-	-	-	-	-	-	-	2	Thread-holding brake
37	GL160-8	-	-	-	-	-	-	-	-	-	-	-	2	Thread-holding nut

STITCH-EMBROIDERY COMPONENTS

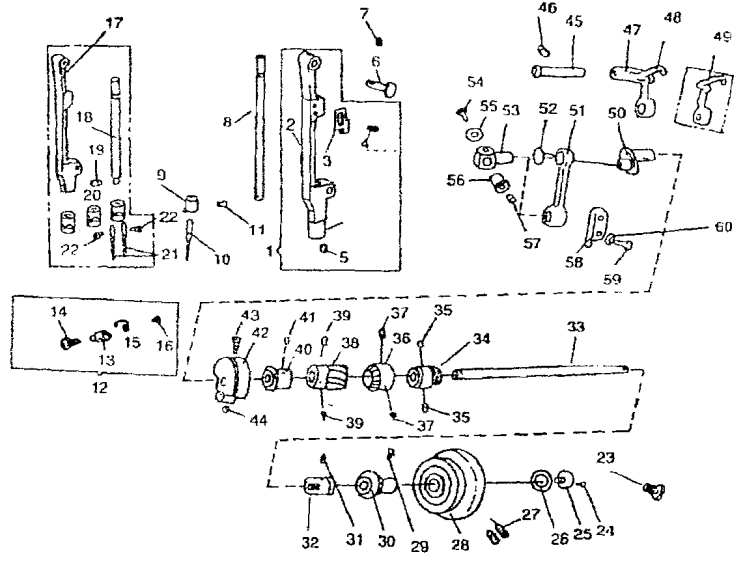

NO	PART NO.											QTY	DESCRIPTION		
		20U23	20U20	20U33	20U43	20U63	20U53A	20U63	20U143	457A	457B			457D	
1	GR485/5-8	*	*	*	*	*	*	*	*	*	*	*	*	1	Swaying rack of needle staff components
2	GR251-8	*	*	*	*	*	*	*	*	*	*	*	*	1	Swaying rack of needle staff
3	GR255-8	*	*	*	*	*	*	*	*	*	*	*	*	1	Locating plate of needle staff
4	GS163-8	*	*	*	*	*	*	*	*	*	*	*	*	2	Locating plate screw
5	GS158-8	*	*	*	*	*	*	*	*	*	*	*	*	1	Eccentric pin screw of needle staff
6	GX143-8	*	*	*	*	*	*	*	*	*	*	*	*	1	Pin of swaying rack
7	GS164-8	*	*	*	*	*	*	*	*	*	*	*	*	1	Pin of swaying rack screw
8	GZ223-8	*	*	*	*	*	*	*	*	*	*	*	*	1	Needle bar
	GZ140-8	*	*	*	*	*	*	*	*	*	*	*	*	1	Needle bar
9	GR252-8	*	*	*	*	*	*	*	*	*	*	*	*	1	Thread-hook of needle staff
10	GV130-8	*	*	*	*	*	*	*	*	*	*	*	*	1	Needle
11	GS159-8	*	*	*	*	*	*	*	*	*	*	*	*	1	Locking screw of needle
12	GR484/4-8	*	*	*	*	*	*	*	*	*	*	*	*	1	Needle clamp components
13	GR467-8	*	*	*	*	*	*	*	*	*	*	*	*	1	Needle clamp
14	GS290-8	*	*	*	*	*	*	*	*	*	*	*	*	1	Thread-hook screw
15	GR466-8	*	*	*	*	*	*	*	*	*	*	*	*	1	Thread-hook of needle staff
16	GS289-8	*	*	*	*	*	*	*	*	*	*	*	*	1	Needle lock screw
17	GR361-8	*	*	*	*	*	*	*	*	*	*	*	*	1	Needle bar swaying rack
18	GZ200-8	*	*	*	*	*	*	*	*	*	*	*	*	1	Double needle needle bar
19	GS202-8	*	*	*	*	*	*	*	*	*	*	*	*	1	Double needle clamber lock screw
20	GR360-8	*	*	*	*	*	*	*	*	*	*	*	*	1	Double needle clamber A
	GR360B-8	*	*	*	*	*	*	*	*	*	*	*	*	1	Double needle clamber B
	GR360C-8	*	*	*	*	*	*	*	*	*	*	*	*	1	Double needle clamber C
21	GV130-8	*	*	*	*	*	*	*	*	*	*	*	*	2	Needle
22	GS262-8	*	*	*	*	*	*	*	*	*	*	*	*	2	Needle lock screw
23	GS254-8	*	*	*	*	*	*	*	*	*	*	*	*	1	Clamping screw of upper wheel
24	GS279-8	*	*	*	*	*	*	*	*	*	*	*	*	1	Clutch little screw
25	GS278-8	*	*	*	*	*	*	*	*	*	*	*	*	1	Clutch screw
	GP151-8	*	*	*	*	*	*	*	*	*	*	*	*	1	Clutch wheel
26	GR380-8	*	*	*	*	*	*	*	*	*	*	*	*	1	Clutch washer
27	GS200-8	*	*	*	*	*	*	*	*	*	*	*	*	2	Upper wheel lock screw
28	GP142-8	*	*	*	*	*	*	*	*	*	*	*	*	1	Upper wheel
	GP130-8	*	*	*	*	*	*	*	*	*	*	*	*	1	Upper wheel
29	GS280-8	*	*	*	*	*	*	*	*	*	*	*	*	1	Sleeve screw
30	GO209-8	*	*	*	*	*	*	*	*	*	*	*	*	1	Sleeve of upper wheel
31	GS277-8	*	*	*	*	*	*	*	*	*	*	*	*	1	Back sleeve of upper shaft
	GS173-8	*	*	*	*	*	*	*	*	*	*	*	*	1	Fastening screw of back sleeve
32	GO208-8	*	*	*	*	*	*	*	*	*	*	*	*	1	Back sleeve of upper shaft
	GO144-8	*	*	*	*	*	*	*	*	*	*	*	*	1	Back sleeve of upper shaft
33	GZ141-8	*	*	*	*	*	*	*	*	*	*	*	*	1	Upper shaft
	GZ207-8	*	*	*	*	*	*	*	*	*	*	*	*	1	Upper shaft
	GZ203-8	*	*	*	*	*	*	*	*	*	*	*	*	1	Upper shaft
	GZ248-8	*	*	*	*	*	*	*	*	*	*	*	*	1	Upper shaft
34	GT153-8	*	*	*	*	*	*	*	*	*	*	*	*	1	Cam of cloth-feeding
35	GS251-8	*	*	*	*	*	*	*	*	*	*	*	*	2	Cam of cloth-feeding screw

NO	PART NO.											QTY	DESCRIPTION			
		20U63	20U23D	20U93	20U43	20U63	20U63A	20U63	20U143	437A	457B			457D		
36	GC131-8														1	Arc-cone gear (upper shaft)
37	GS167-8														2	Screw of are-cone gear
38	GC130-8														1	Spiral of gear of upper shaft
	GC148-8														1	Spiral of gear of upper shaft
39	GS170-8														1	Screw of spiral gear
40	GO143-8														1	Front sleeve of upper shaft
41	GS169-8														1	Fastening screw of front sleeve
42	GH145-8														1	Stitch crank
43	GS168-8														1	Stitch crank screw
44	GS404-8														2	Crank fastening screw
45	GX144-8														1	Pin of swaying staff
46	GS147-8														1	Screw of swaying staff
47	GH141-8														1	Stitch-swaying staff
48	GH143-8														1	Stitch-staff
49	GH200-8														1	Stitch-staff
50	GH144-8														1	Crank of needle staff
51	GH140-8														1	Small connecting staff
52	GS166-8														1	Toothed screw
53	GR253-8														1	Connecting shaft
54	GS161-8														1	Pin-screw of needle
55	GO141-8														1	Pin-washer of connecting shaft
56	GZ142-8														1	Pin of connecting shaft
57	GS160-8														1	Pin-locking screw of connecting shaft
58	GK254-8														1	Guide of small of connecting staff
59	GS132-8														2	Screw of guide
60	GO217-8														2	Guide washer

THREAD-HOOK COMPONENTS

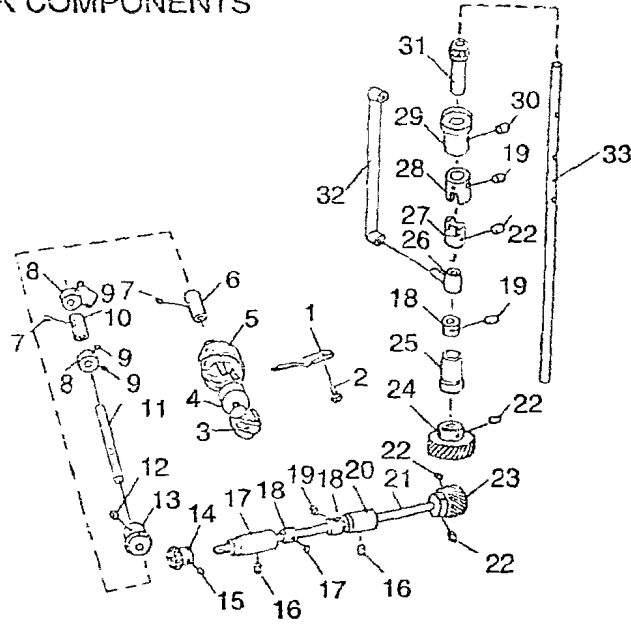

NO	PART NO.											QTY	DESCRIPTION				
		20U23	20U23D	20U33	20U43	20U53	20U53A	20U63	20U143	457A	457B			457D			
1	GR278-8	*	*		*											1	Locating plate of rotating shuttle
2	GS256-8	*	*		*			*								1	Screw of locating plate
3	GM131-8	*	*		*			*								1	Shuttle
4	GN135-8	*	*		*			*								1	Shuttle core
5	GN130-8	*	*		*			*								1	Rotating shuttle
6	GO163-8	*	*		*			*								1	Front sleeve of rotating shuttle shaft
7	GS201-8	*	*		*			*								2	Screw of front sleeve
8	GO164-8	*	*		*			*								2	Retainer of rotating shuttle shaft
9	GS202-8	*	*		*			*								4	Retainer screw
10	GO165-8	*	*		*			*								1	Back sleeve of rotating shuttle shaft
11	GZ164-8	*	*		*			*								1	Rotating shuttle shaft
12	GS167-8	*	*		*			*								2	Screw arc-cone gear
13	GC141-8	*	*		*			*								1	Arc-cone gear of rotating shuttle shaft
14	GC140-8	*	*		*			*								1	Arc-cone gear of lower shaft
15	GS199-8	*	*		*			*								2	Screw of arc-cone gear
16	GS147-8	*	*		*			*								2	Screw
17	GO162-8	*	*		*			*								1	Front sleeve of lower shaft
18	GO216-8															1	Front sleeve of lower shaft
19	GO158-8	*	*		*			*								3	Lower shaft retainer
20	GO161-8	*	*		*			*								6	Retainer screw of lower shaft
21	GO215-8															1	Back sleeve of lower shaft
22	GZ163-8	*	*		*			*								1	Lower shaft
23	GZ210-8															1	Lower shaft
24	GS167-8	*	*		*			*								6	Screw of differential gear
25	GC139-8	*	*		*			*								1	Differential gear
26	GC137-8	*	*		*			*								1	Differential gear
27	GO159-8	*	*		*			*								1	Lower sleeve of vertical shaft
28	GO157-8	*	*		*			*								1	Differential shaft sliding-cover
29	GO156-8	*	*		*			*								1	Lower clutch sleeve
30	GO155-8	*	*		*			*								1	Upper clutch sleeve
31	GO154-8	*	*		*			*								1	Upper sleeve of vertical shaft
32	GS198-8	*	*		*			*								1	Screw of upper sleeve
33	GC136-8	*	*		*			*								1	Arc-cone gear
34	GH168-8	*	*		*			*								1	Differential connecting bar
35	GZ162-8	*	*		*			*								1	Vertical shaft

COMPONENTS OF SWAYING NEEDLE

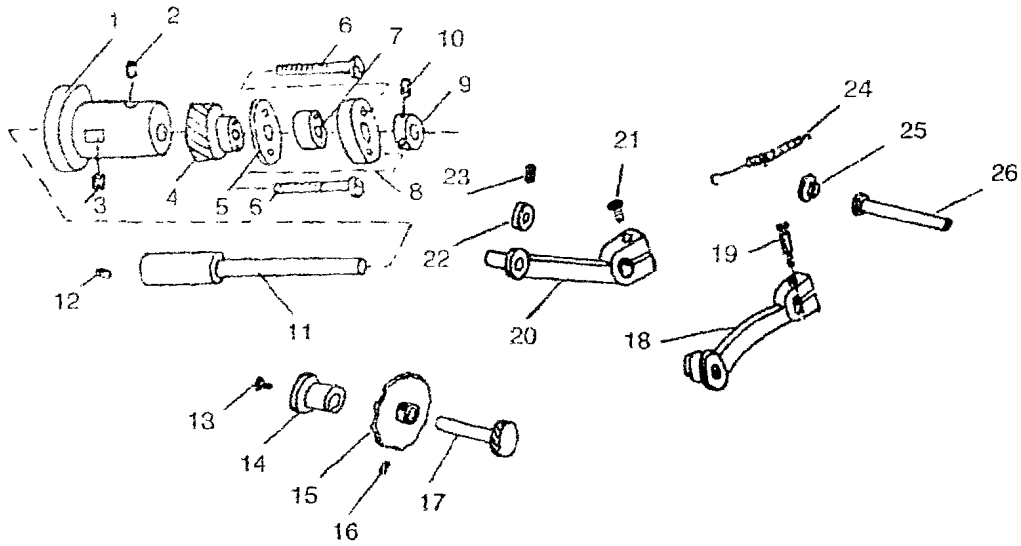

NO	PART NO.											QTY	DESCRIPTION			
		20L23	20L23D	20L33	20L43	20L53	20L53A	20L63	20L143	451A	457B			457D		
1	GO150-8	-	-	-	-	-	-	-	-	-	-	-	-	-	1	Sleeve of swaying needle
2	GS199-8	-	-	-	-	-	-	-	-	-	-	-	-	-	1	Fastening screw of swaying needle shaft
3	GS147-8	-	-	-	-	-	-	-	-	-	-	-	-	-	1	Screw of sleeve of swaying needle
4	GC146-8	-	-	-	-	-	-	-	-	-	-	-	-	-	1	Gear of swaying needle
5	GO181-8	-	-	-	-	-	-	-	-	-	-	-	-	-	1	Eccentric retainer
	GO212-8	-	-	-	-	-	-	-	-	-	-	-	-	-	1	Eccentric retainer
6	GS221-8	-	-	-	-	-	-	-	-	-	-	-	-	-	2	Connecting screw of eccentric cam
7	GT145-8	-	-	-	-	-	-	-	-	-	-	-	-	-	1	Eccentric cam
	GT151-8	-	-	-	-	-	-	-	-	-	-	-	-	-	1	Eccentric cam
8	GO182-8	-	-	-	-	-	-	-	-	-	-	-	-	-	1	Back retainer of eccentric cam
	GO213-8	-	-	-	-	-	-	-	-	-	-	-	-	-	1	Back retainer of eccentric cam
9	GO183-8	-	-	-	-	-	-	-	-	-	-	-	-	-	1	Retainer of swaying needle shaft
10	GS223-8	-	-	-	-	-	-	-	-	-	-	-	-	-	2	Screw of retainer of swaying shaft
11	GZ177-8	-	-	-	-	-	-	-	-	-	-	-	-	-	1	Swaying needle shaft
	GZ203-8	-	-	-	-	-	-	-	-	-	-	-	-	-	1	Swaying needle shaft
	GZ219-8	-	-	-	-	-	-	-	-	-	-	-	-	-	1	Swaying needle shaft
12	GS147-8	-	-	-	-	-	-	-	-	-	-	-	-	-	1	Screw of swaying needle shaft
13	GS166-8	-	-	-	-	-	-	-	-	-	-	-	-	-	1	Left-hand screw
14	GO226-8	-	-	-	-	-	-	-	-	-	-	-	-	-	1	Leaning gear sleeve
15	GR461/2-8	-	-	-	-	-	-	-	-	-	-	-	-	-	1	Cam component
	GR1314/2-8	-	-	-	-	-	-	-	-	-	-	-	-	-	1	Cam component
16	GS202-8	-	-	-	-	-	-	-	-	-	-	-	-	-	1	Sleeve screw of cam component
17	GC149-8	-	-	-	-	-	-	-	-	-	-	-	-	-	1	Leaning gear
	GC175-8	-	-	-	-	-	-	-	-	-	-	-	-	-	1	Leaning gear
18	GR458/3-8	-	-	-	-	-	-	-	-	-	-	-	-	-	1	Regulator fork drive lever component
19	GS285-8	-	-	-	-	-	-	-	-	-	-	-	-	-	1	Screw of drive lever
20	GR460/3-8	-	-	-	-	-	-	-	-	-	-	-	-	-	1	Following lever component
21	GS020	-	-	-	-	-	-	-	-	-	-	-	-	-	1	Screw of following lever
22	GO164-8	-	-	-	-	-	-	-	-	-	-	-	-	-	1	Washer of following lever
23	GS292-8	-	-	-	-	-	-	-	-	-	-	-	-	-	1	Washer screw
24	GW178-8	-	-	-	-	-	-	-	-	-	-	-	-	-	1	Spring
25	GR243	-	-	-	-	-	-	-	-	-	-	-	-	-	1	Rubber cap
26	GZ222-8	-	-	-	-	-	-	-	-	-	-	-	-	-	1	Following shaft

COMPONENTS OF PRESSER FOOT

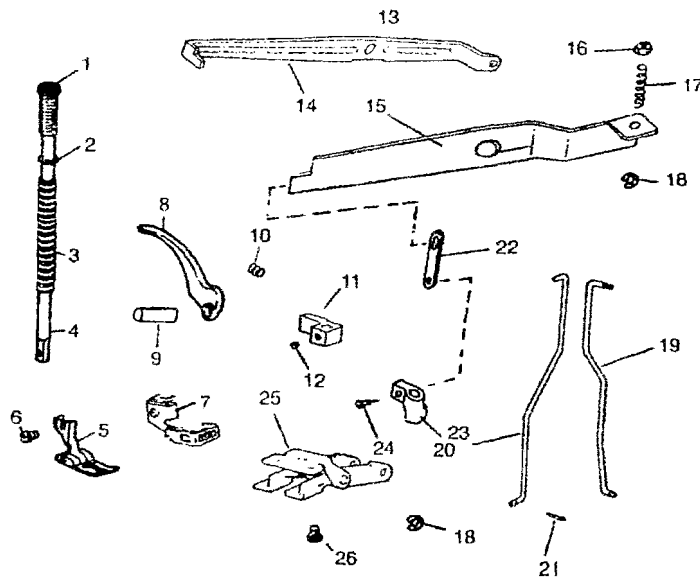

NO	PART NO.	20U23	20U23D	20U33	20U43	20U53	20U53A	20U63	20U143	457A	457B	457D	QTY	DESCRIPTION
1	GS234-8	*	*	*	*	*	*	*	*	*	*	*	1	Screw for presser-adjusting
	GS384-8	-	-	-	-	-	-	-	-	-	-	-	1	Screw for presser-adjusting
2	GC178-8	-	-	-	-	-	-	-	-	-	-	-	1	Screw for presser-adjusting
3	GW153-8	*	*	*	*	*	*	*	*	*	*	*	1	Presser bar spring
4	GZ187-8	*	*	*	*	*	*	*	*	*	*	*	1	Presser bar
5	GR465/4-8	*	*	*	*	*	*	*	*	*	*	*	1	Presser foot component
	GR327/4-8	*	*	*	*	*	*	*	*	*	*	*	1	Presser foot component
6	GS231-8	*	*	*	*	*	*	*	*	*	*	*	1	Screw of presser foot
7	GR1000-8	-	-	-	-	-	-	-	-	-	-	-	1	Finger guard
	GR1001-8	-	-	-	-	-	-	-	-	-	-	-	1	Finger guard
8	GR322-8	*	*	*	*	*	*	*	*	*	*	*	1	Spanner
	GR733-8	-	-	-	-	-	-	-	-	-	-	-	1	Spanner
9	GX183-8	-	-	-	-	-	-	-	-	-	-	-	1	Spanner pin
	GX166-8	*	*	*	*	*	*	*	*	*	*	*	1	Spanner pin
10	GS232-8	*	*	*	*	*	*	*	*	*	*	*	1	Spanner pin screw
	GR324-8	*	*	*	*	*	*	*	*	*	*	*	1	Presser bar bracket
	GR398-8	-	-	-	-	-	-	-	-	-	-	-	1	Presser bar bracket
12	GS232-8	*	*	*	*	*	*	*	*	*	*	*	1	Screw of bracket
13	GS235-8	*	*	*	*	*	*	*	*	*	*	*	1	Screw of presser foot lever
14	GZ204-8	-	-	-	-	-	-	-	-	-	-	-	1	Presser foot lever
	GZ217-8	-	-	-	-	-	-	-	-	-	-	-	1	Presser foot lever
15	GZ188-8	*	*	*	*	*	*	*	*	*	*	*	1	Presser foot lever
16	GL154-8	*	*	*	*	*	*	*	*	*	*	*	1	Presser bar nut
17	GW154-8	*	*	*	*	*	*	*	*	*	*	*	1	Presser bar spring
18	GO193-8	*	*	*	*	*	*	*	*	*	*	*	2	Presser bar washer
19	GZ190-8	*	*	*	*	*	*	*	*	*	*	*	1	Rod of horizontal needle
	GZ206-8	*	*	*	*	*	*	*	*	*	*	*	1	Rod of horizontal needle
20	GZ189-8	*	*	*	*	*	*	*	*	*	*	*	1	Rod of presser foot
	GZ205-8	*	*	*	*	*	*	*	*	*	*	*	1	Rod of presser foot
21	GX184-8	-	-	-	-	-	-	-	-	-	-	-	3	Open-pin
22	GH191-8	*	*	*	*	*	*	*	*	*	*	*	1	Connecting bar
23	GR323-8	*	*	*	*	*	*	*	*	*	*	*	1	Locating base of plate
24	GS233-8	*	*	*	*	*	*	*	*	*	*	*	1	Screw of connecting bar
25	GR328/10-8	*	*	*	*	*	*	*	*	*	*	*	1	Knee-control locating base component
26	GS236-8	*	*	*	*	*	*	*	*	*	*	*	1	Knee-control lever base screw

COMPONENTS OF NEEDLE DISTANCE OF REVERSAL STITCH

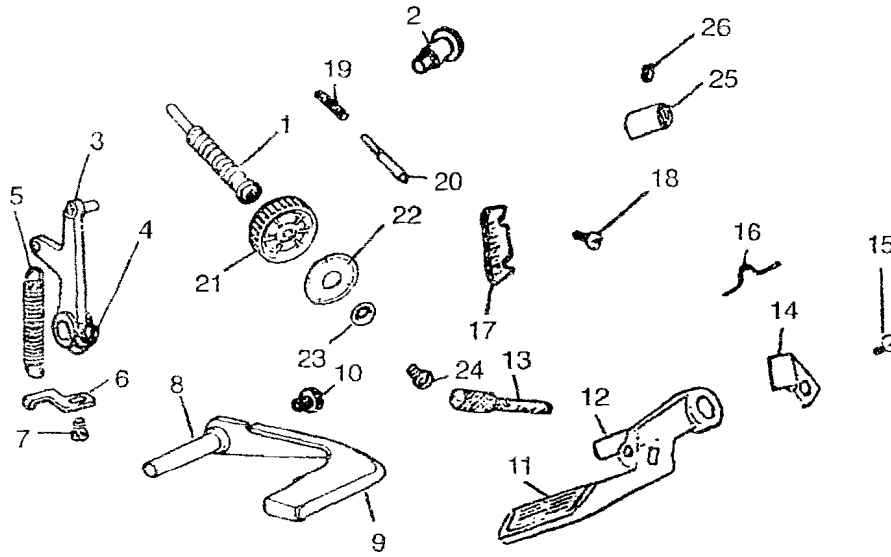

NO	PART NO											QTY	DESCRIPTION			
		20U23	20U23D	20U33	27U43	20U53	20U53A	20U63	20U143	457A	457B			457D		
1	C3245-8														1	Adjusting screw for needle distance
2	GR413-8														1	Adjusting screw for needle distance
3	GX177-8														1	Needle distance base pin
4	GR342-2-8														1	Crank component
5	GS142-8														1	Crank screw
6	GW166-8														1	Restoring extension spring of reversal stitch
7	GR339-8														1	Spring hook
8	GS256-8														1	Screw of spring hook
9	GX178-8														1	Reversal stitch spanner shaft
10	GR338-8														1	Spanner of reversal stitch
11	GS247-8														1	Screw of spanner
12	GR735-8														1	Spanner of reversal stitch
13	GZ249-8														1	Reversal stitch spanner shaft
14	GS385-8														1	Regulating screw of reversal stitch
15	GR736-8														1	Regulating plate of reversal stitch
16	GS386-8														1	Screw of regulating plate
17	GW200-8														1	Regulating screw clamping spring
18	GR737-8														1	Feed reverse regulating indicating-dial
19	GS42														2	Screw of indicating-dial
20	GW167-8														1	Feed regulating stud lock pin spring
21	GX179-8														1	Feed regulating stud lock pin
22	GR399-8														1	Feed regulating dial
23	GR738-8														1	Feed regulating dial
24	GR400-8														1	Feed regulating indicating-dial
25	GO214-8														1	Indicating dial washer
26	GO380-3														1	Feed regulating dial stud washer
27	GS249-8														1	Feed regulating dial stud
28	GS387-8														1	Feed regulating dial stud
29	GO204-8														1	Toothed nut
30	GS201-8														1	Screw of toothed nut

ACCESSORY

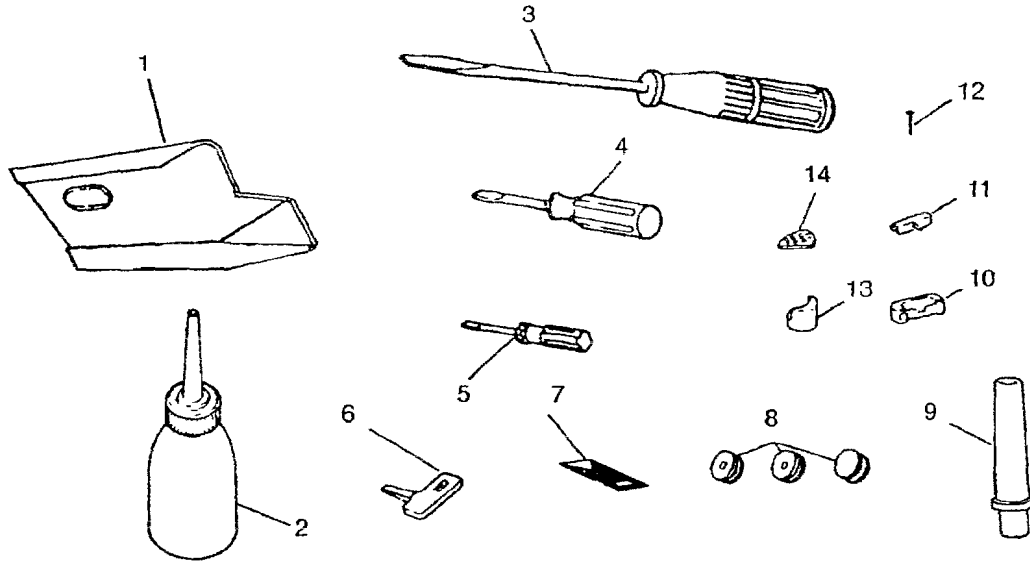

NO	PART NO.											QTY	DESCRIPTION			
		20U23	20U23D	20U33	20U43	20U53	20U53A	20U63	20U143	457A	457B			457D		
1	GR351-8	*	*	-	-	-	-	-	-	-	-	-	-	-	1	Oil reservoir
	GR413-8	-	-	*	-	*	*	-	-	-	-	-	-	-	1	Oil reservoir
	GR404-8	-	-	*	-	*	*	-	-	-	-	-	-	-	1	Oil reservoir
2	GF117-8	*	*	*	*	*	*	*	*	*	*	*	*	*	1	Oiler
3	GF114-8	*	*	*	*	*	*	*	*	*	*	*	*	*	1	Screwdriver(L)
4	GF115-8	*	*	*	*	*	*	*	*	*	*	*	*	*	1	Screwdriver(M)
5	GF116-8	*	*	*	*	*	*	*	*	*	*	*	*	*	1	Screwdriver(S)
6	GR788-8	-	-	-	-	-	-	-	-	-	-	-	-	-	1	T-type open knife
7	GV130-8	*	*	*	*	*	*	*	*	*	*	*	*	*	1	Needle
8	GN132-8	*	*	*	*	*	*	*	*	*	*	*	*	*	3	Bobbin
9	GBR211-8	*	*	*	*	*	*	*	*	*	*	*	*	*	1	Machine head pole
10	GR1593	*	*	*	*	*	*	*	*	*	*	*	*	*	1	Machine head hinge cushion rubber
11	GR696/2-8	*	*	*	*	*	*	*	*	*	*	*	*	*	1	Machine head hinge complete
12	GBX141-8	*	*	*	*	*	*	*	*	*	*	*	*	*	8	Oil reservoir nail
13	GBR204-8	*	*	*	*	*	*	*	*	*	*	*	*	*	2	Machine head cushion
14	GBR205-8	*	*	*	*	*	*	*	*	*	*	*	*	*	2	Machine head cushion

BELT COVER, THREAD-RUNNING COMPONENTS, BOBBIN WINDER, KNEE LIFTER ASSEMBLY

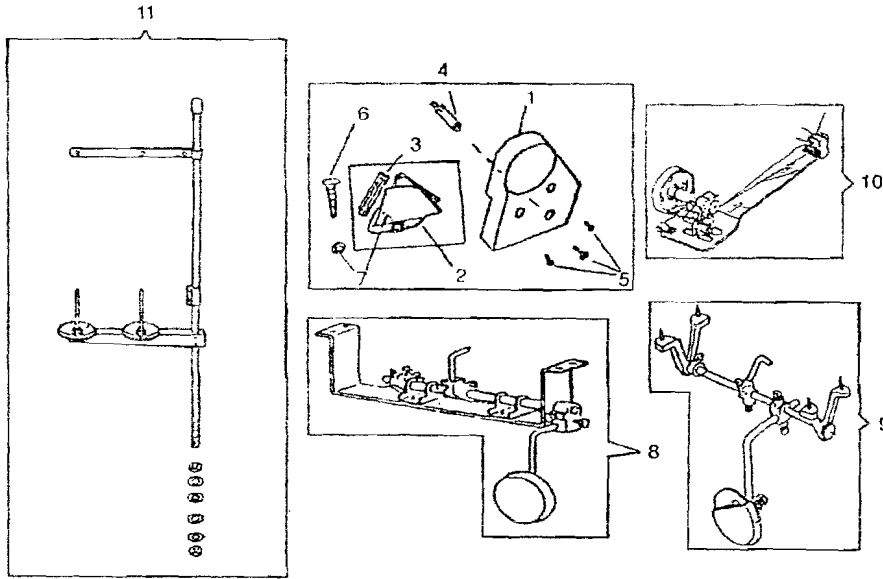

NO	PART NO.	20U23	20U23D	20U33	20U43	20U53	20U53A	20U63	20U143	457A	457B	457D	QTY	DESCRIPTION
1	GR526-8	-	-	*	*	*	*	*	*	*	*	*	1	Hand wheel cover
2	GK155-8	-	-	*	*	*	*	*	*	*	*	*	1	Hand wheel back cover
3	GK156-8	-	-	*	*	*	*	*	*	*	*	*	1	Hand wheel back cover cap
4	GS654-8	-	-	*	*	*	*	*	*	*	*	*	1	Back cover pole
5	GS360-8	-	-	*	*	*	*	*	*	*	*	*	3	Pole screw
6	GRS204-8	-	-	*	*	*	*	*	*	*	*	*	2	Back cover wood screw
7	GBR210-8	-	-	*	*	*	*	*	*	*	*	*	2	Wood screw washer
8	GR1315/18-8	-	-	*	*	*	*	*	*	*	*	*	1	Knee lifter complete
9	GR1110/18-8	-	-	*	*	*	*	*	*	*	*	*	1	Knee lifter complete
10	GR759/25-8	-	-	*	*	*	*	*	*	*	*	*	1	Thread-winding component
11	GR760-25-8	-	-	*	*	*	*	*	*	*	*	*	1	Thread stand

STANDBY PARTS

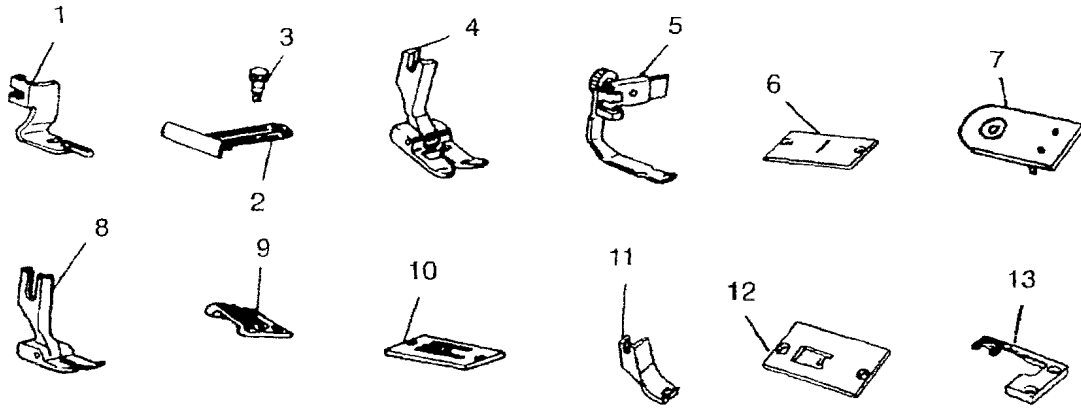

NO	PART NO											QTY	DESCRIPTION			
		20U23	20U23D	20U31	20U43	20U53	20U53A	20U63	20U143	457A	457B			457D		
1	FM108-8	-	-	-	-	-	-	-	-	-	-	-	-	-	1	Hemmer foot
2	FM105-8	-	-	-	-	-	-	-	-	-	-	-	-	-	1	Hemmer edge guide
3	GS655-8	-	-	-	-	-	-	-	-	-	-	-	-	-	1	Hwm edge guide screw
4	GM172-8	-	-	-	-	-	-	-	-	-	-	-	-	-	1	Buttonhole foot
5	FM109/3-8	-	-	-	-	-	-	-	-	-	-	-	-	-	1	Zipper foot complete
6	GM134-8	-	-	-	-	-	-	-	-	-	-	-	-	-	1	Emboidery plate
7	GM134/4-8	-	-	-	-	-	-	-	-	-	-	-	-	-	1	Emboidery plate
8	FM107/4-8	-	-	-	-	-	-	-	-	-	-	-	-	-	1	Straight stitch foot complete
9	FM106-8	-	-	-	-	-	-	-	-	-	-	-	-	-	1	Straight stitch feed dog
10	FM104-8	-	-	-	-	-	-	-	-	-	-	-	-	-	1	Straight stitch throat plate
11	FM103-8	-	-	-	-	-	-	-	-	-	-	-	-	-	1	Hem stem presser foot
12	FM100-8	-	-	-	-	-	-	-	-	-	-	-	-	-	1	Hem stem needle plate
13	FM101-8	-	-	-	-	-	-	-	-	-	-	-	-	-	1	Hem stem feed dog