

ARTISAN®

1988-MDZ

**Single Needle High Speed Dry Lubricated Lockstitcher With
Thread Trimmer**

**Instruction Manual
Parts Catalog**

Artisan Sewing Supplies, LLC. San Francisco, CA 94103

----- CONTENTS -----

1. PRECAUTIONS BEFORE STARTING OPERATION	1
1) Safety precautions	1
2) Precaution before Starting Operation	1
3) Precaution for Operating Conditions	1
2. PREPARETION BEFORE START TO OPERATE	2
Adjustment of needle bar stop position	2
3. PRECAUTIONS FOR STARTING TO OPERATE	2
1) Lubrication	2
2) Adjustment of the amount of oil for hook	3
3) Periodical cleaning	3
4) Precaution for position detector	4
5) Installing the belt cover	4
4. HOW TO USE THE MACHINE	4
1) How to attach needle	4
2) Threading	5
3) Adjusting of stitch length & reverse lever	5
4) Adjustment of the thread guide	6
5) Adjusting of pressure of presser foot	6
6) Adjusting the thread tension	6
7) Adjustment of upper thread tension	7
8) Adjustment of lower thread tension	7
9) Thread wiper (for machine equipped with thread wiper)	8
10) How to wind the lower thread on the bobbin	8
11) Adjustment of feed dog height and inclination	9
12) Adjustment of remaining needle thread length after thread trimming	9
13) Adjustment of feed timing	10
14) Adjustment of forward/backward stitch length	10
15) Adjustment of knife engagement	11
5. SPECIFICATIONS	12
6. PARTS CATALOG	13
A) Arm bed & Its accessories	13
B) Sewing mechanism	17
C) Feeding and feed lifting & Rotating hook shaft mechanism	13
D) Stitch regulator mechanism	23
E) Presser foot mechanism	27
F) Knife actuating mechanism	29
G) Touch back mechanism & Detector mechanism	33
H) Wiper mechanism	35
I) Oil lubrication mechanism	37
J) Accessories	39

1. PRECAUTIONS BEFORE STARTING OPERATION

1) Safety precautions

- (1) When turning the power on, keep your hands and fingers away from the area around/under the needle and the area around the pulley.
- (2) Power must be turned off when the machine is not used,.
- (3) The power must be turned off before tilting the machine head, installing or removing the “V” belt, adjusting the machine, or when replacing.
- (4) Avoid placing fingers, hairs bars etc. nears the pulley, “V” belt, bobbin winder pulley, or motor when the machine is operation. Injury could result.
- (5) Do not insert fingers into the thread take-up cover, under/round the needle, or pulley when the machine is in operation.
- (6) If a belt cover, finger guard, and/or eye guard are installed, do not operate the machine without these safety devices.

2) Precaution before Starting Operation

- (1) If the machine's oil pan has an oil sump, never operate the machine before filling it.
- (2) If the machine is lubricated by a drop oiler , never operate the machine before lubricating.
- (3) When a new sewing machine is first turned on, verify the rotational direction of the pulley with the power on.
(The pulley should rotate counterclockwise when viewed from the pulley.)
- (4) Verify the voltage and (single or three) phase with those given on the machine nameplate.

3) Precaution for Operating Conditions

- (1) Avoid using the machine at abnormally high temperature (35°C or higher) or low temperatures (5°C or lower). Otherwise, machine failure may result.
- (2) Avoid using the machine in dusty conditions.

2. PREPARATION BEFORE START TO OPERATE

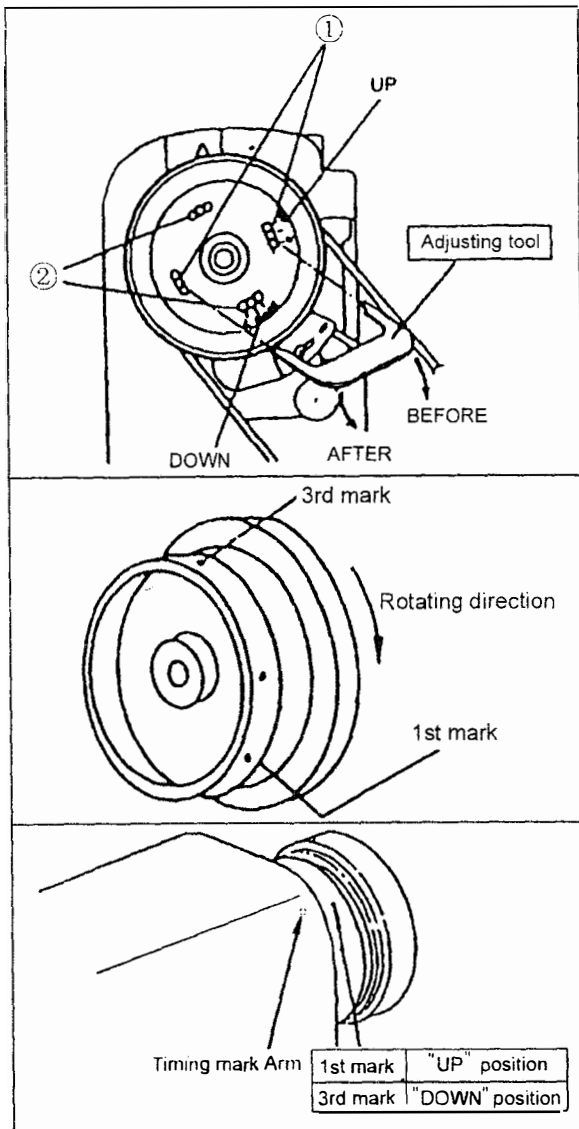

Adjustment of needle bar stop position

1) Adjust of "UP" position

When the pedal is kicked down by heel, the machine stops at "UP" position. If the marks deviate larger than 3mm adjust as follows.

- (1) Disconnect the plug (12 pins) of cable from the machine head.
- (2) Run the machine and stop at "UP" position.
- (3) While holding the pulley insert the "adjusting tool" in the hole ①, then remove the tool.

2) Adjust of "DOWN" position

When the pedal is Neutral the machine stops as "DOWN" position. If the marks deviate larger

- 1) Disconnect the plug (12 pins) of cable from than 3mm adjust as follows the machine head.
- 2) Run the machine and stop at "DOWN" position.
- 3) While holding the pulley insert the "adjusting tool" in the hole ②. then remove the tool.
- 3) Confirm the stop operation then the plug (12 pins) coming from the machine head into the receptacle.

3. PRECAUTIONS FOR STARTING TO OPERATE

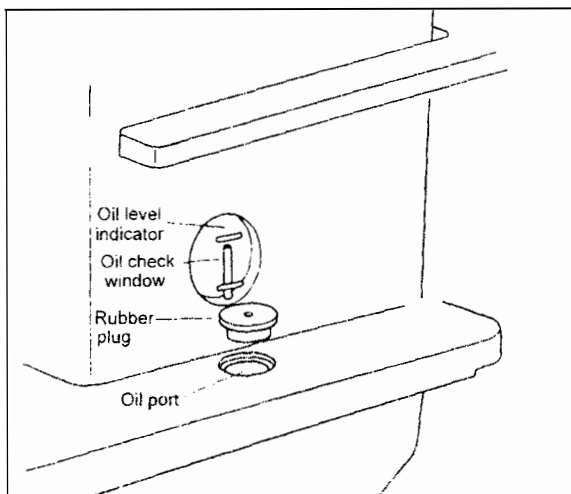

1) Lubrication

Before starting sewing machine operation, fill oil for hook lubrication into the oil tank.

- (1) Remove the rubber plug from the oil port, and fill the oil from the oil port.
- (2) Fill in oil until the tip of the oil level indicator matches the line in the oil check window.
- (3) When done filling the oil, set the rubber plug into the oil port.

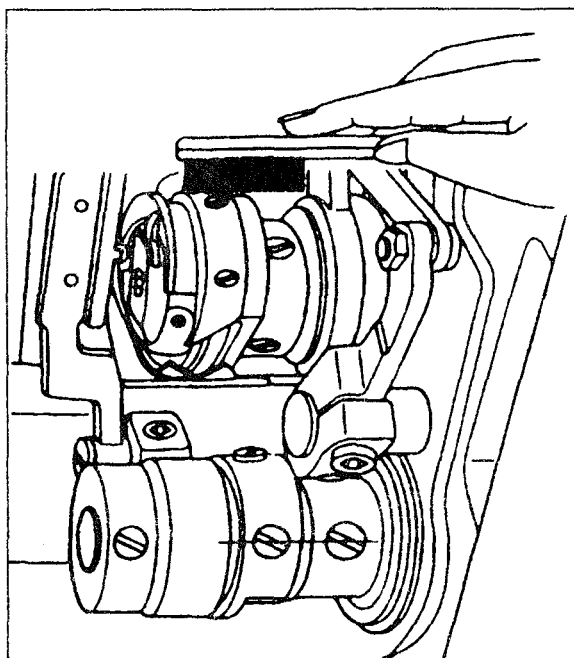
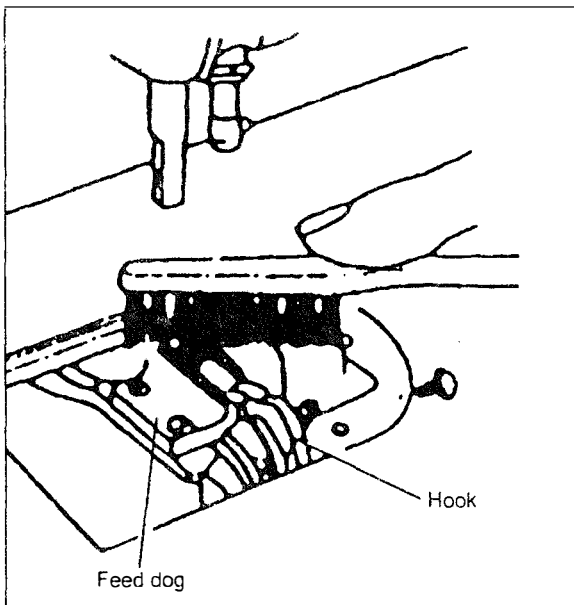
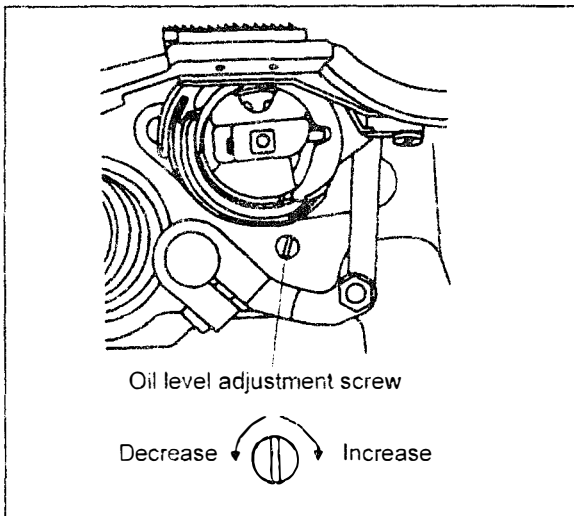

- (4) If the tip of the oil level indicator drops below the line in the oil check window during operation, replenish the oil.

2) Adjustment of the amount of oil for hook

turn the oil level adjustment screw, and adjust amount of oil for hook.

3) Periodical cleaning

a. Machine

- (1) Remove the throat plate and clean the feed dog.
- (2) Assembling is to be made by screwing in the screw by 2 to 3 rotations by hand at first, then tightening them evenly by use of a long size screw driver.

- (3) Lay down the machine head and clean the hook and inner bobbin case.

b. Maintenance of motor

Remove dust from the motor filter every one or two month. (If operation is continued with the filter clogged with lint or dust, the motor might overheat.)

c. Control box

Remove dust from the connector (If the connector covered with dust, machine might misoperated.)

4) Precaution for position detector

- (1) A light type detection element is used in the detector. Thus, take care not to adhere dust or oil on the detector plate sewing machine pulley is removed for adjustments, etc. If dust or oil does adhere, wipe off with a soft cloth while taking care not to scratch the detector plate. Do not allow oil to seep into the clearances of the detector plate.
- (2) If the position detector connector has been disconnected, the belt has been removed, or the machine has locked completely, the motor is automatically switched off in a predetermined period of time to prevent the motor from burning (The motor may not be switched off if incomplete lock-up or overload has occurred.) The operation is restored to normal by switching the power off, and then on after the fault has been repaired. The above also takes place when the detector has become faulty or any wire has been broken.

5) Installing the belt cover

- (1) machine side Install the belt cover for safety purposes. Refer to the instructions enclosed with the accessories.
- (2) motor side Install the belt cover for safety purposes.

4. HOW TO USE THE MACHINE

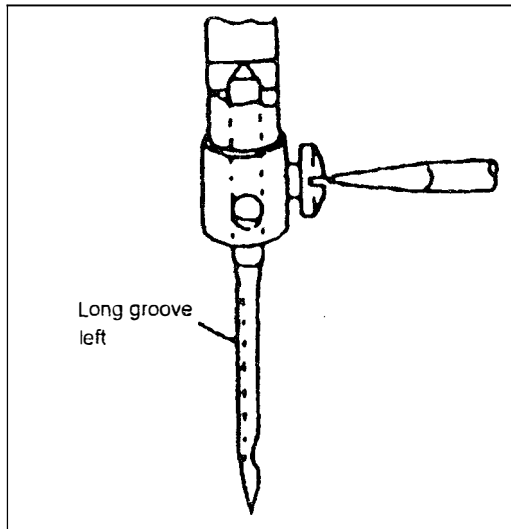

1) How to attach needle

Note: Before making the following adjustment, be sure to switch off the power source

Insert the needle up to the bottom of needle clamp and tighten the screw keeping the long groove side of needle forward the left.

Note: if snapping of thread occurs during back Sewing with polyester threads, it may be avoided by fitting the needle with the long groove Shifted to the front side.

Use DB×1 or DA×1 needle. According to fabric & thread ,please choose the size of needle as follows.

Size of Needle	No. of thread	Fabric
#9	#100 to #80	Extra thin fabric such as de Chin, Georgette, Organdy etc
#11	#80 to #60	Thin fabric such as Silk, Calico, Poplin. etc.
#14	#60 to #50	General fabrics such as Cotton, Wooden fabric ,etc.
#16	#50 to #30	Thick Cablico, Thick wooden fabric, Water proof cloth, thin leather, ect.
#18	#40 to #20	Thick fabric such as Suiting and Coat material, thin Pouches, Denim , ect.

2) Threading

Raise the thread take-up lever to its highest position and thread the upper thread in the following order.

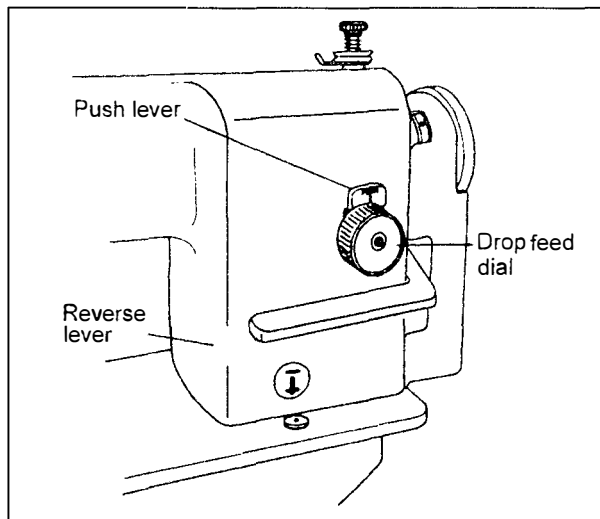
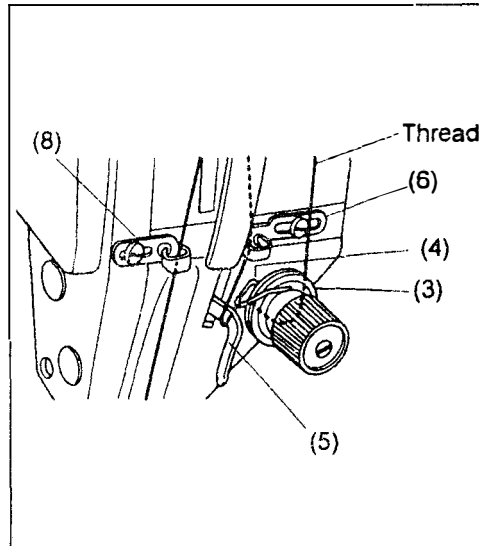
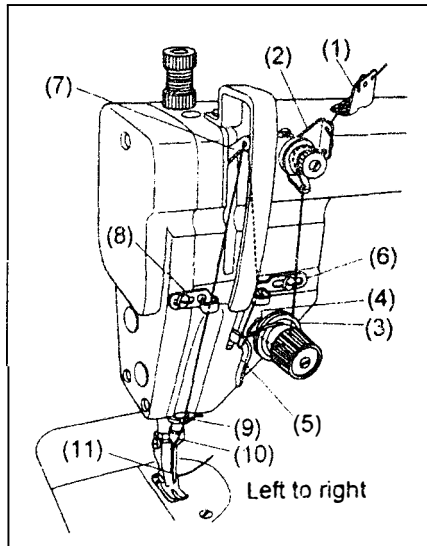

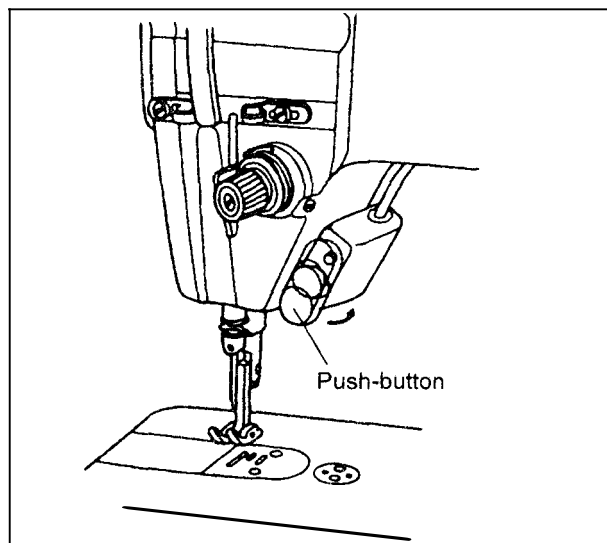

3) Adjusting of stitch length & reverse lever

- (1) Rotate the drop feed dial while depressing the reverse lever and then, pressing the push lever, when making the stitch length shorter.
- (2) If the reverse lever is depressed, reverse sewing (backward sewing) will take place.



- (3) Touchback switch
 - a. With the push-button (touchback switch) pressed lightly during sewing, reverse sewing can be done.
Reverse sewing will take place while the push-button is pressed.
When the push-button is released, reverse sewing turns into forward sewing.
 - b. When the push-button is turned 180 degrees in the direction of the arrow, the switch will be locked, and backward sewing will not take place even if the button is pressed.

4) Adjusting of the thread guide

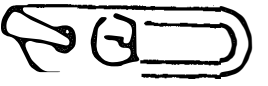
	1	2	3
Thread guide position	Left 	Middle 	Right 
Materials	Heavy	Medium	Light
Thread(Ref.)	Polyester Cotton Vinylon #30 or more	Polyester #50 to #60	Polyester #50 to #60
		Cotton Vinylon #50 to #80	

Refer to the table above, and adjust according to the stitching conditions, the material and thread

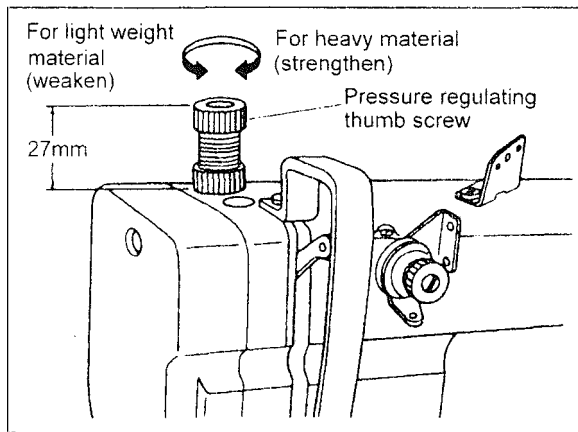

5) Adjusting of pressure of presser foot

Pressure of the presser foot can be adjusted by turning the pressure regulating thumb screw

6) Adjusting of thread tension

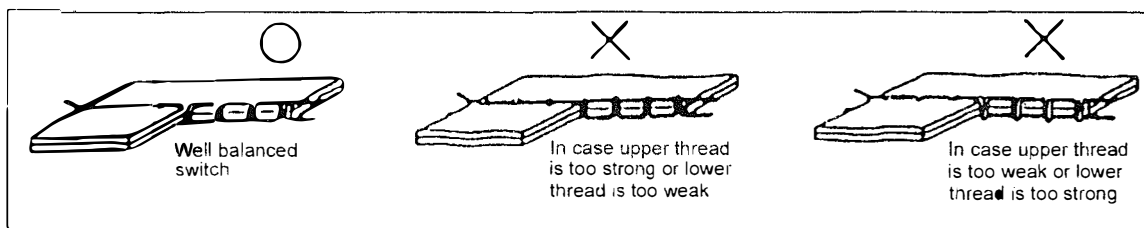

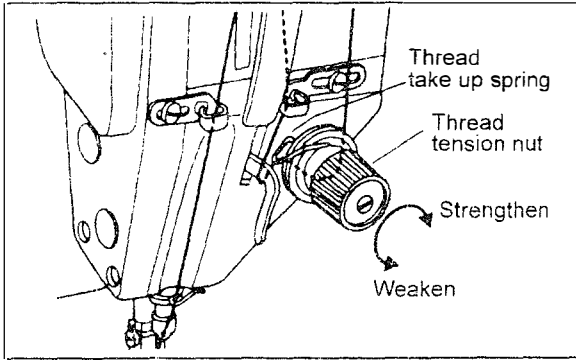

7) Adjusting of upper thread tension

- (1) Upper thread tension can be adjusted by thread tension nut.
- (2) Upper thread is to be adjusted according to the lower thread tension.
- (3) For special fabric sewing with special thread, the desired tension can be obtained by adjusting the strength and operating range of thread take-up spring.

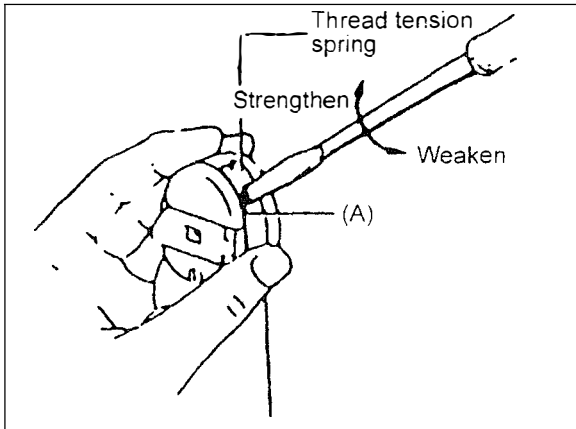

8) Adjusting of lower thread tension

- (1) Lower thread tension can be adjusted by screw (A).

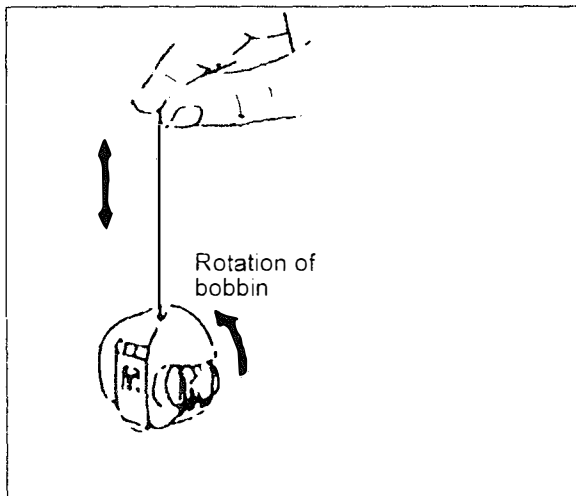

- (2) In the case of cotton thread #60, the thread tension can be checked as the following. Hold the end of pulled out thread and if the bobbin case fall slowly, the tension is proper.

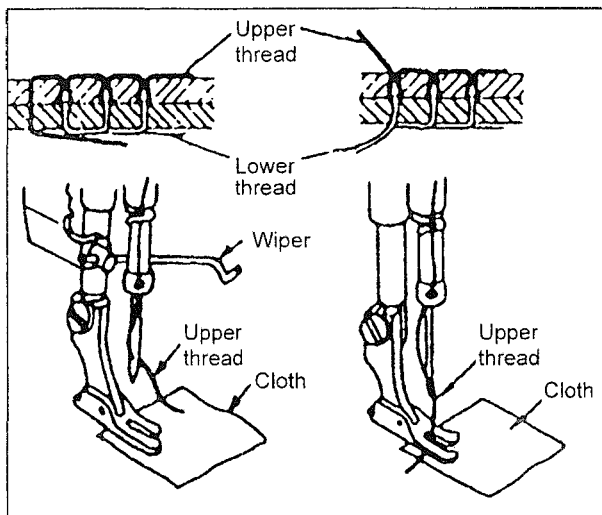

9) Thread wiper(for machine equipped with thread wiper)

- (1) When the thread wiper is operated, in next sewing at starting point the end of upper thread does not remain on the surface of fabric.
- (2) Turn the switch OFF when not required. The switch is located in the wiper solenoid cover behind the arm.

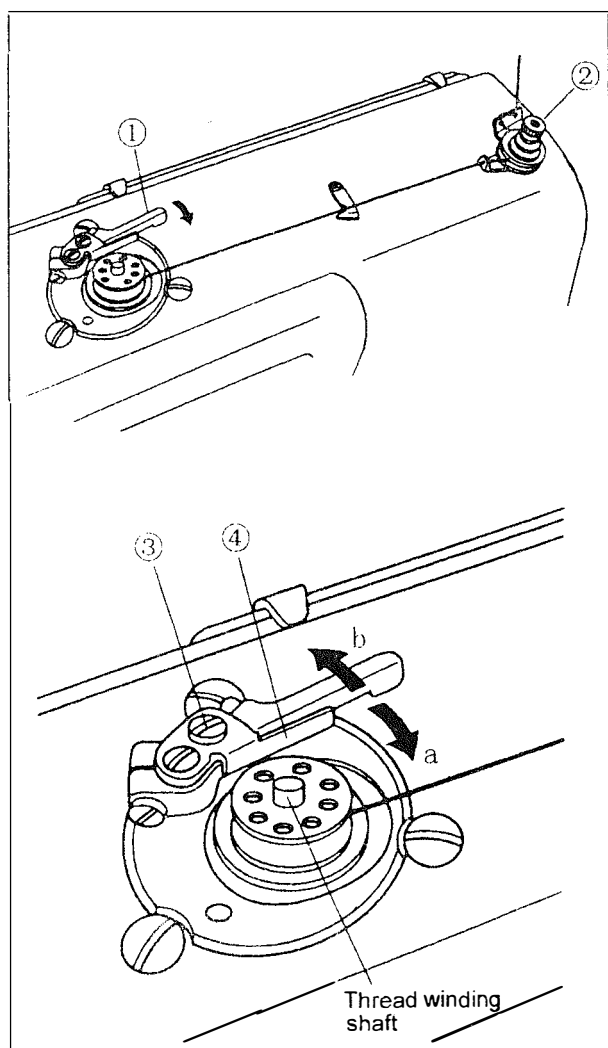

10) How to wind the lower thread on the bobbin

- (1) Press the bobbin onto the thread winding shaft.
- (2) Pass the thread for winding thread as shown in the figure, and wind the end of the thread clockwise around the bobbin several times, then wind the thread on the thread adjuster side counter-clock wise several times.
- (3) Press lever ① in the direction of the arrow, and start the sewing machine.
- (4) The operation will automatically stop when winding is completed.
- (5) Adjustment of thread winding strength
Adjust with the thread adjuster nut ②.
- (6) Adjustment of thread winding amount
Adjust by loosening screw ③ and moving the adjustment plate ④
 - a. The thread winding amount will decrease when moved in the direction of a.
 - b. The thread winding amount will increase when moved in the direction of b.

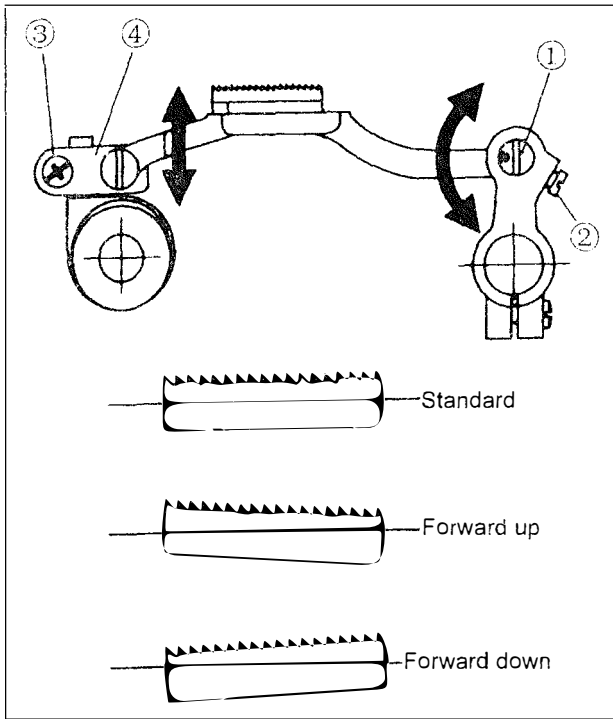

11) Adjustment of feed dog height and inclination

- (1) As a standard, the eccentric shaft ① mark on the left of the horizontal feed arm is set to the direct left side, and the feed dog height is set to 0.8mm (maximum) as shown in the figure.
- (2) To adjust the feed dog height and inclination, loosen the screw ② at the left of the horizontal feed arm, and turn the eccentric shaft ①, or loosen the screw ③ on joint ④, and move the joint ④ up and down.
- (3) When the eccentric shaft is set to 'DOWN' position, puckering may be avoided and free loop is less like to occur.
- (4) When the eccentric shaft is set to 'UP' position, misalignment of fabrics is less likely to occur and yarn severance may be avoided.

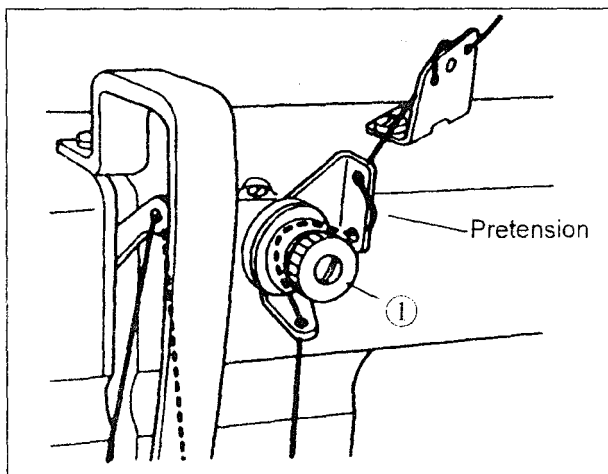

12) Adjustment of remaining needle thread length after thread trimming

- (1) Turn the pretension nut ① and adjust.
- (2) When turned clockwise, the length of thread left in the needle will be short.
When turned counterclockwise, the length of the thread left in the needle will be long.

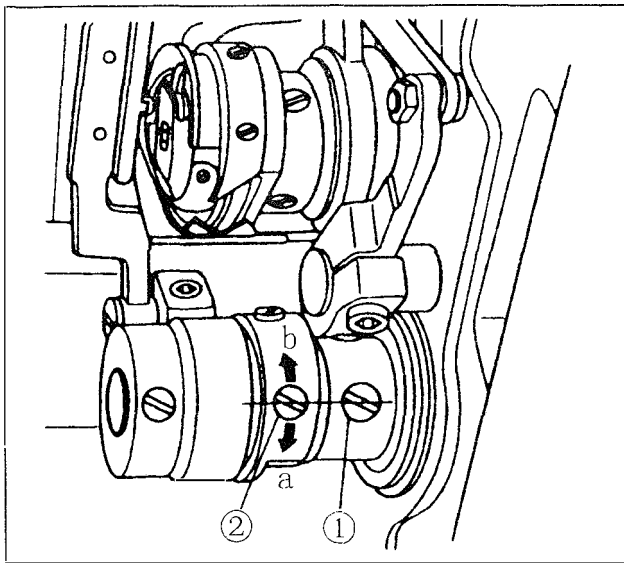

13) Adjustment of feed timing

- (1) Adjust by changing the position of the vertical feed eccentric ring.
- (2) As a standard, the vertical feed timing is set to when the screw ① on the bearing bushing is linear with screw ② on the vertical feed eccentric ring.
- (3) When the eccentric ring is moved in the direction of a, the vertical feed dog will rise earlier.
- (4) When the eccentric ring is moved in the direction of b, the vertical feed dog will rise later.

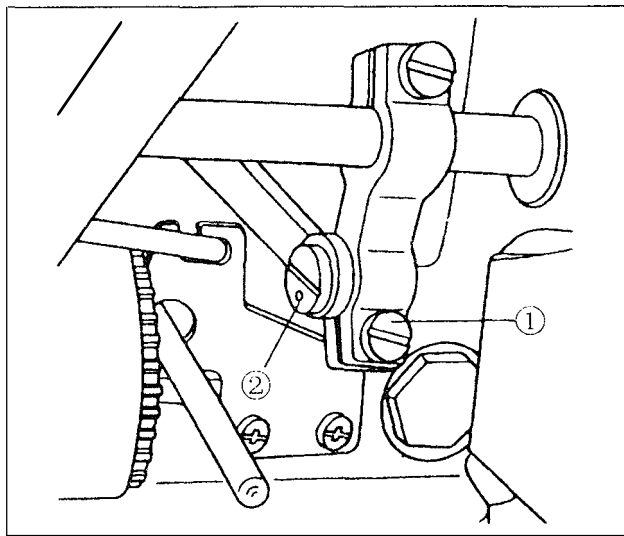

14) Adjustment of forward/backward stitch length

- (1) Loosen screw ① on the right of the adjustment arm.
- (2) Turn the eccentric shaft ② and adjust.
- (3) The forward stitch length will increase and the backward length will decrease when the eccentric shaft ② is turned counterclockwise.
- (4) The forward stitch length will decrease and the backward length will increase when the eccentric shaft ② is turned clockwise.

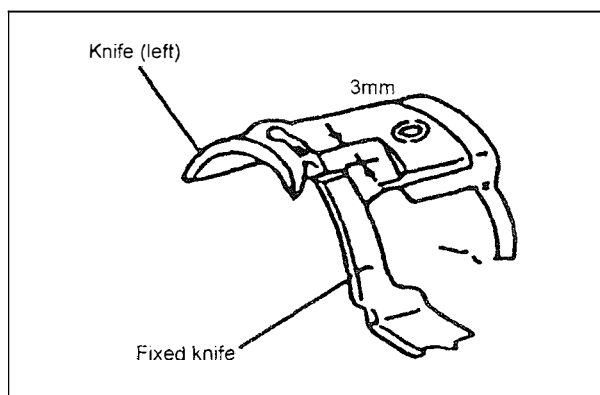
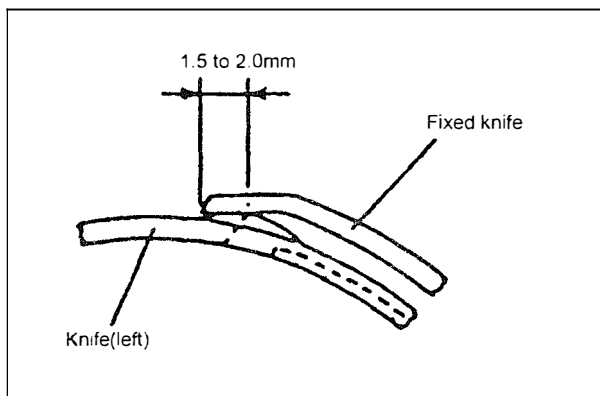
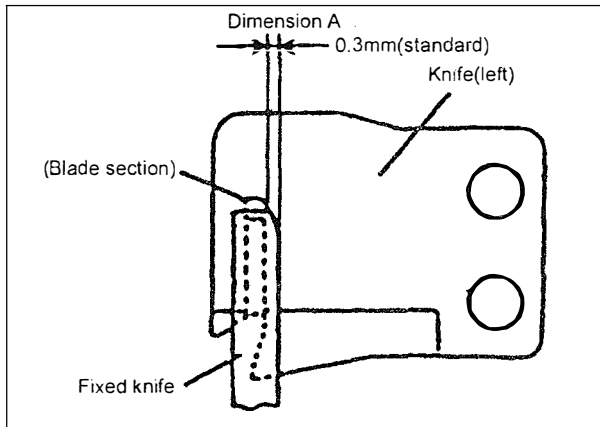
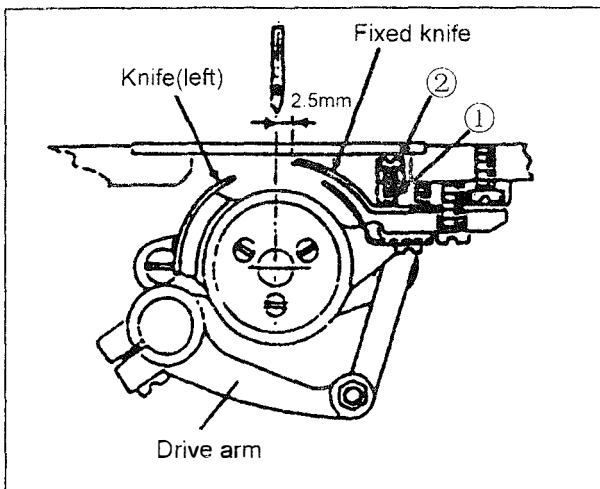

15) Adjustment of knife engagement

a. Position of fixed knife

- (1) As a standard, the dimension between the fixed knife's end and the needle center is 2.5mm.
- (2) The standard relation of the knife (left) and fixed knife is shown in the figure. As a standard, Dimension A is 0.3mm.
- (3) When Dimension A is too large, the three piece of threads will be cut, and can cause the needle thread to come out from needle after trimming. If too small, the thread may not be trimmed correctly.
- (4) Adjust by adjusting the installation of the fixed knife.

b. Knife engagement amount

- (1) When the sewing machine is rotated while the solenoid is activated, the knife (left) will be rotated by the thread trimming cam. As a standard, the knife engagement amount should be 1.5 to 2.0mm when the knife (left) moves the most.
- (2) Adjust by adjusting the installation of the drive arm.

c. Adjustment of knife engagement pressure

- (1) As a standard, the knife (left) and fixed knife should start contacting at the position shown in the figure.
- (2) To adjust the engagement pressure, loosen the lock nut ② and then adjust the adjustment screw ①.

5. SPECIFICATIONS

Material weight	Light to medium	
Max. speed	5,000rpm	
Stitch length	0 to 4mm	
Needle bar stroke	31.8mm	
Presser foot clearance	Hand Lifter	6 mm
	Knee lifter	13 mm
Needle type	DB×1 #14	
Hook (for thread trimming)	Full rotation automatic lubrication (standard)	
Bobbin case	With spring for dry run prevention	
Bobbin	Steel for thread trimmer	
Thread trimming method	Left knife rotating, right knife fixed engagement type	
Oil lubrication method	Automatic lubrication (slightly lubricate to hook and needle bar.)	
Bed dimensions	475×178 mm	

Note: Always use a hook and bobbin case dedicated for the thread trimmer use a high quality bobbin that will not deform.

A.ARM BED AND ITS ACCESSORIES

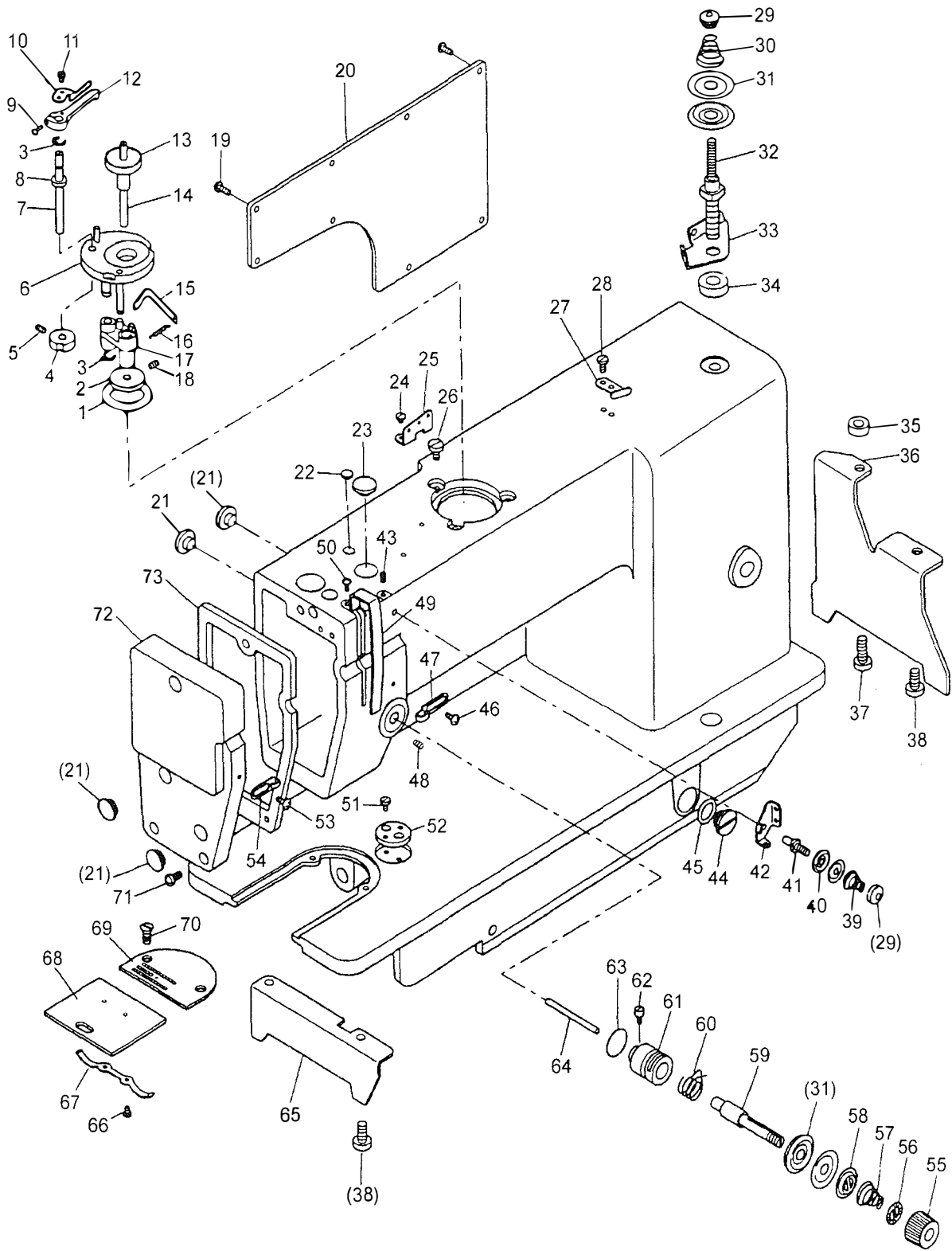

A.ARM BED AND ITS ACCESSORIES

Fig. No.	Part No.	Description	Pcs.	Remarks
A01	H6719N8001	Rubber ring	1	
A02	H6718N8001	Bobbin winder wheel	1	
A03	H007013050	E-type stop ring 5	2	
A04	H6725N8001	Bobbin winder cam	1	
A05	H431050060	Socket sets screw	1	M5×6
A06	HB2252N072	Bobbin winder base	1	
A07	H6723N8001	Cam shaft	1	
A08	H6722N8001	Spacer	1	
A09	HA100H2150	Screw 9/64(40)×11	1	SM9/64(40)×11
A10	H6721N8001	Adjust plate	1	
A11	H3200B2100	Screw 9/64(40)×6.5	1	SM9/64(40)×6.5
A12	H6720N8001	Lever	1	
A13	H6717N8001	Bobbin cushion	1	
A14	H6716N8001	Bobbin winder shaft	1	
A15	H6715N8001	Plate spring	1	
A16	H6724N8001	Spring	1	
A17	H6711N7101	Bobbin winder shaft holder assy	1	
A18	H431040060	Socket set screw M4×6	2	M4×6
A19	HA300B2170	Screw 11/64(40)×8	8	SM11/64(40)×8
A20	HB2261B081	Arm side cover	1	
A21	HA307B0674	Rubber plug Φ11.8	4	
A22	HA300B2090	Rubber plug Φ8.8	1	
A23	HA307B0673	Rubber plug Φ19	1	
A24	HA700B2060	Screw 11/64(40)×8	1	SM11/64(40)×8
A25	HA700B2050	Thread guide (arm top)	1	
A26	H3107G0662	Screw 11/64(40)×8	3	SM11/64(40)×8
A27	H6756B8001	Thread cutter	1	
A28	H6762B8001	Screw 9/64(40)×4.5	2	SM9/64(40)×4.5
A29	HA710B0671	Pre-tension adjusting nut 11/64(40)	2	SM11/64(40)
A30	H6739B8001	Thread tension spring Φ1.0	1	
A31	HA310B0705	Thread tension discs	4	
A32	H6735B8001	Thread tension stud	1	
A33	H6736B8001	Thread guide (arm top)	1	
A34	H6737B8001	Spacer	1	
A35	H6760B8001	Spacer	1	
A36	HB2262B081	Bed stud (right)	1	
A37	HA800F2020	Screw 15/64(28)×13.5	1	SM15/64(28)×13.5
A38	HA104F0654	Screw 15/64(28)×10	3	SM15/64(28)×10
A39	HA710B0672	Pre-tension spring	1	
A40	HA112B0693	Thread tension discs	2	
A41	HA710B0673	Thread tension stud	1	
A42	HA710B0674	Thread guide	1	
A43	HA100B2110	Set screw 11/64(40)×5.5	1	SM11/64(40)×5.5

A.ARM BED AND ITS ACCESSORIES

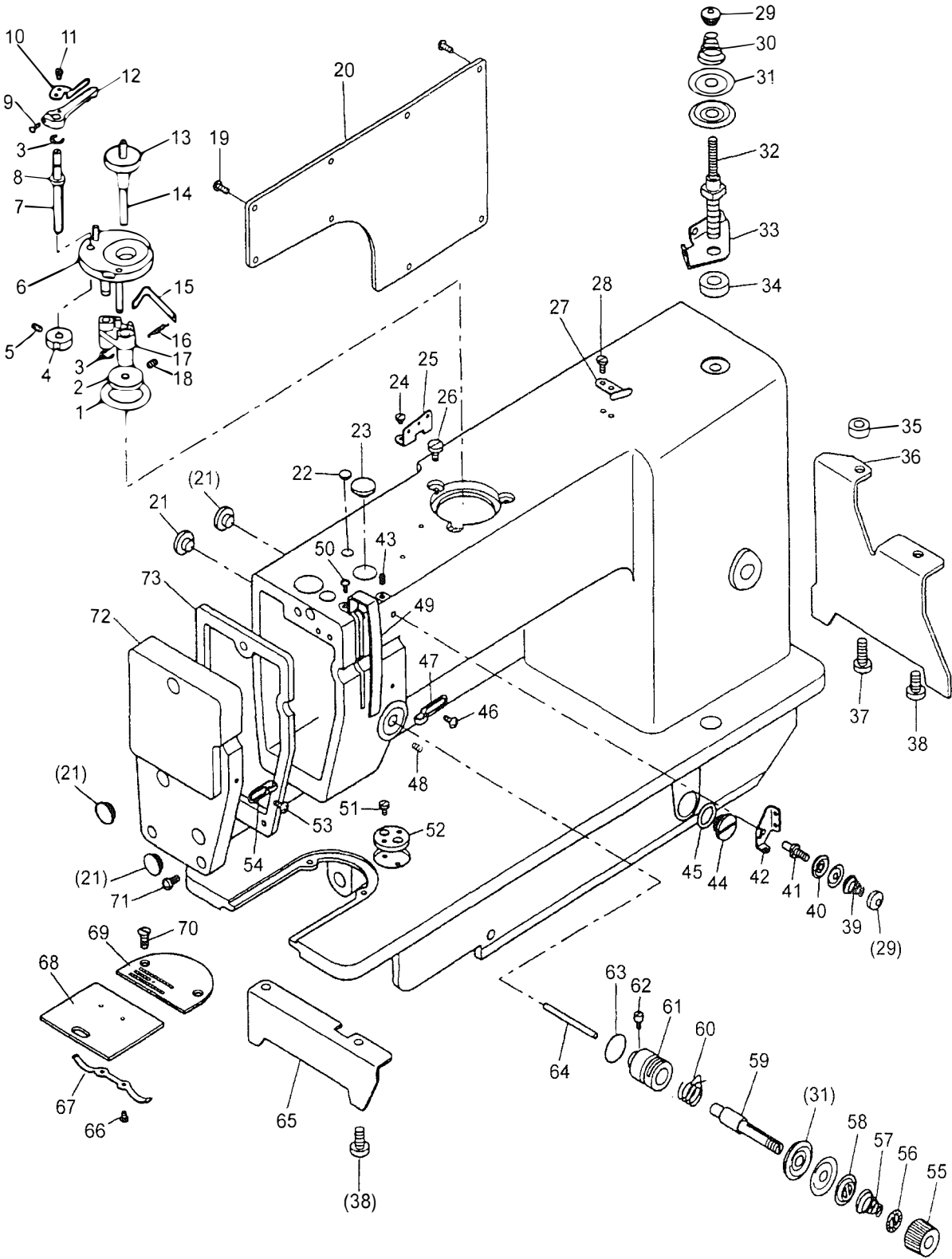

A.ARM BED AND ITS ACCESSORIES

Fig. No.	Part No.	Description	Pcs.	Remarks
A44	H6744B8001	Screw 1/2(24)×8	1	SM1/2(24)×8
A45	H6758B8001	O-ring	1	
A46	HA700B2110	Screw 9/64(40)×6	1	SM9/64(40)×6
A47	HA100B2140	Thread guide	1	
A48	HA300B2080	Set screw 15/64(28)×6	1	SM15/64(28)×6
A49	HB22511081	Thread take-up cover	1	
A50	HA707H0066	Screw 11/64(40)×8	1	SM11/64(40)×8
A51	HA300B2130	Screw 11/64(40)×5.5	2	SM11/64(40)×5.5
A52	HA300B2140	Plate for guide	1	
A53	HA106B0676	Screw 9/64(40)×6	1	SM9/64(40)×6
A54	HA106B0675	Thread guide	1	
A55	HA310B0701	Thumb nut	1	
A56	HA115B7010	Thumb net revolution stopper	1	
A57	HA115B0703	Thread tension spring Φ1.0	1	
A58	HA310B0702	Thread tension releasing discs	1	
A59	HA115B0701	Thread tension stud	1	
A60	HA115B0706	Thread take-up spring Φ0.6	1	
A61	HA310B0703	Thread tension regulator bushing	1	
A62	HA115B0708	Screw 9/64(40)×4	1	SM9/64(40)×4
A63	HA115B7011	O-ring	1	
A64	H6725B8001	Thread tension releasing pin Φ2×30	1	
A65	H6727B8001	Bed stud (left)	1	
A66	HA124B0713	Screw 3/32(56)×2.4	2	
A67	HA124B0712	Spring for slide plate	1	
A68	HA124B0711	Slide Plate	1	
A69	HA700B2100	Needle plate	1	
A70	HA300B2190	Screw 11/64(40)×8	2	SM11/64(40)×8
A71	HA300B2160	Screw 11/64(40)×10	3	SM11/64(40)×10
A72	HB2260B081	Face plate	1	
A73	H6722B8001	Casket for face plate	1	

B.SEWING MECHANISM

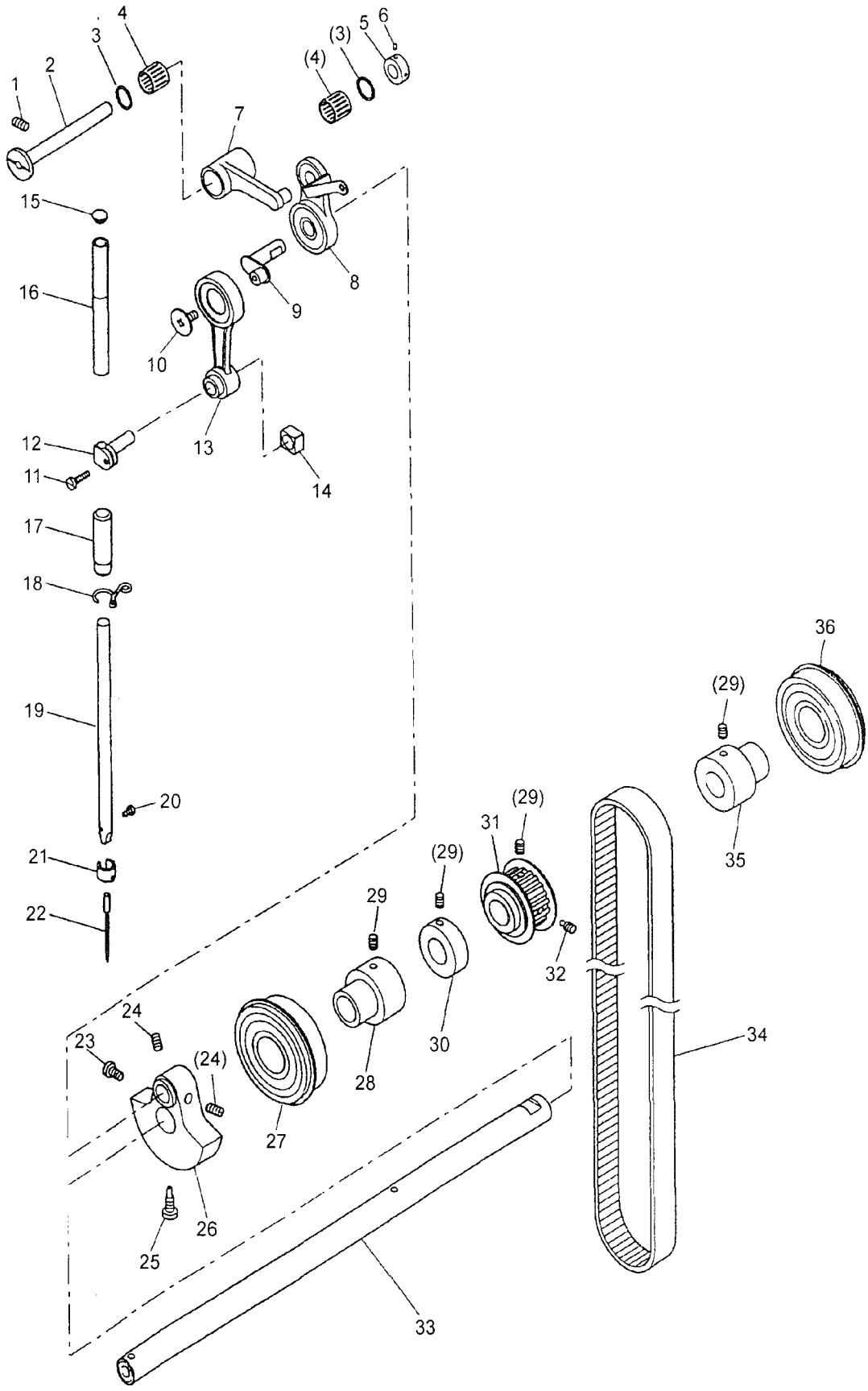

B.SEWING MECHANISM

Fig. No.	Part No.	Description	Pcs.	Remarks
B01	HA100C2020	Set screw 1 5/64(28)×10	1	SM15/64(28)×10
B02	H6716I8001	Thread take-up support shaft	1	
B03	H6718I8001	Bearing support	2	
B04	H6717I8001	Needle bearing	2	
B05	H6719I8001	Thrust collar	1	
B06	HA100B2110	Set screw 11/64(40)×5.5	2	SM11/64(40)×5.5
B07	H6710I8001	Thread take-up lever link	1	
B08	HB2254I072	Thread take-up lever	1	
B09	H6711I8001	Thread take-up crank	1	
B10	H6715I8001	Set screw (left-handed)	1	
B11	H2204C0651	Screw 9/64(40)×6.5	1	SM9/64(40)×6.5
B12	HA104C0658	Needle bar holder	1	
B13	HB2255I072	Needle bar link	1	
B14	H6704H8001	Square block	1	
B15	HA300B2090	Rubber plug Φ8.8	1	
B16	H6711B8001	Needle bar bushing (upper)	1	
B17	H6734B8001	Needle bar bushing (lower)	1	
B18	HA300C2070	Thread guide	1	
B19	HA705G0066	Needle bar	1	
B20	11A100C2170	Screw 1/8(44)×4.5	1	SM1/8(44)×4.5
B21	HA100C2150	Thread guide	1	
B22	HA100C2160	Needle DB×1-2-14	1	
B23	HA100C2060	Screw 9/32(28)×13	1	SM9/32(28)×13
B24	11A307C0662	Set screw 1/4(40)×5	2	SM1/4(40)×5
B25	HA100C2070	Screw 9/32(28)×14	1	SM9/32(28)×14
B26	116706C8001	Crank	1	
B27	113208I10661	Bail bearing	1	
B28	H6711C8001	Bushing	1	
B29	H431060080	Socket set screw M6×8	7	M6×8
B30	116713C8001	Bobbin winder driving wheel	1	
B31	116708C8001	Belt pulley(upper)	1	
B32	116715C8001	Screw M6	1	
B33	116704C8001	Upper shaft	1	
B34	116709C8001	Timing belt	1	
B35	116717C8001	Bushing	1	
B36	113205I0662	Ball bearing	1	

C.FEEDING AND FEED LIFTING & ROTATING HOOK SHAFT MECHANISM

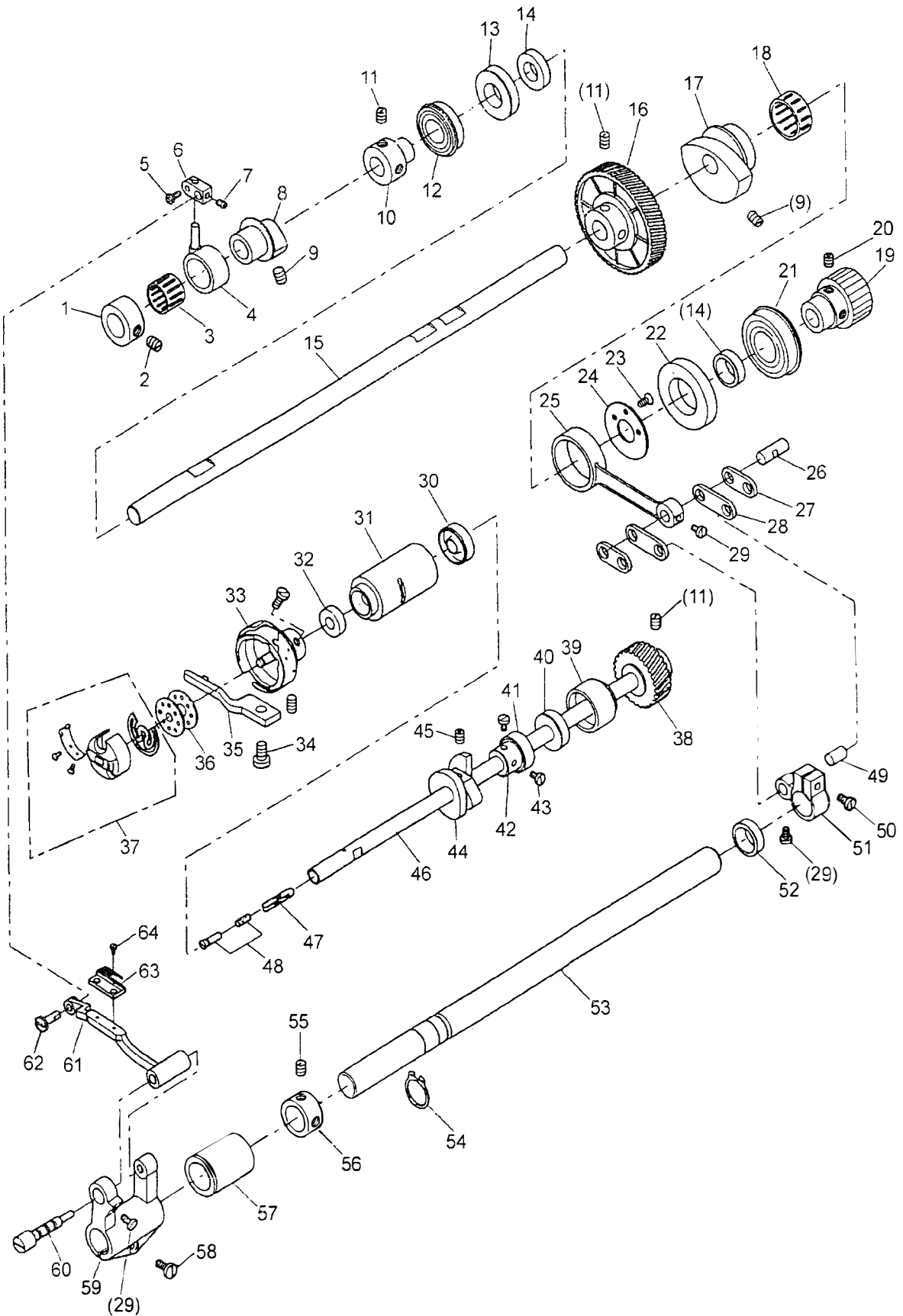

C.FEEDING AND FEED LIFTING & ROTATING HOOK SHAFT MECHANISM

Fig. No.	Part No.	Description	Pcs.	Remarks
C01	H6725D8001	Thrust collar	1	
C02	HA3411D308	Set screw 15/64(28)×7	2	SM15/64(28)×7
C03	H6720D8001	Needle bearing	1	
C04	H6722D8001	Feed lifting connecting rod	1	
C05	HA300B2160	Screw 11/64(40)×10	1	SM11/64(40)×10
C06	H6723D8001	Connecting block	1	
C07	H3205G1114	Socket set screw M5×5	1	M5×5
C08	H672ID8001	Feed lifting eccentric cam	1	
C09	HA100C2020	Set screw 15/64(28)×10	4	SM15/64(28)×10
C10	H6712D8001	Bushing	1	
C11	HA307C0662	Set screw 1/4(40)×5	6	SM1/4(40)×5
C12	H6711D8001	Ball bearing	1	
C13	H6714B8003	Bushing	1	
C14	H6745B8001	Oil seal	2	
C15	H6704D8001	Feed lifting rock shaft	1	
C16	H6708D7101	Gear(large)	1	
C17	H6705E8001	Level feed eccentric cam	1	
C18	H30211C206	Needle bearing	1	
C19	H6706D8001	Belt pulley(lower)	1	
C20	H6719C8001	Socket set screw M6×8	2	M6×8
C21	H3208H0661	Ball bearing	1	
C22	H6714B8001	Bushing	1	
C23	HA7311C306	Screw 3/16(28)×13	3	SM3/16(28)×13
C24	H30211C406	Thrust collar	1	
C25	H6706E8001	Level feed connecting rod	1	
C26	HA706C11B1	Link stud	1	
C27	H6724E8001	Link	2	
C28	H6709E8001	Link	2	
C29	HA7311C806	Screw 11/64(40)×7	3	SM11/64(40)×7
C30	H6709F8001	Oil seal	1	
C31	H6716B8001	Lower shaft bushing (left)	1	
C32	H6747B8001	Oil seal	1	
C33	HA707E0067	Rotary hook assy	1	
C34	HA100E2150	Screw 11/64(40)×10	1	SM11/64(40)×10
C35	HA300E2050	Rotary hook positioner	1	
C36	HA700E2060	Bobbin	1	
C37	HA708E0068	Bobbin case assy	1	
C38	H6709D8001	Gear(small)	1	
C39	H6715B8001	Lower shaft bushing (right)	1	
C40	H6747B8001	Oil seal	1	
C41	H6707F8001	Ball bearing	1	
C42	H6708F8001	Bushing	1	
C43	HA300B2130	Screw 11/64(40)×5.5	2	SM11/64(40)×5.5

C.FEEDING AND FEED LIFTING & ROTATING HOOK SHAFT MECHANISM

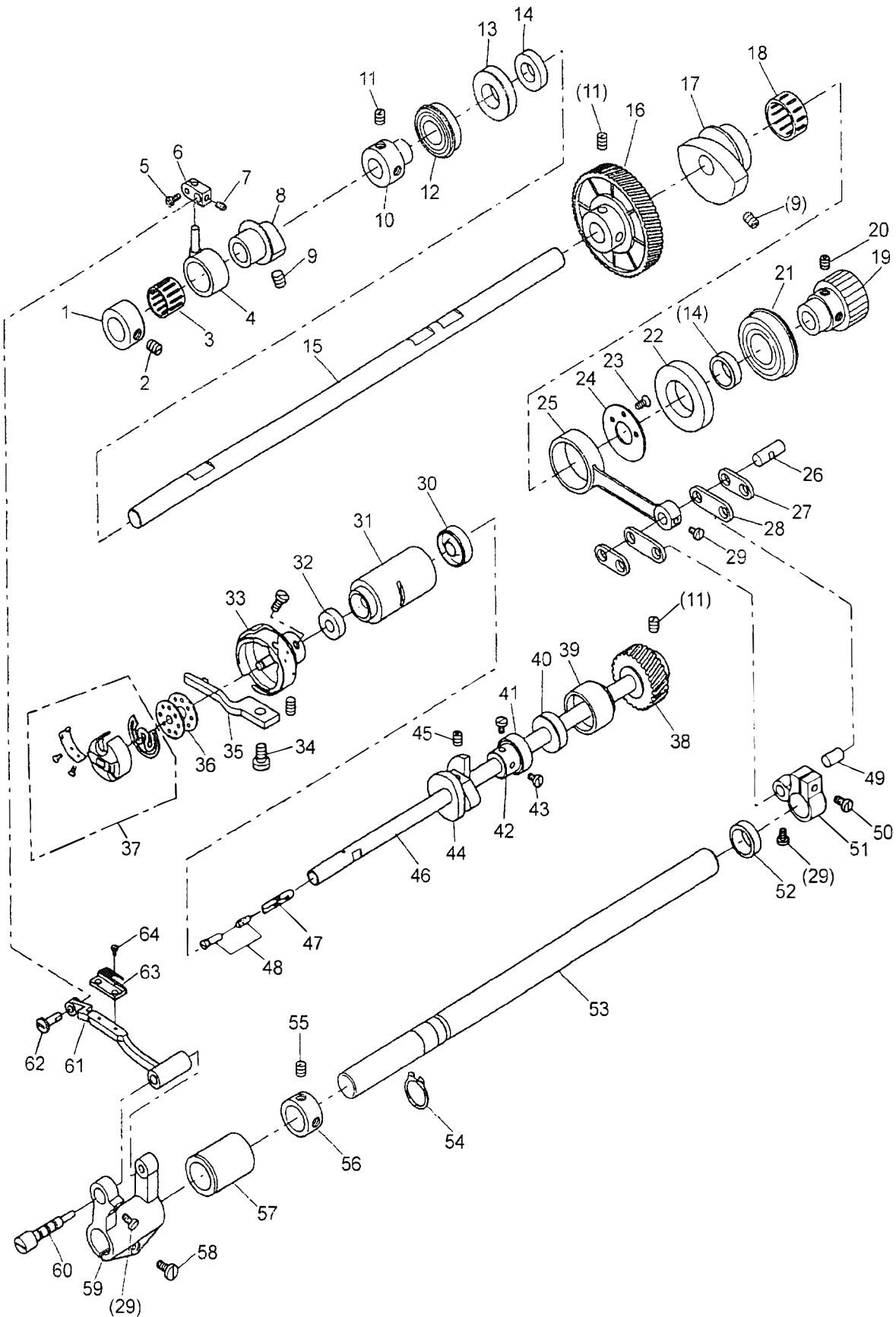

C.FEEDING AND FEED LIFTING & ROTATING HOOK SHAFT MECHANISM

Fig. No.	Part No.	Description	Pcs.	Remarks
C44	HA710E0691	Thread trimmer cam	1	
C45	HA710E0692	Socket set screw 1/4(40)×10	2	SM1/4(40)×10
C46	H6705F8001	Lower shaft	1	
C47	HA706C11B2	Oil wick	1	
C48	HA104E0011	Screw complete	1	
C49	HA706C11B2	Feed rock shaft crank pin	1	
C50	HA7311C606	Screw 11/64(40)×5	1	SM11/64(40)×5
C51	H6707E8001	Feed rock shaft crank (right)	1	
C52	H6748B8001	Oil seal	1	
C53	H6714E8001	Feed rock shaft	1	
C54	H007009150	Retaining ring-C type 15	1	
C55	HA105D0662	Set screw 1/4(40)×4	2	SM1/4(40)×4
C56	HA108G0661	Thrust collar	1	
C57	H6717B8001	Bushing for feed rock shaft (left)	1	
C58	HA104G0012	Screw 3/16(28)×12	1	SM3/16(28)×12
C59	H6715E8001	Feed rock shaft crank (left)	1	
C60	H6717E8001	Shaft for feed bar (eccentric)	1	
C61	H6716E8001	Feed bar	1	
C62	H6724D8001	Pin	1	
C63	HA104G0653	Feed dog	1	
C64	HA104G0654	Screw 1/8(44)×6	2	SM1/8(44)×6

D.STITCH REGULATOR MECHANISM

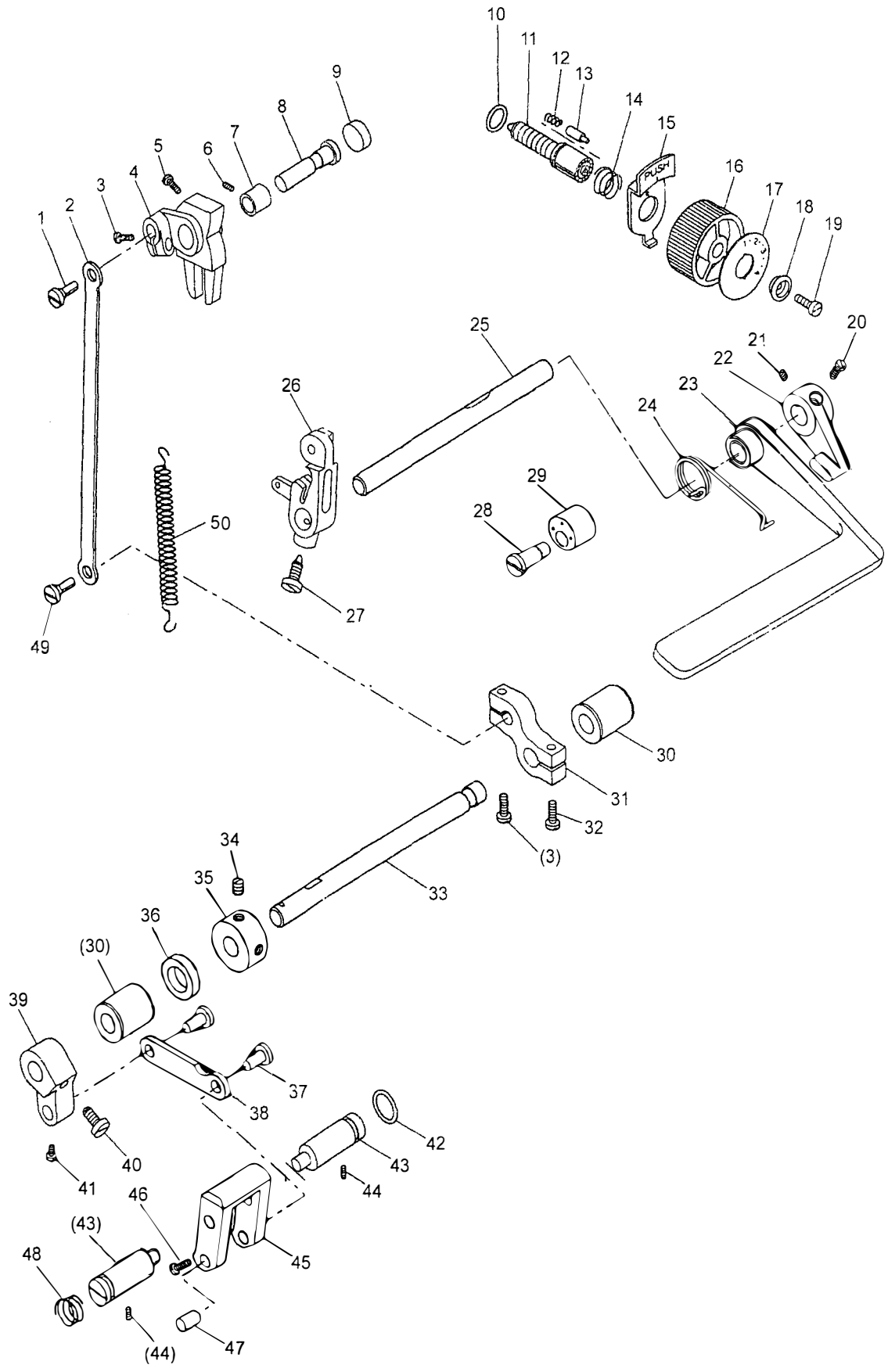

D.STITCH REGULATOR MECHANISM

Fig. No.	Part No.	Description	Pcs.	Remarks
D01	HA700C2060	Connecting rod stud	1	
D02	HB2253G081	Feed regulating link	1	
D03	HA111G0683	Screw 11/64(40)×12	2	SM11/64(40)×12
D04	HB2252G081	Feed regulator	1	
D05	HA113F0684	Screw 15/64(28)×8.5	1	SM15/64(28)×8.5
D06	HA100C2020	Set screw 15/64(28)×10	1	SM15/64(28)×10
D07	H6713B8001	Bushing for feed regulator	1	
D08	H6716G8001	Set pin	1	
D09	HA700B2120	Rubber plug Φ20	1	
D10	HA109F0674	O-ring	1	
D11	HA720F0681	Screw bar	1	
D12	HA100F2090	Spring	1	
D13	HA700F2030	Stopper pin	1	
D14	HA720F0687	Coil spring	1	
D15	HA720F0683	Releasing lever	1	
D16	HA7421F120	Dial for stitch length regulator	1	
D17	HA720F0684	Stitch length indicating plate	1	
D18	HA720F0685	Bushing	1	
D19	HA720F0686	Screw 3/16(28)×12	1	SM3/16(28)×12
D20	HA3411D308	Screw 15/64(28)×7	1	SM15/64(28)×7
D21	HA113F0684	Screw 15/64(28)×8.5	1	SM15/64(28)×8.5
D22	H49361.8001	Lever	1	
D23	HB2258G081	Reverse lever	1	
D24	H49391.8001	Spring	1	
D25	HB2260G081	Reverse lever shaft	1	
D26	HB2262G081	Reverse crank	1	
D27	H32001.2020	Screw 15/64(28)×12	1	SM15/64(28)×12
D28	H49371.8001	Screw 15/64(28)×6	1	SM15/64(28)×6
D29	H49381.8001	Rubber ring Φ16	1	
D30	H6718B8001	Bushing for feed regulating shaft	2	
D31	HB2256G081	Feed regulating crank (right)	1	
D32	HA8001.2020	Screw 15/64(28)×13.5	1	SM15/64(28)×13.5
D33	H6708G8001	Feed regulating shaft	1	
D34	HA307C0662	Set screw 11/64(40)×7	2	SM11/64(40)×7
D35	H6712G8001	Thrust collar	1	
D36	H6749B8001	Oil seal	1	
D37	H6710F8001	Connecting stud	2	
D38	H6711F8001	Link	1	
D39	H6712F8001	Feed regulating crank (left)	1	
D40	HA100F2130	Screw 15/64(28)×14.5	1	SM15/64(28)×14.5
D41	HA7311C806	Screw 11/64(40)×7	1	SM11/64(40)×7
D42	H6721F8001	O-ring	1	
D43	H6713F8001	Feed regulator shaft	2	

D.STITCH REGULATOR MECHANISM

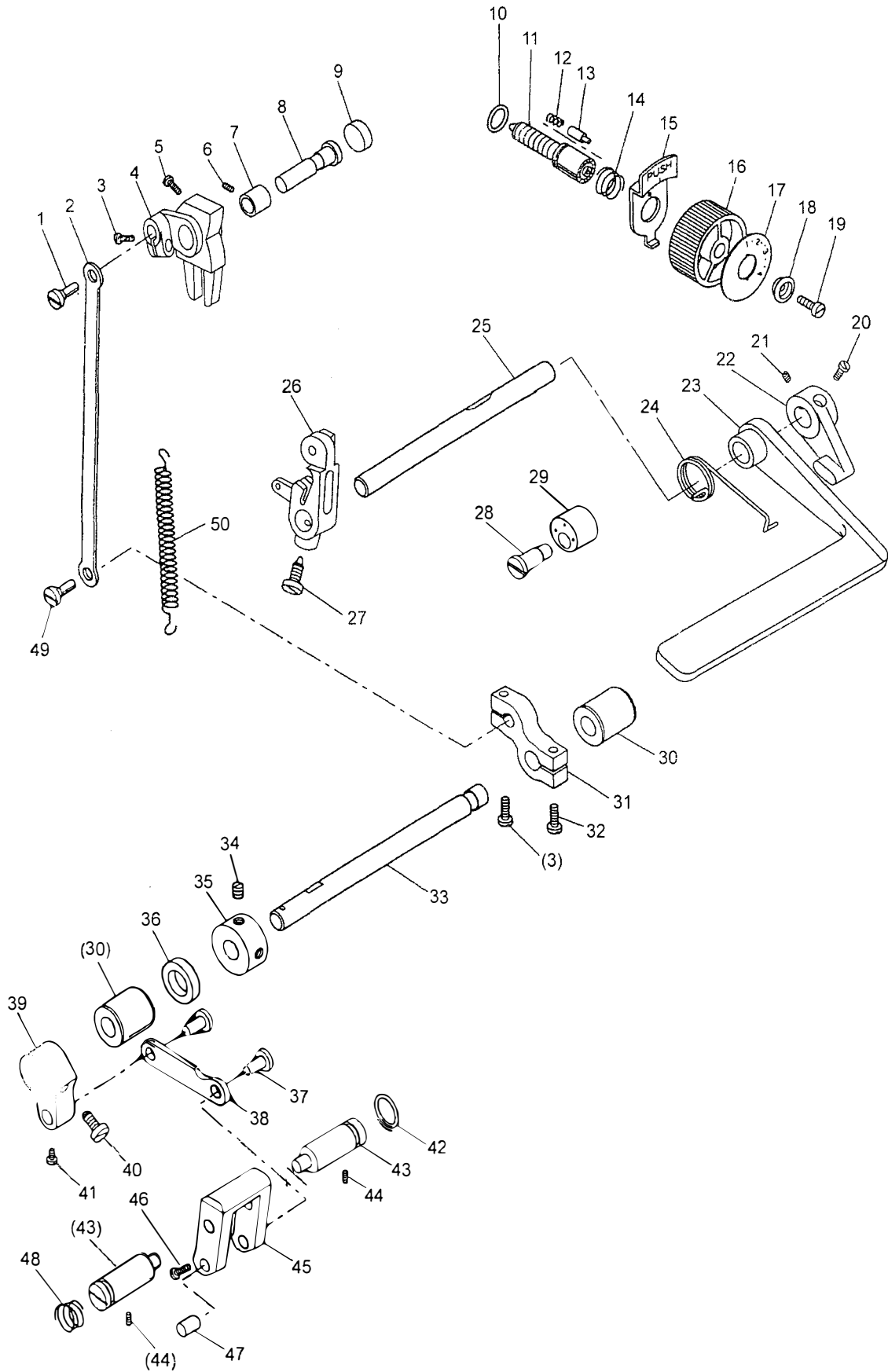

D.STITCH REGULATOR MECHANISM

Fig. No.	Part No.	Description	Pcs.	Remarks
D44	H3230K0751	Set screw 11/64(40)×10	2	SM11/64(40)×10
D45	H6708E8001	Stitch length adjusting crank	1	
D46	HA7311CD06	Screw 9/64(40)×8.5	2	SM9/64(40)×8.5
D47	HA7311CE06	Link stud	1	
D48	H6723E8001	Spring	1	
D49	H6707G8001	Eccentric shaft	1	
D50	H6713G8001	Coil spring	1	

E.PRESSER FOOT MECHANISM

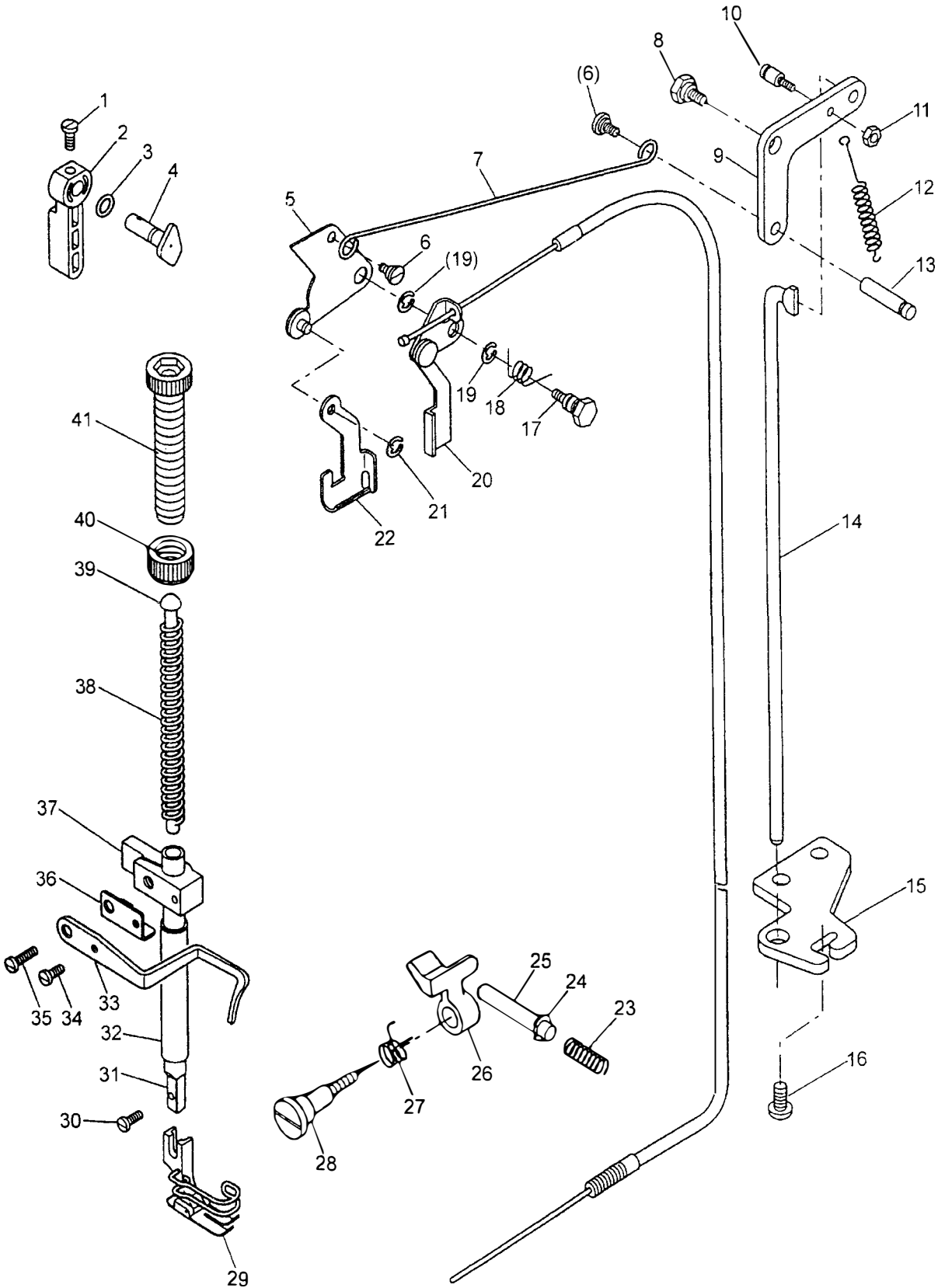

E.PRESSER FOOT MECHANISM

Fig. No.	Part No.	Description	Pcs.	Remarks	
E01	HA300B2170	Screw 11/64(40)×8.2	1	SM11/64(40)×8.2	
E02	H1204F0651	Presser bar lifter lever	1		
E03	HA300H2080	O-ring	1		
E04	H6728J8001	Presser bar lifter cam	1		
E05	H6708J7101	Knee lifter lever (left)	1		
E06	HA107H0662	Hinged screw 3/16(28)×7	2		SM3/16(28)×7
E07	H6712J8001	Knee lifter rod	1		
E08	HA100H2050	Stud bolt	1		
E09	H6720J8001	Knee lifter lever (right)	1		
E10	H6721J8001	Screw 3/16(28)×6.5	1		SM3/16(28)×6.5
E11	HA706N0663	Nut	1		
E12	H6722J8001	Spring for knee lifter lever	1		
E13	HA100H2080	Pin	1		
E14	H6723J8001	Knee lifter connecting rod	1		
E15	H6724J8001	Knee lifter connecting rod guide	1		
E16	HA300C2030	Screw 11/64(40)×8	2	SM11/64(40)×8	
E17	H6717J8001	Stud bolt	1		
E18	H6729J8001	Spring	1		
E19	H007013060	E-type stop ring 6	2		
E20	H6713J7101	Tension release lever assy	1		
E21	H007013040	E-type stop ring 4	1		
E22	H6711J8001	Pullup plate	1		
E23	H6732J8001	Tension release pin spring	1		
E24	H007013030	E-type stop ring 3	1		
E25	H6727J8001	Tension release pin	1		
E26	H6725J8001	Tension releaser	1		
E27	H6730J8001	Spring	1		
E28	H6726J8001	Stud screw	1		
E29	HA316H0070	Presser foot	1		
E30	HA100H2150	Screw 9/64(40)×11	1	SM9/64(40)×11	
E31	H6704J8001	Presser bar	1		
E32	H6712B8001	Bushing for presser bar	1		
E33	H6707J8001	Upper thread guide	1		
E34	H2000H2050	Screw 9/64(40)×8	1	SM9/64(40)×8	
E35	HA7311C606	Screw 11/64(40)×15	1		SM11/64(40)×15
E36	H6706J8001	Bracket plate	1		
E37	H6705J8001	Presser bar guide bracket	1		
E38	HA500H2010	Presser spring	1		
E39	H6733J8001	Spring guide	1		
E40	HA117H0692	Nut	1		
E41	HA309H0681	Thumb screw 1/2(28)	1		

F.KNIFE ACTUATING MECHANISM

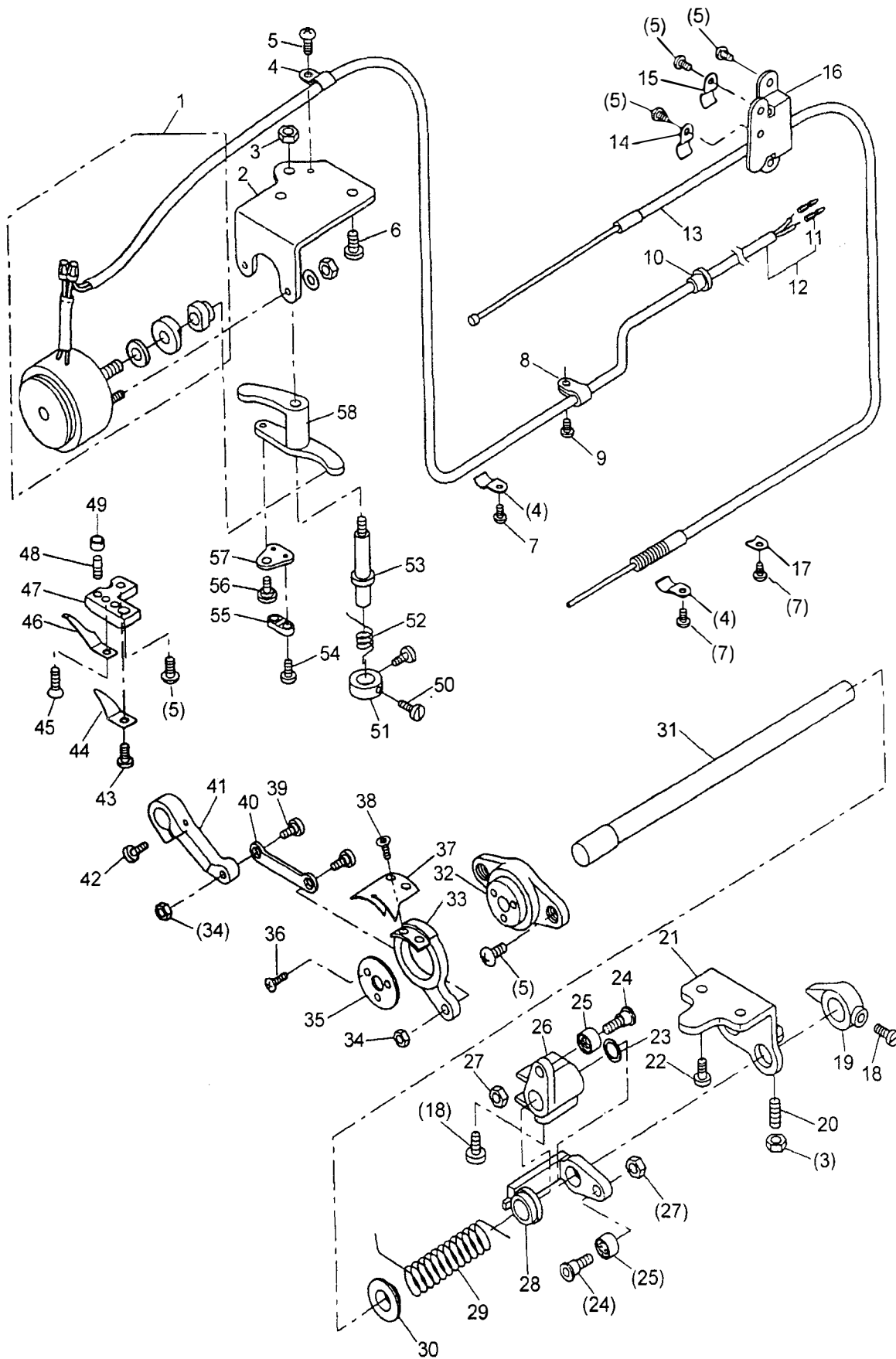

F.KNIFE ACTUATING MECHANISM

Fig. No.	Part No.	Description	Pcs.	Remarks
F01	H6717K7101	Thread trimming solenoid assy	1	
F02	H6715K8001	Solenoid bracket	1	
F03	HA710N0683	Nut	2	
F04	H6732K8001	Holder	3	
F05	HA300C2030	Screw 11/64(40)×8	8	SM11/64(40)×8
F06	HA700N0080	Screw 15/64(28)×12	2	SM15/64(28)×12
F07	H2000O0360	Screw 11/64(40)×6.2	3	SM11/64(40)×6.2
F08	H6727N8001	Cord holder	1	
F09	HA300B2170	Screw 11/64(40)×8.2	1	SM11/64(40)×8.2
F10	HA704O0657	Rubber plug Φ10	1	
F11	HA7641B319	Terminal pin	2	
F12	H6727K8001	Cord assy	1	
F13	H6730K8001	Flexible wire	1	
F14	H6729K8001	Holder	1	
F15	H32311D606	Holder	1	
F16	H6731K8001	Wire holder bracket	1	
F17	H6733K8001	Washer	1	
F18	HA113F0684	Screw 15/64(28)×8.5	3	SM15/64(28)×8.5
F19	H6713K8001	Stopper lever	1	
F20	H6735K8001	Set screw 15/64(28)×16	1	SM15/64(28)×16
F21	H6711K8001	Bracket	1	
F22	H6736K8001	Screw 15/64(28)×13	2	SM15/64(28)×13
F23	HA706N0664	Rubber washer	1	
F24	HA7221N206	Roller stud	2	
F25	HA7221N106	Roller	2	
F26	HA7211N106	Cam follower crank (1)	1	
F27	HA706N0663	Nut 3/16(28)	2	SM3/16(28)
F28	HA7211N206	Cam follower crank (2)	1	
F29	H6737K8001	Spring	1	
F30	HA700N0050	Bushing	1	
F31	H6710K8001	Knife driving shaft	1	
F32	H6707K8001	Knife holding bracket saddle	1	
F33	H6708K8001	Knife base (left)	1	
F34	HA7111N304	Nut 11/64(40)	2	SM11/64(40)
F35	H6738K8001	Thrust collar Φ28	1	
F36	H6739K8001	Screw 1/8(44)×6	3	SM1/8(44)×6
F37	HA7111N804	Movable knife (left)	1	
F38	HA7111N704	Screw 11/64(40)×7	2	SM11/64(40)×7
F39	HA7111N204	Stud screw 11/64(40)×6.2	2	SM11/64(40)×6.2
F40	HA7111N404	Link	1	
F41	H6709K8001	Knife driving crank	1	
F42	HA716F0662	Screw 11/64(40)×16	1	SM11/64(40)×16
F43	HA7311CH06	Screw 9/64(40)×8	1	SM9/64(40)×8

F.KNIFE ACTUATING MECHANISM

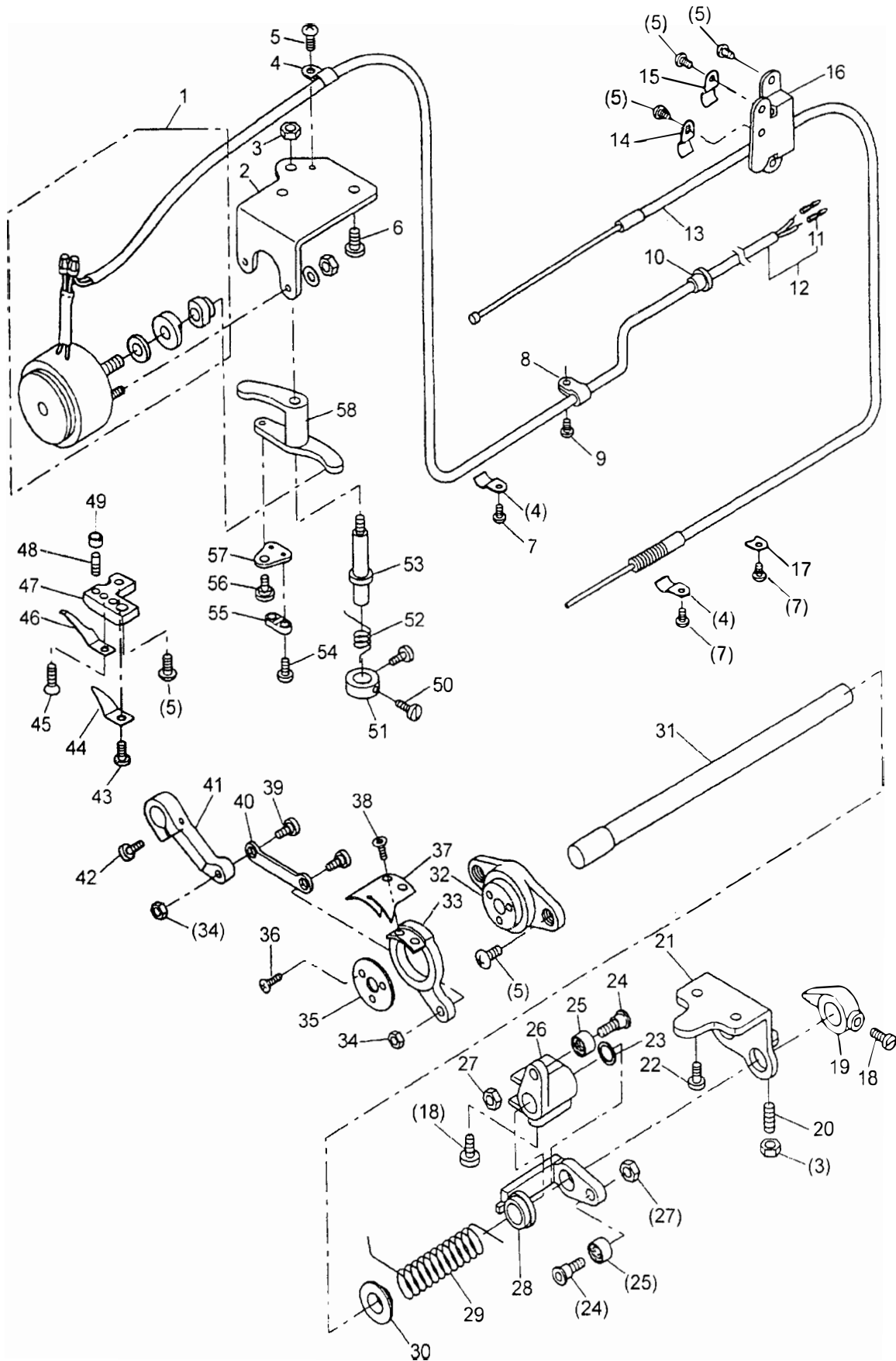

F.KNIFE ACTUATING MECHANISM

Fig. No.	Part No.	Description	Pcs.	Remarks
F44	HA7121N404	Thread finger	1	
F45	HA7121N304	Screw 9/64(40)×5	1	SM9/64(40)×5
F46	HA7121N204	Fixed blade	1	
F47	HA7121N104	Bracket for fixed blade	1	
F48	HA7121N604	Set screw 9/64(40)×8.5	1	SM9/64(40)×8.5
F49	HA7121N704	Nut 9/64(40)	1	SM9/64(40)
F50	HA7311CC06	Screw 9/64(40)×6.5	2	SM9/64(40)×6.5
F51	HA712N0696	Spring support collar	1	
F52	HA712N0697	Trimming lever spring	1	
F53	H6722K8001	Stud screw 15/64(28)×7.5	1	SM15/64(28)×7.5
F54	HA712N6912	Screw 1/8(44)×7	2	SM1/8(44)×7
F55	HA712N6911	Flexible wire presser	1	
F56	HA712N0699	Set screw 11/64(40)×5	1	SM11/64(40)×5
F57	HA712N6910	Flexible wire holder	1	
F58	H6721K8001	Thread trimmer driving lever	1	

G.TOUCH BACK MECHANISM & DETECTOR MECHANISM

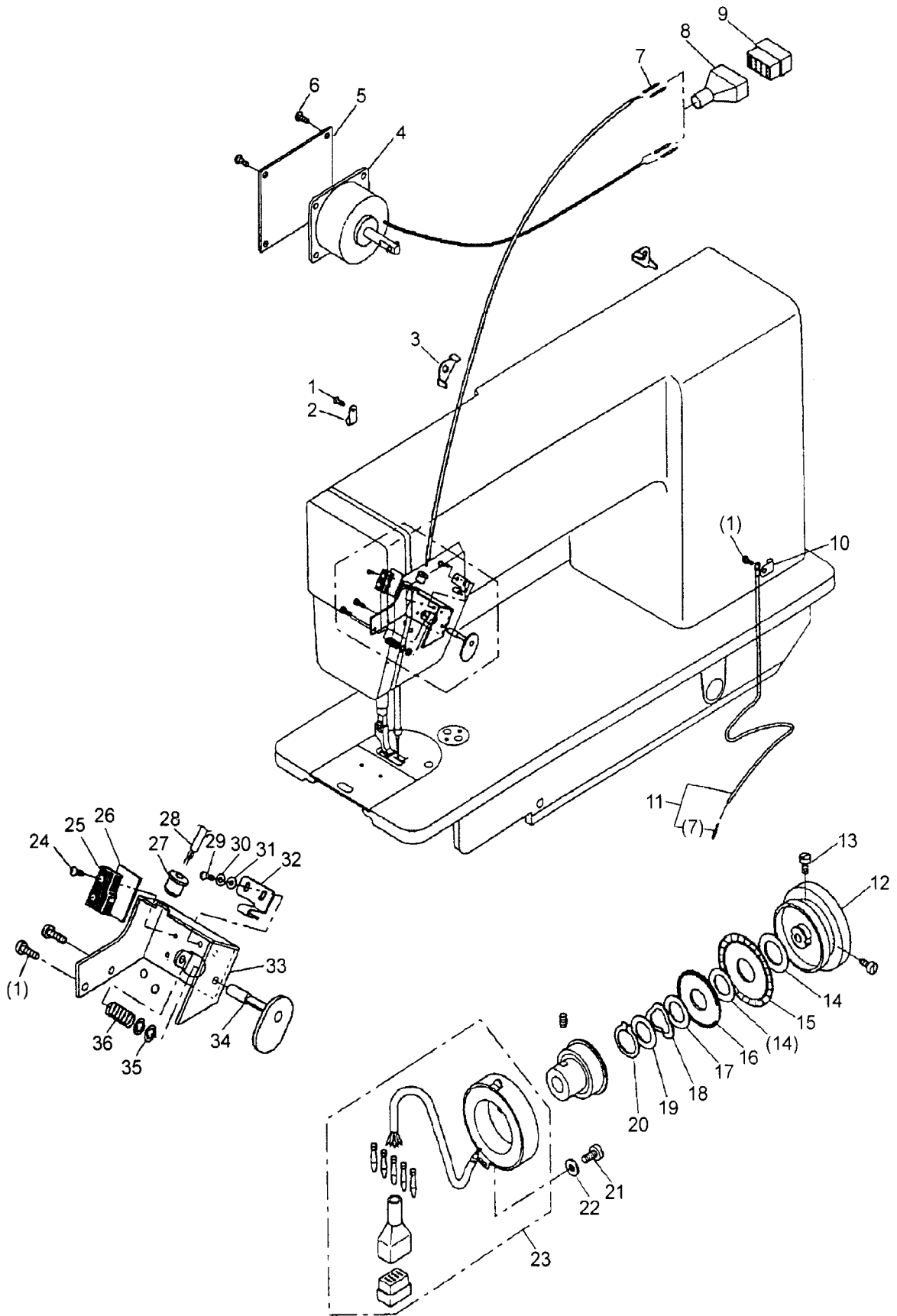

G.TOUCH BACK MECHANISM & DETECTOR MECHANISM

Fig. No.	Part No.	Description	Pcs.	Remarks
G01	HA300B2170	Screw 11/64(40)×8.2	4	SM11/64(40)×8.2
G02	H6727N8001	Cord holder	1	
G03	H6726N8001	Cord holder	2	
G04	HB2263B072	Solenoid	1	
G05	HB2264B081	Solenoid plate	1	
G06	HA300B2170	Screw 11/64(40)×8.2	4	SM11/64(40)×8.2
G07	HA7641B319	Terminal pin(male)	5	
G08	HA712Q0069	Connector cap	1	
G09	HA700Q0010	Nylon connector 12-pole	1	
G10	H6728N8001	Cord holder	1	
G11	HA705Q0065	Ground wire assy	1	
G12	H6706O7101	Pulley	1	
G13	HA110D0672	Screw 15/64(28)×12	2	SM15/64(28)×12
G14	HA700R0030	Spacer	2	
G15	HA700R0010	Speed command disc B12(down)	1	
G16	HA700R0020	Speed command disc B21(up)	1	
G17	HA700R0040	Spacer	1	
G18	HA700R0050	Supporter spring	1	
G19	HA700R0060	Washer 30	1	
G20	H007009300	Retaining ring-C type 30	1	
G21	HA300C2030	Screw 11/64(40)×8	1	SM11/64(40)×8
G22	HA703R0067	Washer	1	
G23	HA703R0065	Detector bracket assy	1	
G24	HA704O6510	Screw M2×8	2	M2×8
G25	HA704O0655	Micro switch	1	
G26	HA704O0658	Insulator seat	1	
G27	HA704O0657	Rubber plug Φ10	1	
G28	H67041.7101	Cord assy	1	
G29	HA704O0659	Screw M2×4	2	M2×4
G30	HA704O6511	Washer 2	2	
G31	HA704O6512	Washer 2	2	
G32	HA704O0654	Plate spring	1	
G33	HB22521.081	Bracket for touch switch	1	
G34	HA704O0021	Push button	1	
G35	H007013030	E-type stop ring 3	2	
G36	HA704O0653	Coil spring	1	

H.WIPER MECHANISM

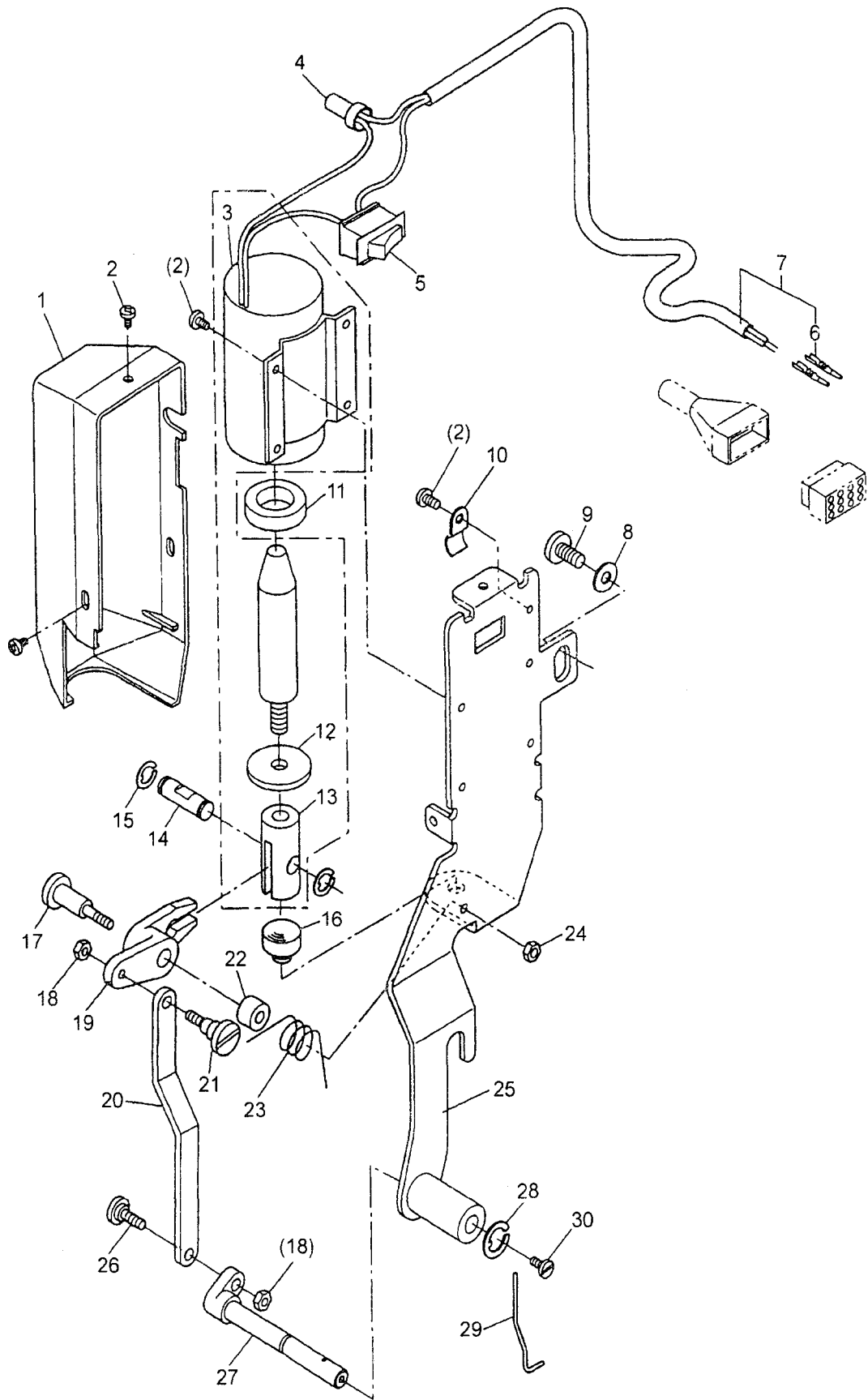

H.WIPER MECHANISM

Fig. No.	Part No.	Description	Pcs.	Remarks
H01	H6708M8001	Solenoid cover for wiper mech	1	
H02	HA708P0669	Screw -Sw-Pw M3×6	8	M3×6
H03	H6711M8001	Wiper solenoid	1	
H04	HA708P6610	Connecting 1-SD	1	
H05	HB2254M081	Thread wiper switch	1	
H06	HA7641B319	Terminal pin (male)	2	
H07	HA708P1011	Cord assy	1	
H08	HA700P0010	Washer 6	2	
H09	HA104F0654	Screw 15/64(28)×10	2	SM15/64(28)×10
H10	HA700P0060	Cord holder	1	
H11	H6713M8001	Rubber cushion	1	
H12	H6722M8001	Retain washer	1	
H13	H6712M8001	Joint	1	
H14	H6714M8001	Pin	1	
H15	H007013040	E-type stop ring 4	2	
H16	H6709M8001	rubber cushion	1	
H17	H6715M8001	Stud screw	1	
H18	HA710P0673	Nut 9/64(40)	2	SM9/64(40)
H19	H6716M8001	Wiper driving lever	1	
H20	H6720M8001	Thread wiper connecting rod	1	
H21	H6719M8001	Stud screw	1	
H22	H6717M8001	Spacer	1	
H23	H6718M8001	Spring	1	
H24	HA7111N304	Nut 11/64(40)	1	SM11/64(40)
H25	HB2253M081	Thread wiper bracket	1	
H26	HA710P0674	Screw 9/64(40)×9	1	SM9/64(40)×9
H27	H6721M8001	Wiper shaft	1	
H28	H007013050	E-type stop ring 5	1	
H29	HA705P0653	Thread wiper	1	
H30	HA104G0654	Screw 1/8(44)×6	1	SM1/8(44)×6

I.OIL LUBRICATION MECHANISM

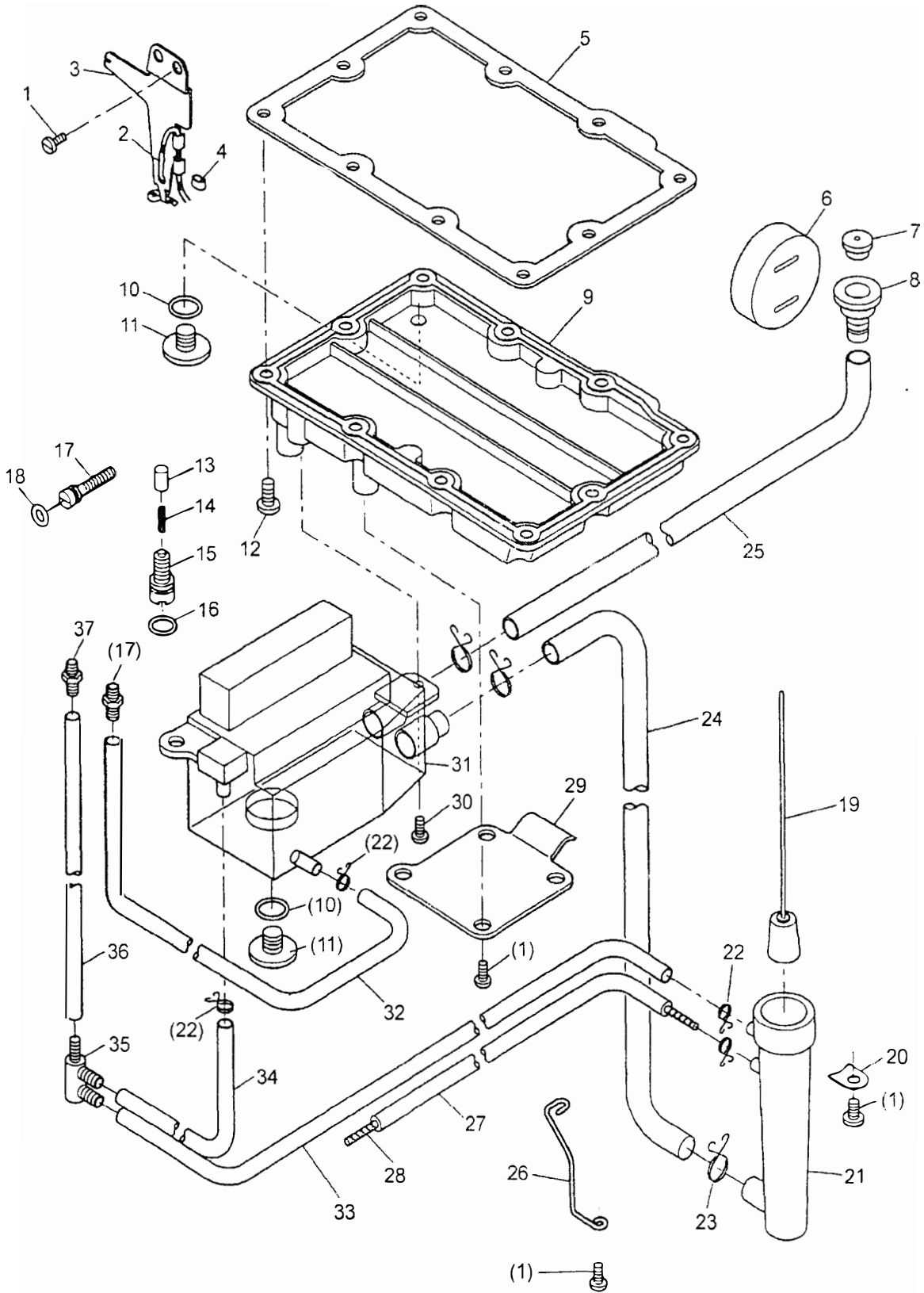

I.OIL LUBRICATION MECHANISM

Fig. No.	Part No.	Description	Pcs.	Remarks
101	HA300C2030	Screw 11/64(40)×8	9	SM11/64(40)×8
102	H6729P8002	Oil wick	1	
103	H6711P8001	Oil wick holder	1	
104	H3200G2030	Holder	1	
105	H6741B8001	Gasket for bottom cover	1	
106	H6722P8001	Oil sight window	1	
107	H6712P8001	Oil cap	1	
108	H6709P8001	Oil inlet	1	
109	H6740B8001	Bottom cover	1	
110	H6757B8001	O-ring	2	
111	H6707P8001	Screw 5/16(24)×8	2	SM5/16(24)×8
112	HA300B2160	Screw 11/64(40)×10	10	SM11/64(40)×10
113	HA300E2100	Plunger	1	
114	H6726P8001	Spring	1	
115	H6704P8001	Screw 5/16(24)×12	1	SM5/16(24)×12
116	HA705C0662	O-ring	1	
117	H6705P8001	Oil adjusting screw	1	
118	H6725P8001	O-ring	1	
119	H6719P7101	Floater	1	
120	H6733K8001	Washer	2	
121	H6718P8001	Floater case	1	
122	H6714P8001	Pipe holder	4	
123	H6714P8002	Pipe holder	3	
124	H6717P8002	Oil pipe	1	
125	H6717P8001	Oil pipe	1	
126	H6723P8001	Pipe holder	1	
127	H6716P8005	Oil pipe	1	
128	H6729P8001	Oil wick	1	
129	H6743B8001	Cover	1	
130	HA300B2170	Screw 11/64(40)×8.2	2	SM11/64(40)×8.2
131	H6713P8001	Oil tank	1	
132	H6716P8003	Oil pipe	1	
133	H6716P8004	Oil pipe	1	
134	H6716P8002	Oil pipe	1	
135	H6715P8001	Oil pipe connector	1	
136	H6716P8001	Oil pipe	1	
137	H6708P8001	Oil pipe connector	2	

J.ACCESSORIES

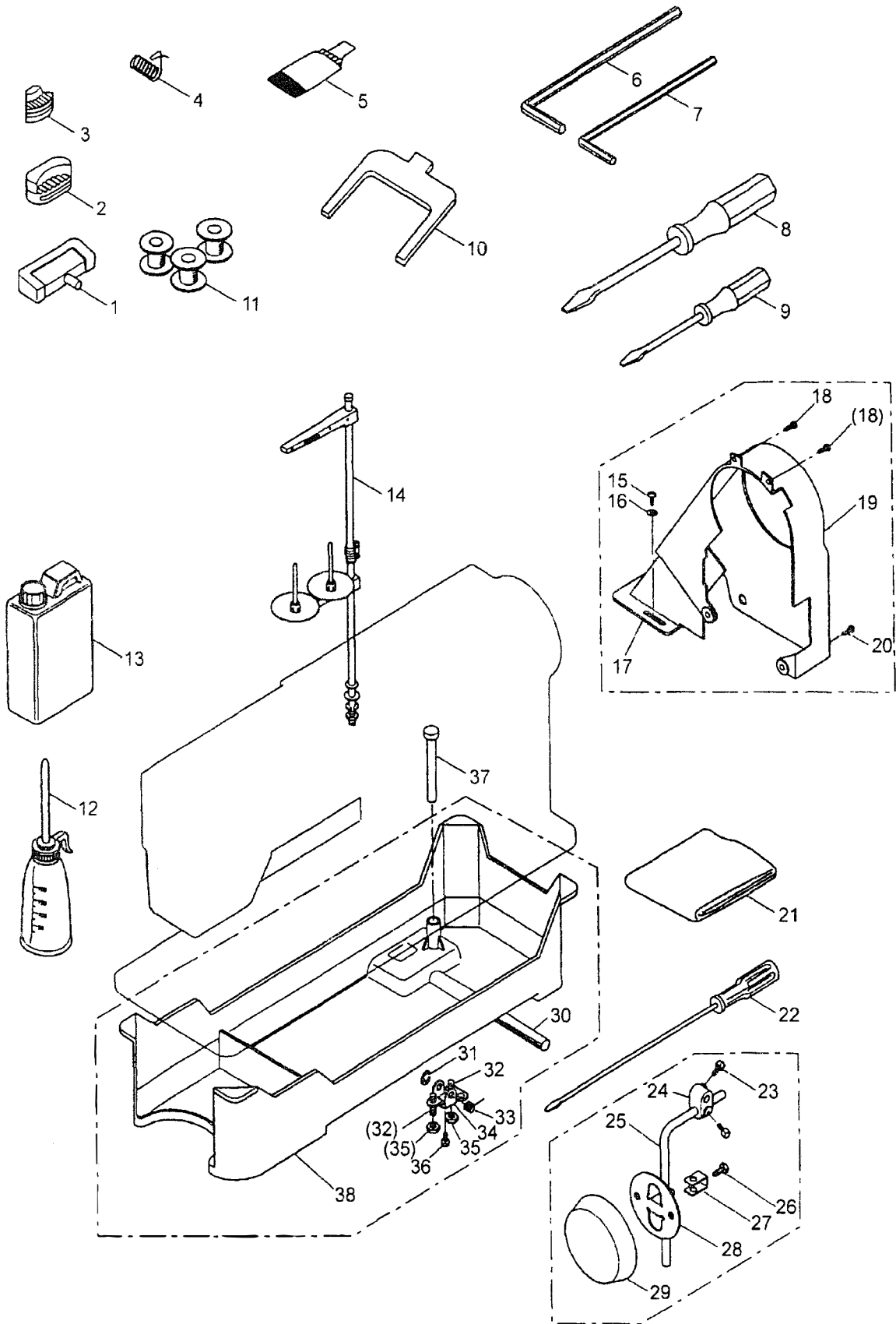

J.ACCESSORIES

Fig. No.	Part No.	Description	Pcs.	Remarks
J01	HA307J0067	Table hinge with rubber cushion	2	
J02	HA300J2050	Vibration preventing rubber	2	
J03	HA300J2060	Vibration preventing rubber	2	
J04	HA115B0706	Thread take-up spring	1	
J05	HA100C2160	Needle set (DB×1-2#14)	4	
J06	HS68990204	Hexagon socket screw key 3	1	
J07	HS68990202	Hexagon socket screw key 2	1	
J08	HA300J2200	Screw driver (middle)	1	
J09	HA300J2210	Screw driver (small)	1	
J10	HA704S0654	Speed command disc adjusting plate	1	
J11	HA700E2060	Bobbin	3	
J12	H6720Q8001	Oiler	1	
J13	HA100J2170	Oil can	1	
J14	HA707S0068	Thread stand assy	1	
J15	H801045200	Screw 4.5×20	2	
J16	HA300J2230	Washer	2	
J17	HA305J0665	Belt cover complete	1	
J18	HA300B2170	Screw 11/64(40)×8.2	2	SM1 1/64(40)×8.2
J19	H3705Q7101	Belt cover complete	1	
J20	HA300B2160	Screw 11/64(40)×10	2	SM1 1/64(40)×10
J21	HA100J2180	Cover	1	
J22	HA300J2070	Screw driver (large)	1	
J23	HA300J2180	Screw 5/16(28)×16	2	SM5/16(28)×16
J24	HA106J0663	Knee lifter coupling joint	1	
J25	HA106J0662	Knee lifter shaft	1	
J26	HA106J0667	Bolt 15/64(28)×8	1	SM15/64(28)×8
J27	HA106J0666	Knee lifter plate stopper	1	
J28	HA106J0665	Knee lifter plate	1	
J29	HA106J0668	Knee lifter cover	1	
J30	HA300J2160	Knee lifter shaft	1	
J31	H007013090	E-type stop ring 9	1	
J32	H6718Q8001	Set screw 15/64(28)×18	2	SM15/64(28)×18
J33	H6712Q8001	Spring	1	
J34	HA104J0658	Knee lifter	1	
J35	HA104J6510	Nut 15/64(28)	2	SM15/64(28)
J36	HA110J0672	Screw 15/64(28)×12	1	SM15/64(28)×12
J37	H6705Q8001	Knee lifter lifting rod	1	
J38	H6704Q8001	Oil reservoir	1	

SHANGHAI HUIGONG NO.3 SEWING MACHINE FACTORY

The description covered in this manual is subject to change for improvement of the commodity without notice

2004.2. Printed