



# ARTISAN®



**TORO-3200**  
with Ped 520  
Adjustable  
Pedestal Motor  
Drive



**TORO-3200 U**  
with U Table  
Adjustable  
Motor Drive



**TORO-3200**  
with Ped 500  
Adjustable  
Pedestal Motor  
Drive



**TORO-3200 BT**  
Bench Top  
Self Contained  
Transportable  
Heavy Duty Stitcher



**TORO-4000 LA-25**  
with Ped-600  
Adjustable  
Pedestal Motor Drive



**TORO-3000**  
with Ped 500  
Adjustable  
Pedestal Motor  
Drive



**TORO-4000 R**  
with Ped 500  
Adjustable  
Pedestal Motor Drive

## TORO-3000, TORO-3200 and TORO 4000 Series

### INSTRUCTION & SPARE PARTS MANUAL

# Table of Contents

## I. Operating Instructions

A.	Caution Warnings	Page 3.
B.	Specifications	3.
1.	CLEANING	4.
2.	LUBRICATION. Where to oil the machine.	4.
3.	HOW TO INSTALL THE NEEDLE	5.
4.	HOW TO TAKE OUT THE BOBBIN	5.
5.	HOW TO WIND A BOBBIN	5 and 31
6.	HOW TO INSTALL THE BOBBIN	6.
7.	HOW TO THREAD THE MACHINE	6 and 32
8.	ADJUSTING THE STITCH LENGTH	7.
9.	THREAD TENSION	7.
10.	THE THREAD TAKE-UP SPRING	7.
11.	ADJUSTING THE PRESSER FOOT PRESSURE	8.
12.	FEED DOG ADJUSTMENT	8.
13.	WALKING FOOT HEIGHT ADJUSTMENT	9.
14.	SHUTTLE AND NEEDLE TIMING ADJUSTMENTS	9, 9A, 9B, 10, 11, 12.
15.	FEED TIMING ADJUSTMENTS	12.
16.	TROUBLE SHOOTING GUIDE	13.

## II. Spare Parts List

1.	FRAME AND COVER COMPONENTS	16.
2.	MAIN SHAFT COMPONENTS	17.
3.	NEEDLE BAR & UPPER FEED COMPONENTS	18, 19.
4.	PRESSER BAR COMPONENTS	20, 21.
5.	FEED MECHANISM	22, 23.
6.	HOOK DRIVING SHAFT COMPONENTS	24, 25.
7.	TENSION COMPONENTS	26, 27.
8.	BOBBIN WINDER & THREAD GUIDE PARTS	28, 29, 33.
9.	KNEE LIFTER COMPONENTS	30.

**ADDITIONAL INSTRUCTIONS FOR  
TORO-3200 BT and TORO 4000 BT  
Located on Pages 33 and 35**

We Strive to Continuously Improve our Machinery. Specifications and features are constantly being updated. Your New TORO Stitcher may look slightly different then as shown in this pamphlet.

# ARTISAN®

## TORO-3000, TORO-3200 and TORO-4000

Extra Heavy Duty Cylinder Bed Lockstitch Compound  
Needle Feed Walking Foot Stitching Machines.

### CAUTION..... READ BEFORE OPERATING THIS MACHINE...

- |   |   |
|---|---|
| <ol style="list-style-type: none"> <li>1. Lubricate the Stitcher before operating!</li> <li>2. Confirm you are plugging the electric motor into the correct rated voltage.</li> <li>3. Confirm the machine and motor are turning over in a counter-clockwise rotation.</li> <li>4. Your Artisan TORO machine is normally set up with an SR-2 speed reducer/transmission to control your stitching speeds and to add additional torque to drive the needle into heavy leathers and fabrics at slow operating speeds.</li> <li>5. After operating the machine for more than 25 days, if desired, the top stitching speed may be increased to a maximum speed of 800 spm.</li> </ol> | <ol style="list-style-type: none"> <li>6. Keep your hands and all clothing away from the machine when pushing the button to turn the electric motor on.</li> <li>7. Switch on the Servo Motor and check for the LED light to illuminate.</li> <li>8. Always switch off the motor when finished sewing. Never leave the motor running while away from the machine.</li> <li>9. Always switch off the motor before changing needles or adjusting the sewing machine.</li> <li>10. The machine is a fine tool, not a toy. Do not let children operate the sewing machine.</li> </ol> |
|---|---|

### SPECIFICATIONS

USAGE	Saddle Stitching, Tack, Shoes, Boots, Saddle Bags, Harness.	NEEDLE	Schmetz 794 D or 794 S for Leather. For fabric 794
SEWING SPEEDS	Normal up to 600 spm. Max. 800 spm.	NEEDLE DIAMETER	# 110 to 250 # 18 to 27
STITCH LENGTH	0 to 11 mm	THREAD	Z-69 to 415 # 00 to # 6 cord
PRESSER FOOT LIFT <small>TORO-3200</small>	By Hand Lifter 15 mm By Foot Lifter 25 mm	STITCH ADJUSTING	Sliding Lever with Reverse
THREAD TAKE-UP SYSTEM	Cam type thread take-up lever	LUBRICATION	Manual Lubrication with Sewing Machine Oil
NEEDLE BAR STROKE	56 mm	MOTOR	Electronic Servo.

## 1. CLEANING

Normal stitching operation causes dust, lint, and dirt to build up around the moving parts of your TORO-3000, 3200 and 4000. Periodically clean around all the moving parts of the machine. Pay special attention to keeping the shuttle, shuttle race, and throat plate area clean.

Simply wipe off the build-up with a clean cloth or blow off the dirt with compressed air.

## 2. LUBRICATION

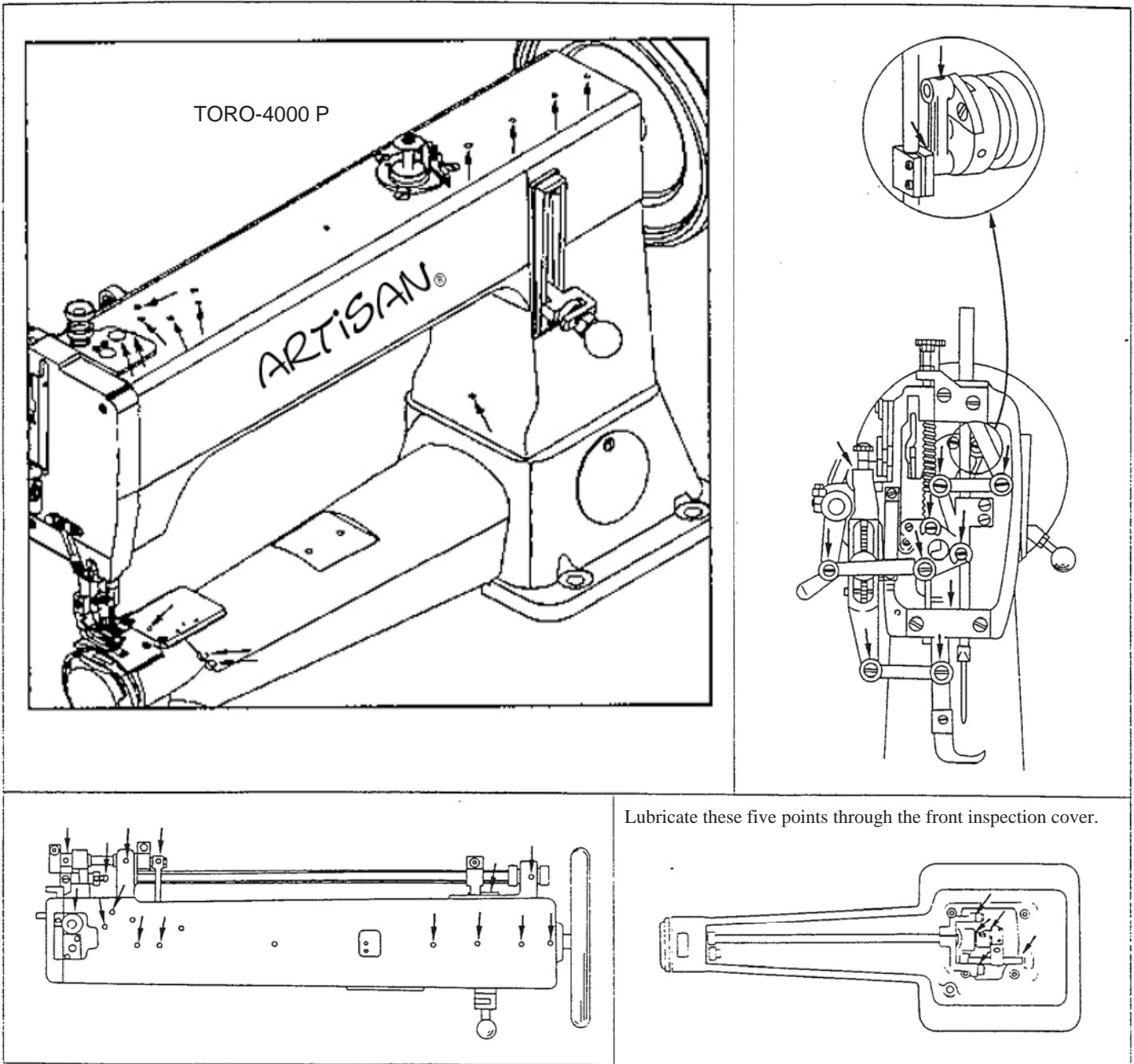

Your new ARTISAN® TORO-3000 and 4000 was thoroughly lubricated at our factory. However please re-lubricate the machine before putting the new stitcher into service.

The TORO-3000 and 4000 requires lubrication at the above points on a regular basis. Artisan recommends that the machine is oiled about every 7 to 12 hours of actual usage.

We suggest the best time to oil the machine is at the end of your work day. When you begin to use the machine the next time, simply wipe off the excess oil and the dirt or lint at the same time.

If sewing for prolonged periods of time oil the machine about every 5 to 7 hours.



### 3. HOW TO INSTALL THE NEEDLE

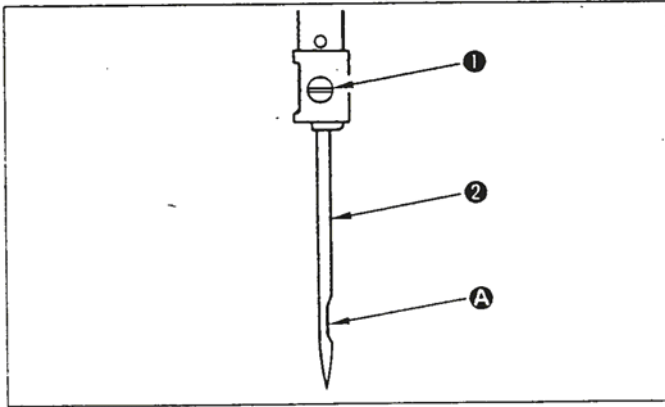

#### SWITCH OFF THE MOTOR BEFORE REMOVING OR INSERTING A NEEDLE

Artisan recommends that you use only "SCHMETZ" brand Needles.  
For Leather use size; **794 D, 794 S, 794 LR**  
For Canvas, Nylon and Fabrics use size: **794**

1. Turn the hand wheel counter-clockwise and raise the needle bar to its highest position.
2. Loosen the needle set screw #1 remove the old needle and insert a new needle #2 into the needle bar. Push it up into the hole as far as it will go.
3. Remember to locate the needle scarf #A towards the hand wheel and the long groove of the needle to the left side.
4. Securely tighten the needle set screw #1).

### 4. HOW TO TAKE OUT THE BOBBIN

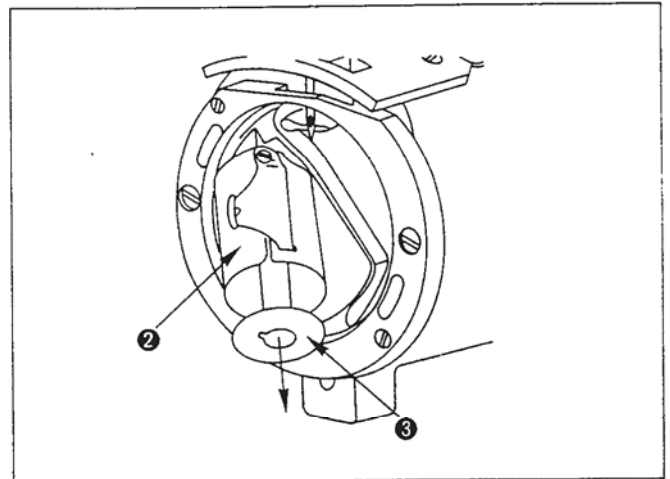
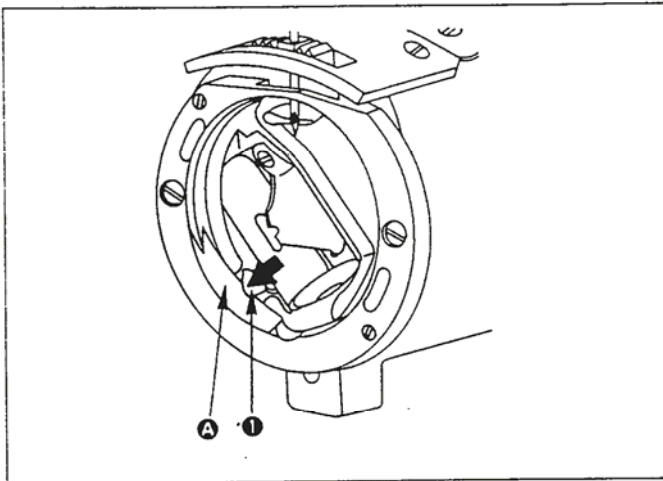

1. Turn the handwheel counter-clockwise until the needle reaches its lowest position.
2. Place your open left hand under the Shuttle area to catch the bobbin.
3. Depressing the retaining latch #1 will open the bobbin case.
4. Remove the bobbin being careful to leave the light weight beehive shaped bobbin push spring inside the bobbin case.

### 5. HOW TO WIND A BOBBIN THREAD of a TORO-3200 and TORO-4000

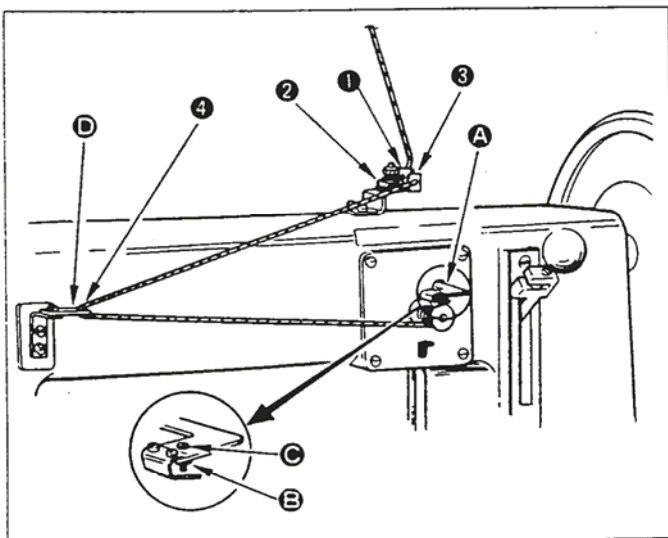

1. Raise the presser foot by the hand lifter lever.
2. Insert the bobbin into the bobbin winder spindle.
3. Thread the winder in the order illustrated and wind the thread onto the bobbin four or five turns.
4. Push the bobbin winder trip latch A down and the bobbin starts rotating to wind bobbin thread with the machine operated.
5. When winding of bobbin thread has been completed, the bobbin winder trip latch will be disengaged and the bobbin will stop automatically.

#### ★ Adjusting the amount of thread wound round the bobbin

That amount of thread has already been adjusted so that thread can be wound round approximately nine-tenths of the bobbin. If the amount is excessive or insufficient, adjust:

1. by loosening the adjusting screw and nut E .
  2. by turning the adjusting screw C .  
To decrease the amount, turn clockwise.  
To increase the amount, turn counterclockwise.
  3. After adjusting the amount, of thread has been completed, tighten the nut to secure firmly.
- ★ If bobbin thread is wound unevenly, move the bobbin winder thread guide B forward and backward so that thread can be wound evenly.

## 6. HOW TO INSTALL THE BOBBIN

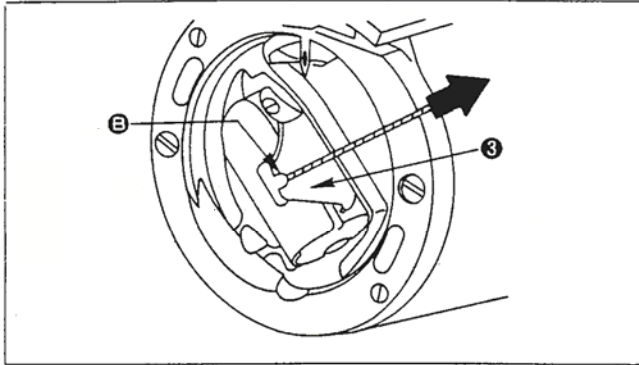
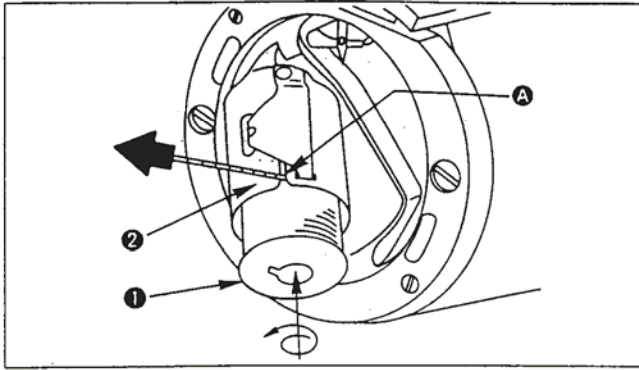

1. Pull approximately 3 to 4 inches of thread off the bobbin and insert the new bobbin into the bobbin case so that when turning the bobbin turns counter-clockwise.
2. Pass the thread through the slot <sup>#</sup>(A) of the bobbin case and pull the thread until the thread passes under the bobbin thread tension adjusting spring and rests in the groove as pictured.
3. Leave at least 3 to 5 inches of thread remaining and hanging out beyond the bobbin case.
4. Turn the handwheel counter-clockwise, with the needle threaded one revolution, and the bobbin thread will be pulled up through the needle plate.

## 7. HOW TO THREAD THE MACHINE HEAD (See Back Page for Greater Detail)

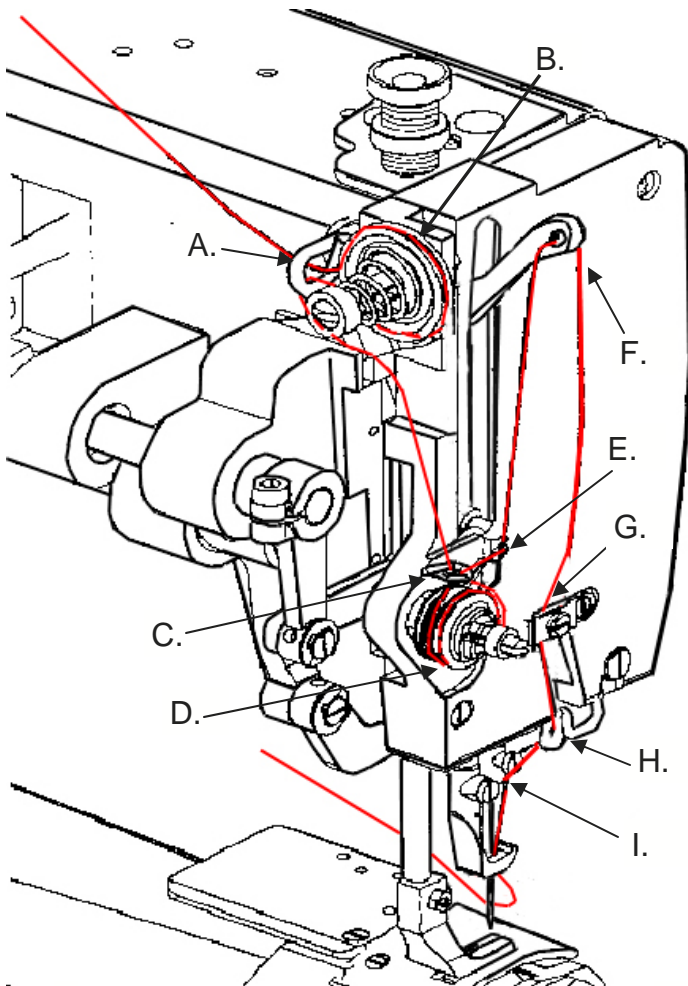

1. Place your spool of thread on the "thread stand" mounted to the rear of your machines table top. Normally located on the right hand rear corner of the sewing machines table top.
2. Pull some thread off the spool and thread it through the eyelet directly over the spool on the upper horizontal lever of the thread stand.
3. Pass the thread directly through the first thread guide <sup>#</sup>(A). Pull the thread over the top of the tension disks in a clockwise fashion and make certain that the thread slips between the two tension disks of the upper auxiliary tension assembly <sup>#</sup>(B).
4. Then place the thread back through the thread guide <sup>#</sup>(A).
5. Pull enough thread down and pass it through the middle thread wire guide <sup>#</sup>(C).
6. Wind the thread in a counter-clockwise direction around the main thread tension roller <sup>#</sup>(D) two complete revolutions and again back through the same thread guide <sup>#</sup>(C).
7. Then, pass the thread through the check spring <sup>#</sup>(E), located slightly to the right of the main tension <sup>#</sup>(C).
8. Pull additional thread up and pass it through the eyelet of the "Take-up" lever <sup>#</sup>(F) from the left side to the right side.
9. Then pull more thread down and pass the thread through the mid thread guide <sup>#</sup>(G) to the left side of the screw.
10. Continue through the lower casting thread guide <sup>#</sup>(H).
11. Then through the Needle Bar thread guide <sup>#</sup>(I).
12. Lastly, pass the thread through the eye of the needle from the left side of the needle to the right side of the needle towards the handwheel. About 7 or 8 inches of thread should extend beyond the needle.

Make one counter-clockwise revolution of the handwheel and pick up the bobbin thread above the needle plate.

**Please Hold the Bobbin and Needle Thread tautly in one hand while beginning to stitch the first two or three stitches.**

**Then release and trim the excess thread.**

## 8. ADJUSTING THE STITCH LENGTH AND REVERSE STITCHING

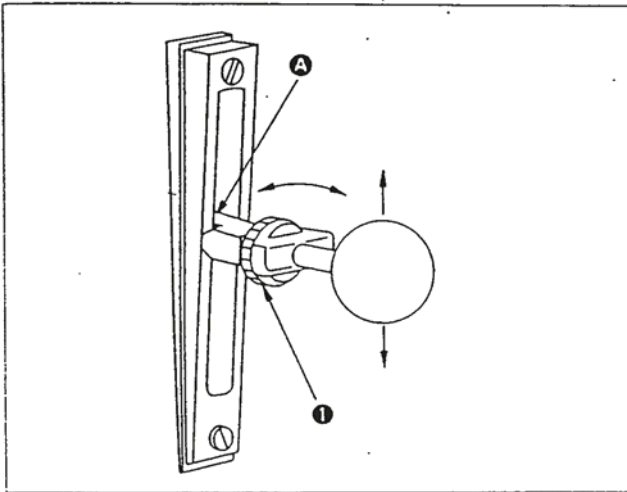

To Adjust the Stitch Length

1. Turn the adjuster nut <sup>#</sup>(1) counter-clockwise and push the handle in a downward direction for a longer stitch length.
1. For a shorter stitch length raise the handle and then turn the adjuster nut <sup>#</sup>(1) to lock in the handle.
2. A zero stitch length is in the middle of the slot. The longest stitch length is at the bottom of the slot located below #11 stamped on the face of the guide.
4. Pull the handle upwards to stitch in reverse. When the forward stitch length and the adjuster nut are set correctly, the machine will sew in an equal distant reverse stitch length.
5. To correctly back stitch in the same needle penetration holes; stop the machine with the needle down, then raise the needle approximately 1/4" upwards, pull the reverse handle all the way up, then make several stitches in reverse.
6. To sew forward, push the handle all the way down and sew.

## 9. THREAD TENSION

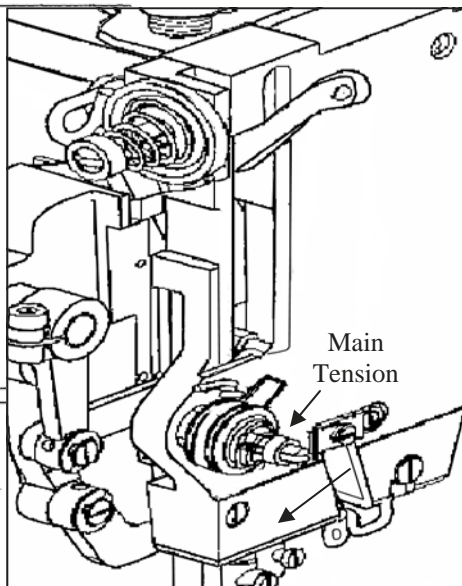
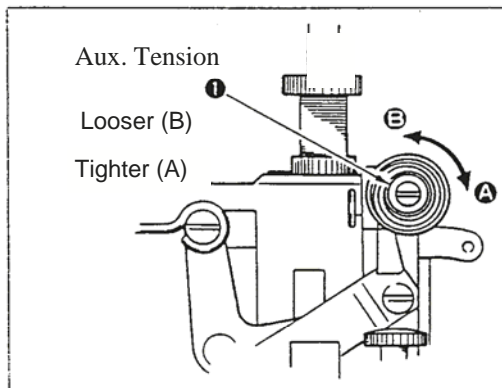

Adjusting the Needle Thread Tension:

- a. Turn the nut on the end of the Aux. Tension shaft in a clockwise direction to increase thread tension in small amounts <sup>#</sup>(A)
- b. Rotate the nut counter-clockwise to decrease the thread tension. <sup>#</sup>(B)
- c. For a greater amount of thread tension rotate the nut on the main tension device in a clockwise direction. To loosen rotate the nut counter clockwise.

If you have thread loops on the bottom side of your work, tighten the main tension. If the thread knot is on the top side of the work loosen the main tension. For minor adjustments adjust with the aux. tension.

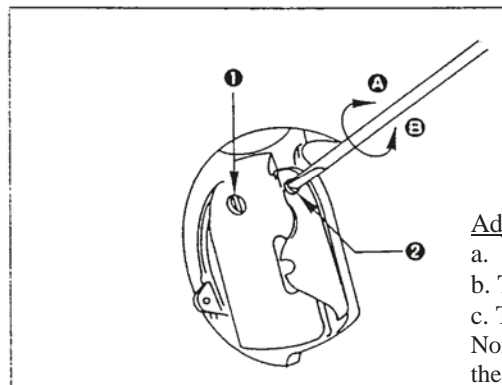

Adjusting the Bobbin Thread Tension:

- a. Loosen the locking set screw <sup>#</sup>(1) with a small screw driver.
  - b. Turn the spring tension adjusting screw <sup>#</sup>(2) clockwise for greater thread tension.
  - c. Turn the adjusting screw <sup>#</sup>(2) counter-clockwise to decrease the thread tension.
- Normally one does not need to re-adjust the bobbin case thread tension unless one changes the sewing thread to a very small diameter or size.

## 10. THE THREAD TAKE-UP SPRING

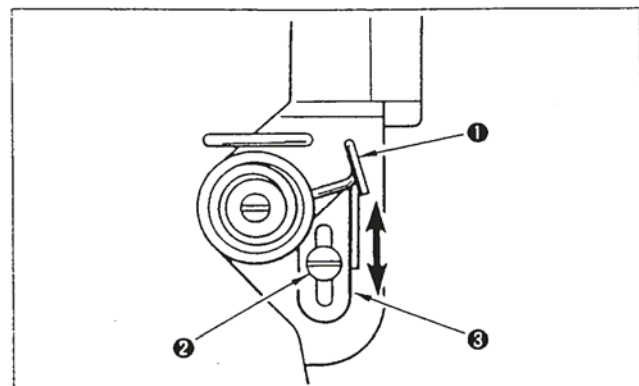

The Standard stroke of the thread take up spring, commonly called the check spring <sup>#</sup>(1) is from 8 to 10 mm or about 3/8".

Normally the stroke or spring tension does not require re-adjustment.



## 11. ADJUSTING THE PRESSER FOOT PRESSURE

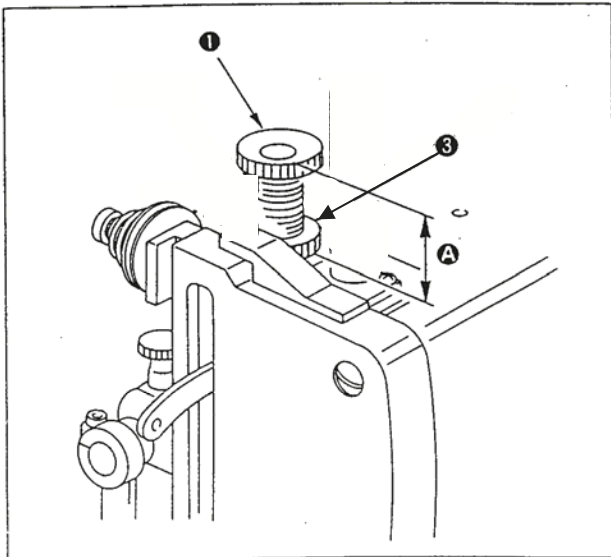

1. The outside presser foot pressure is adjusted by loosening nut # (3).
2. To increase the holding capacity of the Outside presser foot, turn the regulator # (1) clockwise.
3. To reduce the holding pressure, turn the regulator Counter-clockwise. Be care not to fully unscrew the regulator. It is spring loaded and will "pop" out.
4. Tighten the locking nut # (3).

The standard height of the presser foot regulator # (1) from the casting to the top of the regulator screw is about 5/8" to 3/4".

## 12. ADJUSTING THE HEIGHT OF THE FEED DOG

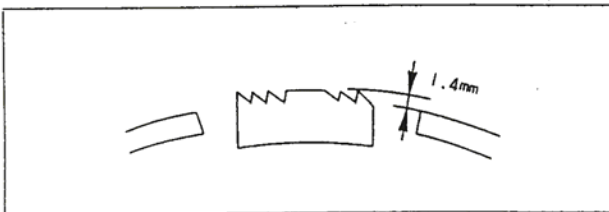

For Leather Stitching: The Feed Dog used in **ARTISAN** models TORO-3000, 3200 & 4000 R is smooth, without teeth so not to damage your leather. The TORO-4000 LA-25 and TORO 4000 P may use a different system.

For Fabric Stitching: All models should use a course tooth feed dog.

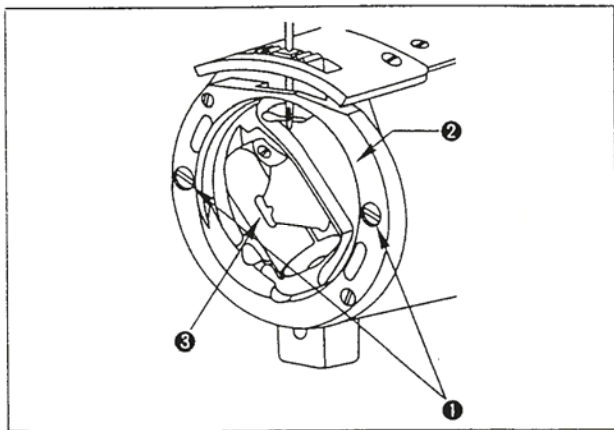

To adjust the height of the feed dog:

Either of the two methods are possible.

1. Open the bobbin case to reveal the feed dog attaching screw.
2. Loosen the screw # (4) and move the feed dog up or down as required.
3. Re-tighten the feed dog attaching screw.

OR a second method is to do the following:

3. Loosen and remove the two screws and small springs # (1) that hold the oscillating shuttle/bobbin case in place.
4. Remove the shuttle race and bobbin case from the casting and reveal the feed dog attaching screw.
5. Remove the Feed Dog attaching screw and Feed Dog to install any of the following except the standard needle plate.

Slotted Needle Plate (A) #43332 Stirrup Needle Plate (B) #43333  
Holster Needle Plate (C) #43334 Standard Needle Plate (D) #43337

Fabric Feed Dog w/teeth (E) 211-63400

Leather Needle Plate (F) 43337-L

Leather Smooth Feed Dog (G) 21163400-L

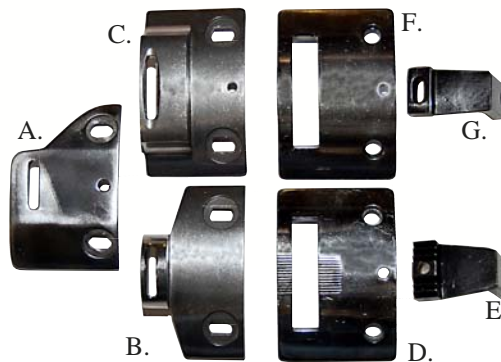
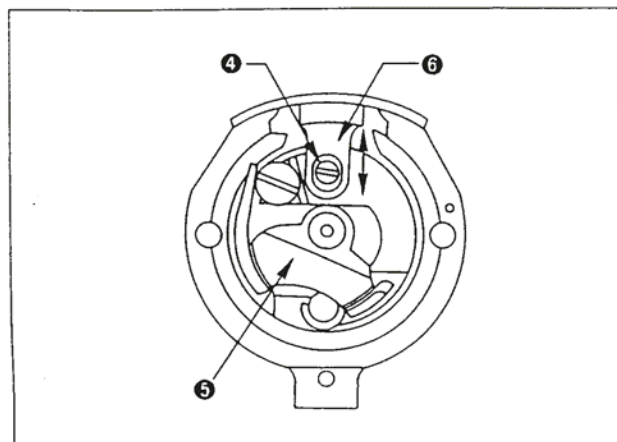



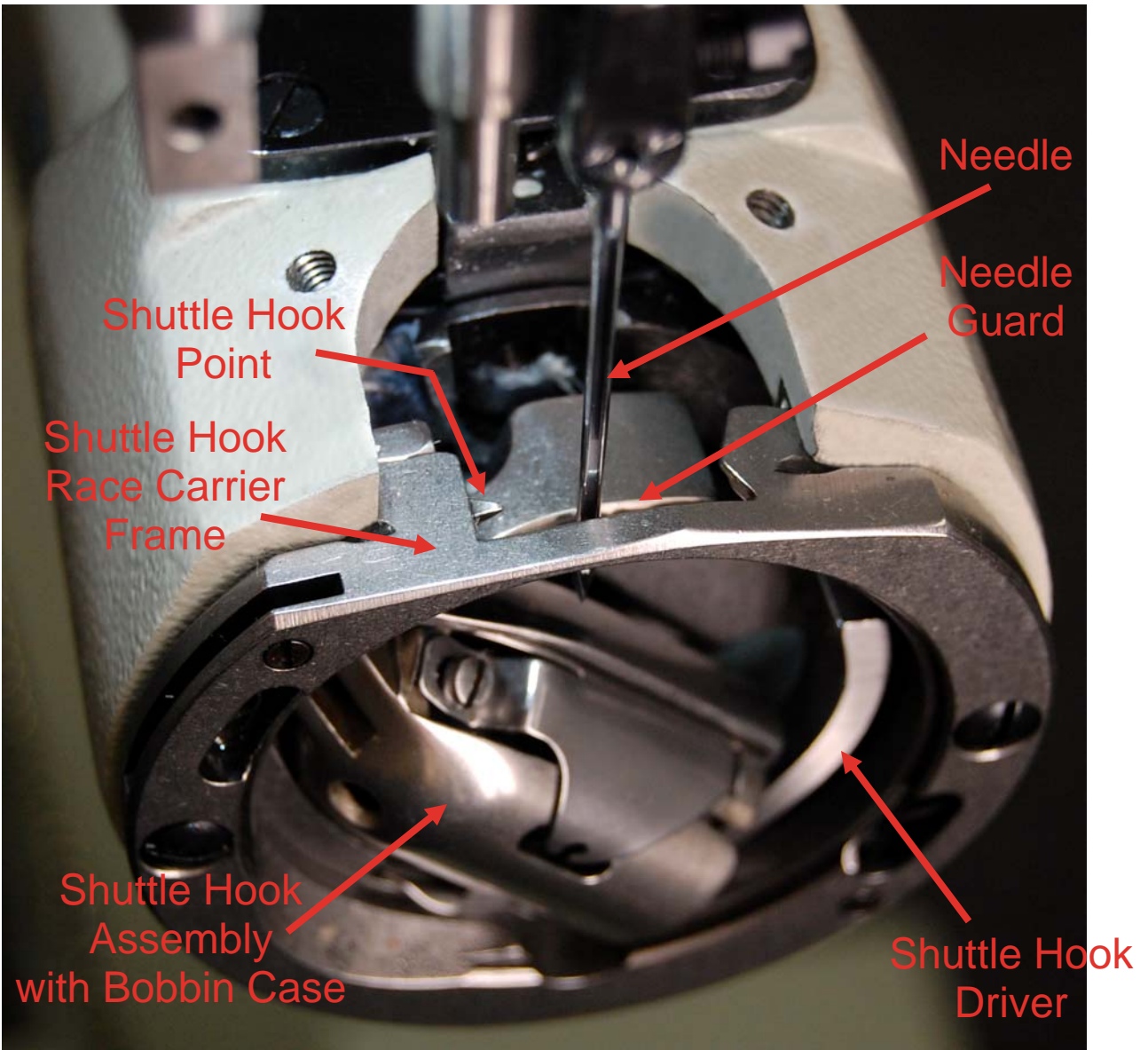

- A. Complete Oscillating Shuttle Hook Assembly with Bobbin Case.
- B. Shuttle Hook Point.
- C. Bobbin Thread Tension Adjusting Screw.
- D. Bobbin Thread Tension Adjusting Locking Set Screw.
- E. Bobbin Thread Tension Spring.
- F. Bobbin Case.
- G. Bobbin Case Opener Latch.

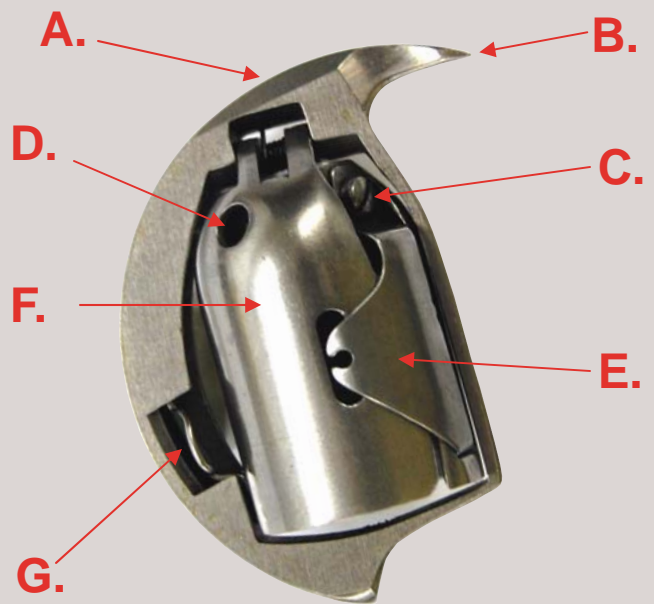

Photos Not To Scale. For Representation Purposes Only.

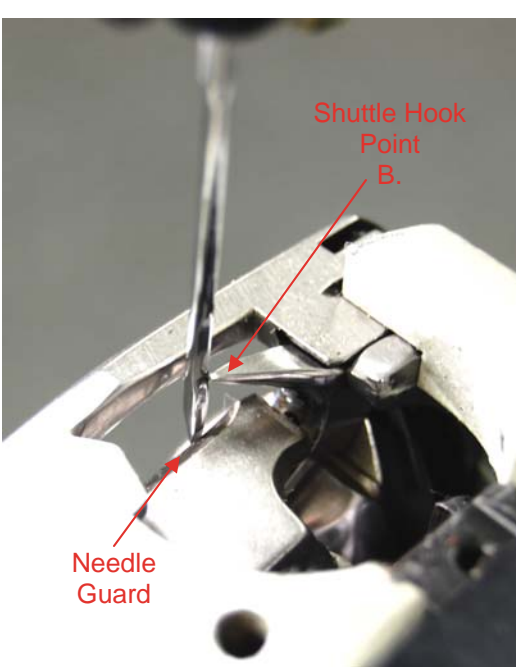

Shuttle Hook Point to the Needle Relationship as viewed from behind the needle on the rear left side, and from left to right.

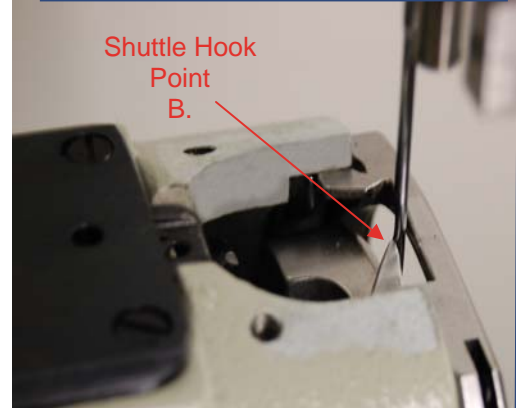

Shuttle Hook Point to the Needle Relationship as viewed from behind the needle and from the right to left side.

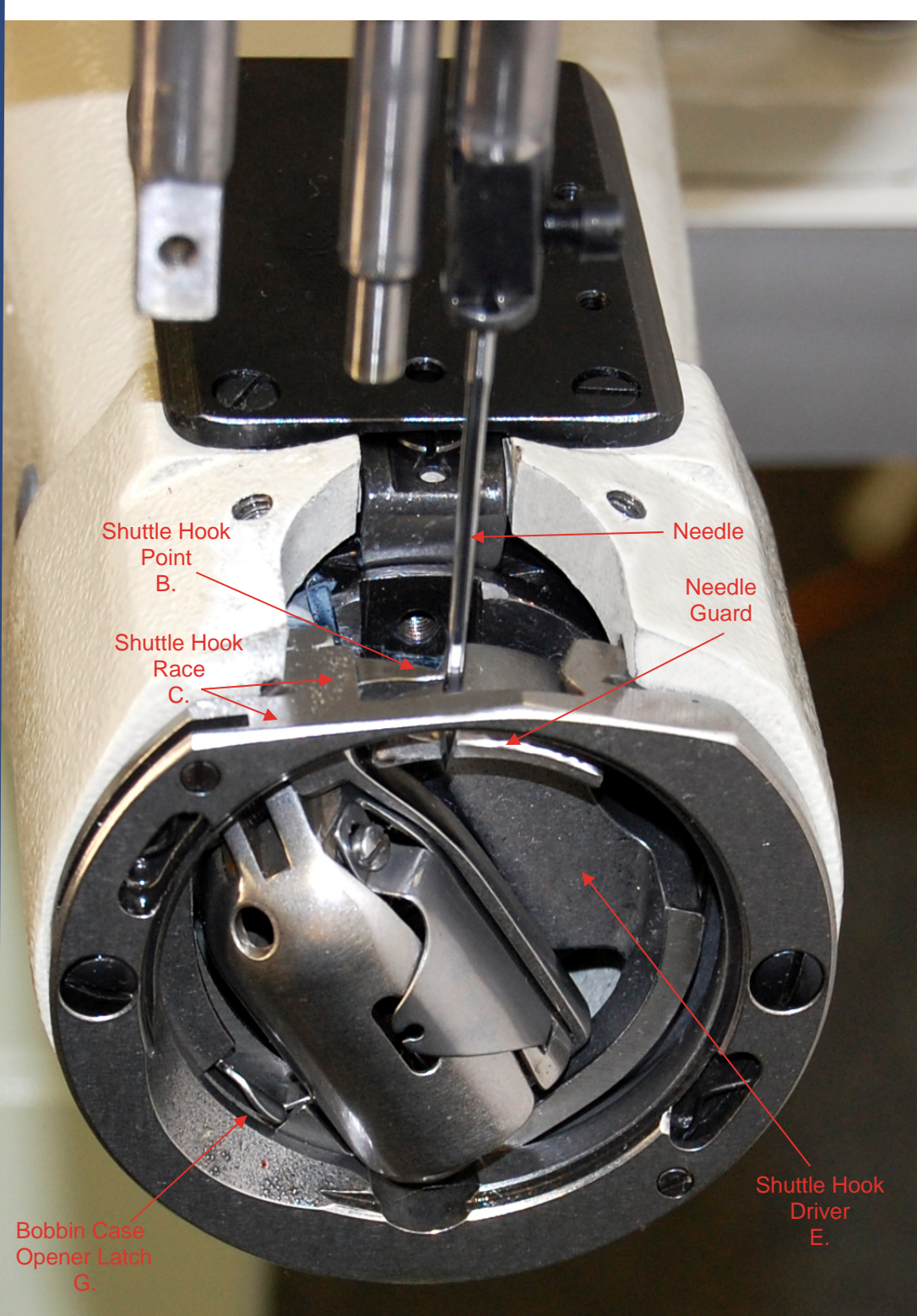

## SHUTTLE TO NEEDLE RELATIONSHIP:

**Correctly Timing the Needle with the motor switched off.**

Set the Stitch Length Lever to the "0" Position. Then turn the Handwheel in a counter-clockwise rotation and raise the needle bar from "Bottom-Dead-Center", the lowest position, up 4 mm or 5/32. The Shuttle Hook Point should now be directly behind and in the center of the Needle just above eye of the needle. At 4 mm up, the measurement from the bottom of the needle clamp to the top of the standard needle plate #43337 should be at 31 mm or 1-7/32".



## 13. WALKING FOOT HEIGHT ADJUSTMENT

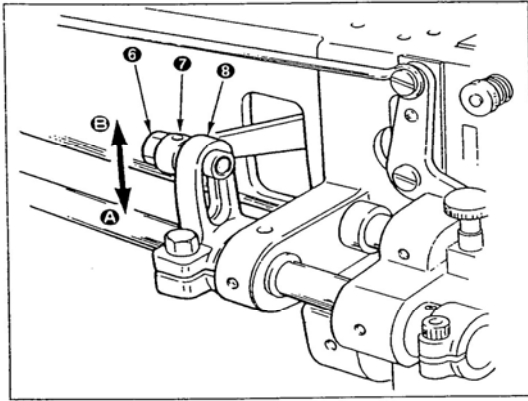

To Adjust the height of the walking feet:

1. Loosen the nut # (6) and move the lever # (7) up to Decrease the walking foot height. (B)
2. Move the lever # (7) down in slotted bracket # (8) to Increase the walking foot height. (A)
3. Tighten the nut # (6) after completing the adjustment.

## 14. ADJUSTING THE NEEDLE-TO-SHUTTLE RELATIONSHIP

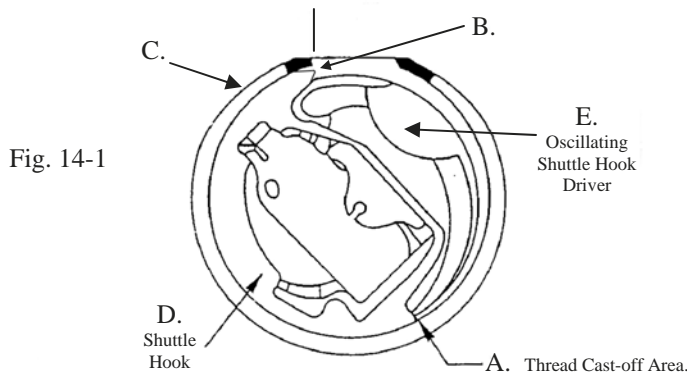

Normal timing adjustment of the shuttle hook.

1. Turn the handwheel counter-clockwise until the oscillating shuttle hook is positioned to the fullest most left position of its travel with the needle at the "Bottom-Dead-Center" of its travel (fully down).
2. The point of the oscillating shuttle hook # (B), should then be equal to 1 mm with the end of the steel shuttle hook race # (C).

**See Pages 9 and 10.**

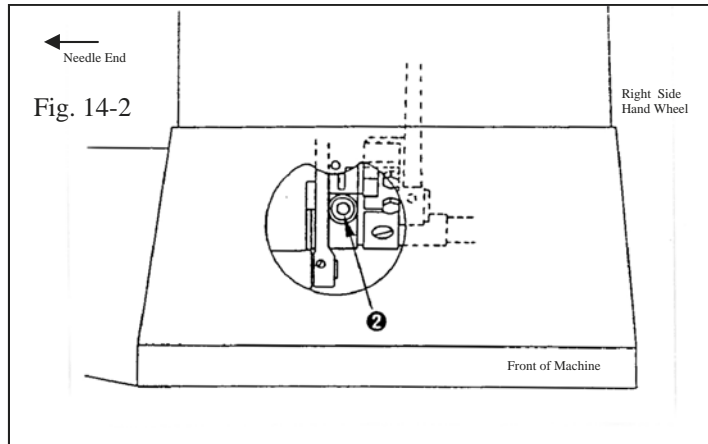

To Adjust the position of the oscillating shuttle hook.

1. Open the front inspection plate cover; located under the stitch length regulator lever on the front of the TORO machines' casting.
2. Insert a 6 mm Allen wrench into the adjusting screw # (2) and loosen the screw slightly. It is very **TIGHT!**
3. Fully loosen the Allen screw and rotate the shuttle hook either clockwise or counter-clockwise to align the shuttle hook correctly as shown in Fig. 14-1.
4. Remember to firmly tighten the Allen screw # (2) when you have accomplished the adjustment.

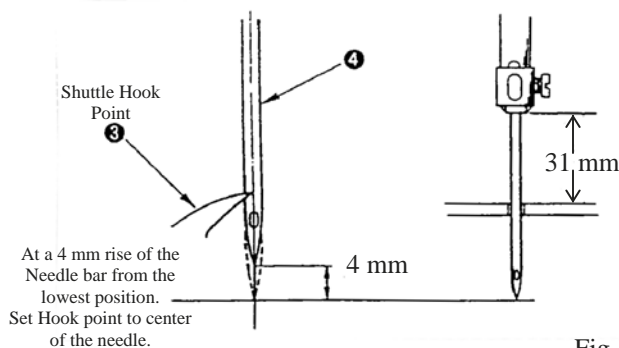

Needle Bar Height Setting: **27 mm**  
Bottom-Dead-Center or Lowest point of Needle Clamp  
to the top of the Throat Plate.

Fig. 14-3

To adjust the needle bar height and timing relationship:

1. Set the stitch length lever to the "0" position.
2. Turn the handwheel counter-clockwise until the needle bar is at its lowest position (bottom-dead-center).
3. Continue turning the handwheel in a counter-clockwise rotation and raise the needle bar up exactly 4 mm or approximately 5/32" up from "bottom-dead-center". The point of the shuttle hook # (3) should exactly bisect the center of the needle, and be approximately in the center of the needle, just above the eye of the needle and at the bottom 1/3 of the needle scarf. This adjustment is crucial to form a proper stitch.
4. At this point, the bottom of the needle bar should be exactly 31 mm or 1-7/32" above the top surface of the standard needle plate #43337.

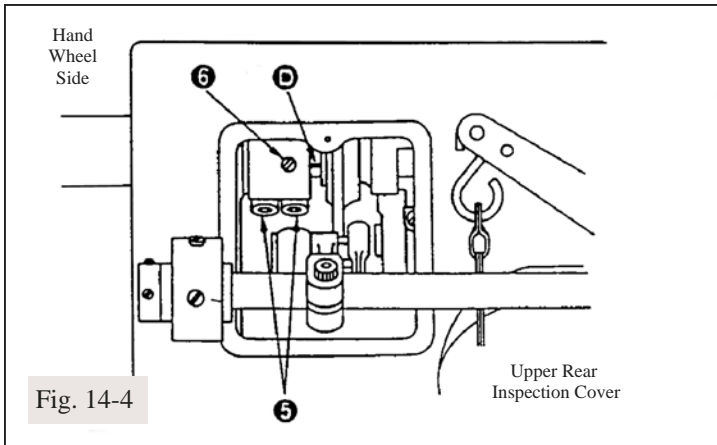

### Adjusting the Needle to Shuttle Position

1. Loosen the small Allen head screw #6. Then lightly snug the screw.
2. Loosen the two 6 mm Allen head screws #5.
3. With the stitch length lever set to the "0" position, turn the hand wheel in a counter-clockwise rotation and place the needle bar to the "Bottom-Dead-Center" position. At this point align Allen Screw #6 to the 9:00 O'clock position and in the same plane as the line "D" shown in Fig. 14-4.
4. Tighten the small Allen screw #6
5. Firmly tighten the larger Allen screws equally. First a little pressure on the right side screw. Then about the same pressure on the left side screw. Repeat this procedure in three or four steps until the two screws are TIGHT.

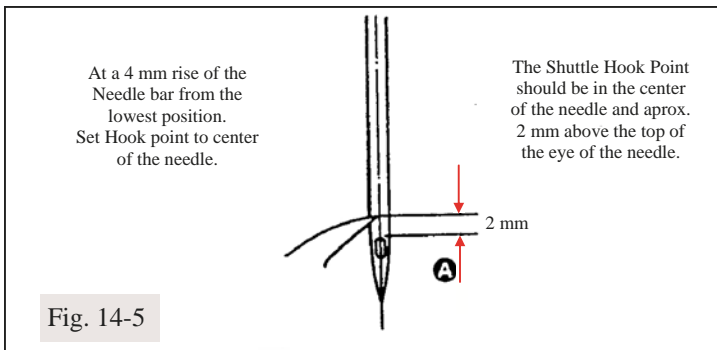

### Setting the Height of the Needle Bar

Set the needle bar height on the TORO-3000, 3200, 4000R or 4000 P as shown in Fig 14-5 at #(A).

The point of the shuttle hook should be set to the center of the needle after the needle rises up 4 mm from the "Bottom-Dead-Center" position .

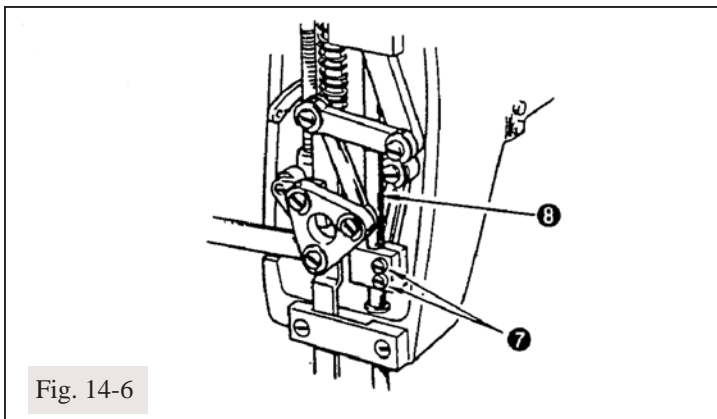

### To adjust the Height of the Needle Bar

#### Method 1

1. Turn the Handwheel in a counter-clockwise rotation until the shuttle hook point is aligned with the center of the needle.
2. Loosen Screws #7 in Fig. 14-6.
3. Move the Needle Bar in an up or down fashion to align the needle to the position in Fig. 14-5
4. Firmly tighten the 2 screws #7 Fig. 14-6.

#### Method 2

1. Turn the Handwheel in a counter-clockwise rotation until Needle is at "Bottom-Dead-Center".
2. Loosen Screws #7 in Fig. 14-6.
3. Align the needle so that the bottom of the needles eye is just above the "Needle Guard" shown on page 9 B with enough room for the thread to pass through the needle eye.
4. Firmly tighten the 2 screws #7 Fig. 14-6.

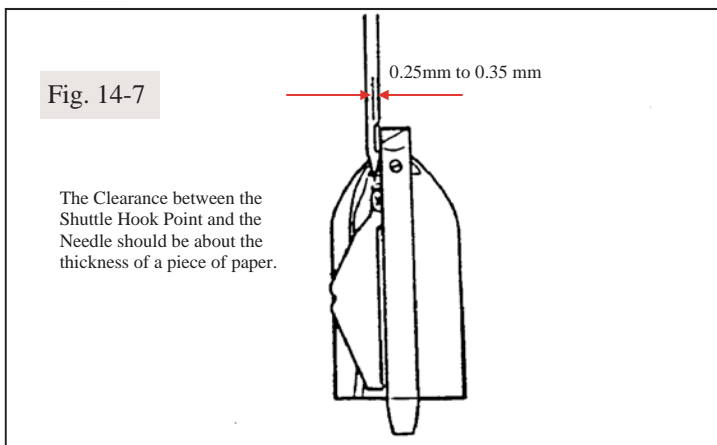

### Front/Back Needle to Shuttle Clearance

The clearance between the needle SCARF (recess) and the point of the shuttle hook is set at the factory between 0.25 mm and 0.35 mm depending on the diameter of the needle used. Clearance should not normally require adjustment. However, several optional Spacer Plates shown on page 24 with part number reference #6-44 are available for purchase if desired.



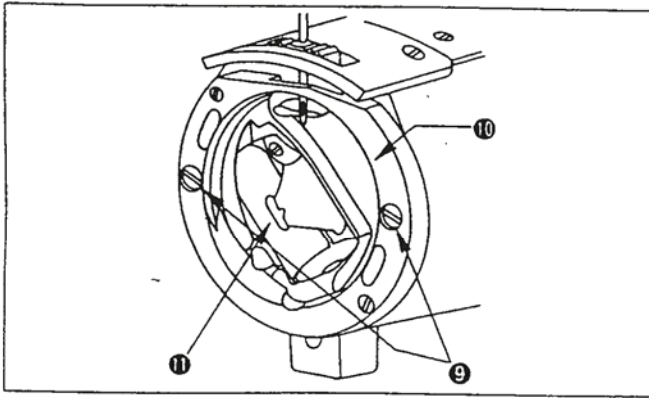

**To replace the shuttle race back,**

1. Remove two screws ⑨ in the shuttle race, remove shuttle race ⑩, and remove shuttle ⑪.

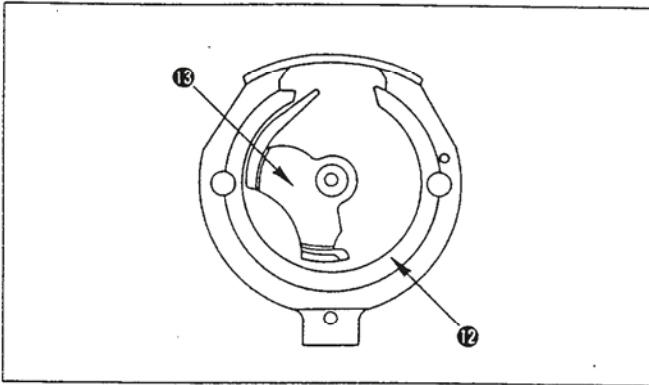

2. Turn the handwheel until shuttle driver ⑬ is brought to the position where shuttle race back ⑫ comes off. Then replace the shuttle race back.

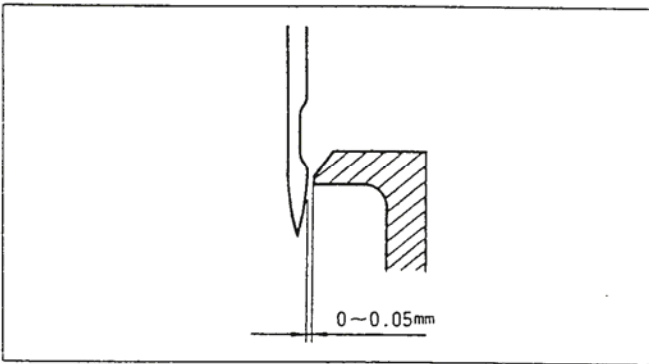

**\* Clearance between the needle and the shuttle driver**

The clearance between the needle and the needle guide of the shuttle driver has already been adjusted to the range of 0 through 0.05 mm.

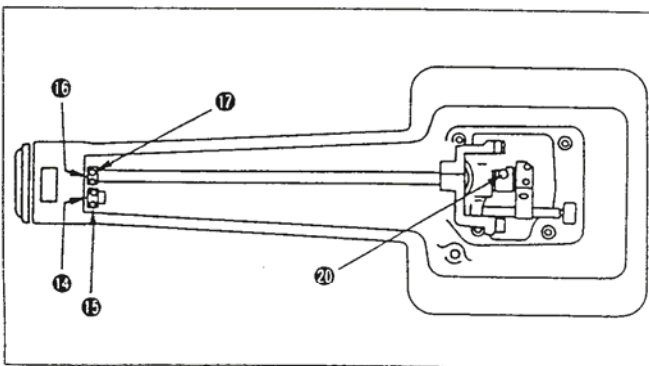

**To adjust the clearance between the needle and the shuttle driver:**

1. Loosen two screws ⑮, and remove thrust collar ⑭ of the feed rock driving shaft on the feed bracket.
2. Loosen two screws ⑰, and move thrust collar ⑯ of the feed rock shaft.
3. Loosen two screws ⑱ in the shuttle driving shaft thrust collar, screw ⑲ in the shuttle driving shaft front bushing and small pendulum clamping screw ⑳.

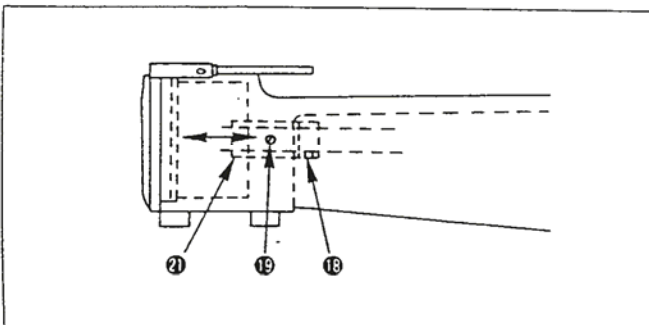

4. Adjust the clearance by moving shuttle driving shaft front bushing ㉑ to the left and right.
5. After the adjustment has been completed, secure the shuttle driving shaft thrust collar and the small pendulum, making sure there is no axial play of the shuttle driving shaft.
6. Finally, secure the respective thrust collars, making sure there is no play in the feed driving shaft and the feed rock shaft.

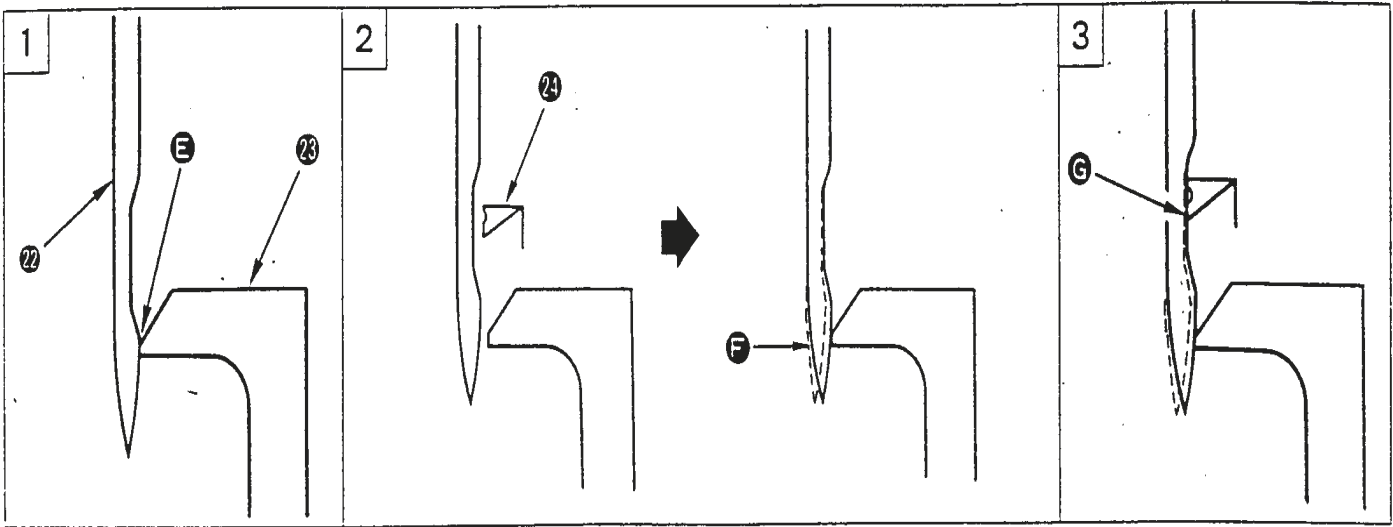

[ The standard for adjusting the clearance between the needle and the blade point of the shuttle ]

Use a standard Schmetz 794 (D or S) NM 200, #25 Needle

1. Adjust the clearance **E** between the convex section of needle **22** and shuttle driver **23** to 0.
2. Align the needle center with the blade point of shuttle **24** and press the **F** section of the needle against the shuttle driver.
3. Adjust the clearance **G** to a minimum, with the needle pressed against the shuttle driver, making sure that the needle does not contact the blade point of the shuttle.

\* By this adjustment the needle-to-shuttle blade point clearance will be 0.25 ~ 0.35 mm.

## 15. THE FEED DOG-TO-NEEDLE RELATIONSHIP

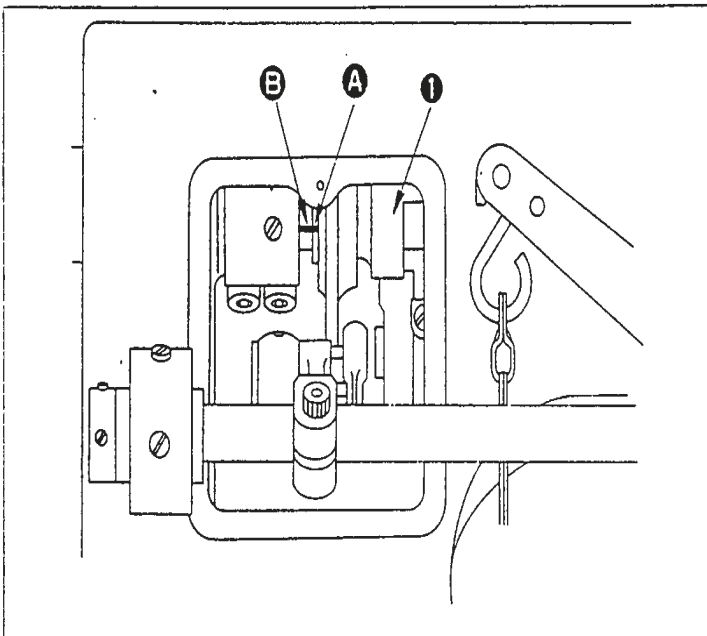

The standard timing between the feed dog and the needle is obtained when the feeding motion starts at the same time when the needle starts descending from its highest dead point.

★ To adjust the timing between the feed dog and the needle, follow the procedure stated below.

1. Loosen the two screws in feed eccentric cam **I**.
2. Align marker line **A** engraved on the side plate of the feed eccentric with marker line **B** engraved on the main shaft to obtain the standard timing.
3. After the adjustment, securely tighten the two screws in the feed eccentric cam.

The above adjustments are for stitching normal fabrics and do not apply to stitching heavy leathers for the TORO-3000 or 4000 R. Leather machines are specially adjusted for each application. The standard adjustments are only a starting point.

## 16. PROBLEMS WITH SEWING AND CORRECTIVE MEASURES

Problem	Cause	Corrective measures
1. The thread breaks or tends to fray and then break.	<ol style="list-style-type: none"> <li>1. A burr, cut, ruffness, or other imperfection was created on the needle plate, shuttle, shuttle race or presser foot by a broken or damaged needle.</li> <li>2. Needle thread tension excessively tight.</li> <li>3. Poor quality or incorrect thread size.</li> <li>4. Machine is out of synchronization.</li> <li>5. Excessive needle heat build-up.</li> </ol>	<ol style="list-style-type: none"> <li>1. Clean off and remove the flaw with a fine India stone or other abrasive.</li> <li>2. Loosen the upper thread tension.</li> <li>3. Always use a good quality pre-lubricated left twist sewing thread like "Rice" brand threads.</li> <li>4. Check and if necessary re-time the machine.</li> <li>5. Add an additional silicone thread lubrication system to your machine.</li> <li>6. Replace your needle with a new "Schmetz" brand quality sewing needle.</li> </ol>
2. Skipped Stitches	<ol style="list-style-type: none"> <li>1. The needle is too far away from the shuttle hook point.</li> <li>2. The shuttle hook timing is set too fast or too slow in relationship to the needle.</li> <li>3. The leather or fabric "jumps" up with the Needle. (called flagging)</li> <li>4. Bent needle, dull point, or improper needle diameter size for the leather sewn.</li> <li>5. The check spring tension is too hard or too soft.</li> <li>6. The check spring travel is too long or too short for the fabric sewn.</li> <li>7. The needle has overheated, lost temper or is dull or worn out.</li> <li>8. Excessive thread fraying or wear.</li> </ol>	<ol style="list-style-type: none"> <li>1. See Chapter 14, Adjusting the Needle-to-Shuttle Relationship.</li> <li>2. See Chapter 14, Adjusting the Needle-to-Shuttle Relationship.</li> <li>3. Tighten the presser bar adjuster screw.</li> <li>4. Replace with a new and correctly sized needle.</li> <li>5. Decrease the check tension.</li> <li>6. Adjust the check spring travel for the weight of the fabric or leather being sewn.</li> <li>7. Replace the needle with a Schmetz brand #794 Needle. Inferior quality needles cause problems.</li> <li>8. Replace poor quality thread with RICE or Artisan "Premium Performance Leather Stitching Thread" from Artisan Sewing Supplies. 888 838 1408</li> </ol>
3. Improper thread tension, irregular looking stitches, or excessive bobbin thread tension.	<ol style="list-style-type: none"> <li>1. Worn out thread guides.</li> <li>2. The bobbin jams.</li> <li>3. Weak bobbin thread tension.</li> <li>4. Bobbin thread is wound to tightly.</li> <li>5. Bobbin thread showing on top of fabric or leather</li> <li>6. Loops showing on the bottom of the leather or Fabric.</li> </ol>	<ol style="list-style-type: none"> <li>1. Repair the guide or replace with a new thread guide.</li> <li>2. The bobbin may be bent or otherwise damaged. Replace the bobbin.</li> <li>3. Tighten the bobbin thread tension, Chapter 9</li> <li>4. Loosen the tension on the bobbin winder</li> <li>5. Loosen the Needle Thread Tension, Chapter 9</li> <li>6. Tighten the needle thread tension, Chapter 9</li> </ol>
4. Excessive Thread Abrasion	<ol style="list-style-type: none"> <li>1. Worn out or Incorrect needle size</li> </ol>	<ol style="list-style-type: none"> <li>1. Replace the Needle</li> </ol>

5. Stitches are out of line or do not track straight.	<ol style="list-style-type: none"> <li>1. Incorrect point for the leather being sewn.</li> <li>2. Dull or blunt needle point.</li> </ol>	<ol style="list-style-type: none"> <li>1. Replace your needle with one with the correct cutting point for the type of leather being sewn. Read and understand the Schmetz Leather Needle Pamphlet available from Artisan 888 838 1408</li> </ol>
---	--	--

6. The bobbin thread tension will not adjust.	<ol style="list-style-type: none"> <li>1. Lint or debris trapped under the bobbin case spring tension.</li> </ol>	<ol style="list-style-type: none"> <li>1. Remove the bobbin case spring and clean out the Debris.</li> </ol>
---	---	--

7. The v-belt from the SR-2 speed controller is slipping or the hand wheel does not turn when the motor is fully engaged	<ol style="list-style-type: none"> <li>1. The v-belt has stretched.</li> <li>2. The v-belt is worn out</li> <li>3. The machine is jammed.</li> </ol>	<ol style="list-style-type: none"> <li>1. Lower the SR-2 Speed controller. Make the belt tension tighter.</li> <li>2. Replace the v- belt</li> <li>3. Clean out the foreign blockage. Perhaps a small piece of thread is trapped in the shuttle raceway.</li> </ol>
--	--	---

**When in doubt...**  
**Call ARTISAN®**  
**for Help! 888-838 1408**

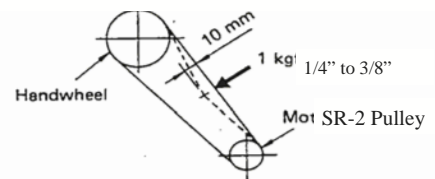

**SUGGESTED**  
**REFERENCE GUIDE FOR**  
**ARTISAN® TORO 3000, 3200, 4000 R, Series**  
**LEATHER STITCHING MACHINES**  
**Recommended Schmetz brand Needle #794**

1. Sewing on Thin Leathers of less than 8 oz. or up to 1/8":  
 Use Schmetz brand Needles number 794 D or S, NM:160 Size 23, Canu 53:20MF1.  
 "D" is a Triangle Leather Point and "S" is a Spear Point for leather.  
 Under normal conditions the "D" points will last longer and the "S" point needles have a shorter life span but will make a straighter stitch.  
 We recommend using thread sizes 69, 138, or 207. Size 277 might be too heavy.  
 The same size thread as in the needle or one size smaller for the bobbin thread will give you more yield from the bobbin.
2. Stitching Leathers from 8 oz. to 12 oz or from 1/8" to 3/16":  
 Use Schmetz brand Needles number 794 D or S, NM:160 or 180, Size 23 or 24, Canu 53:20MF1.  
 "D" is a Triangle Leather Point and "S" is a Spear Point for leather.  
 We recommend using thread sizes 138, 207, or 277 and either the same size thread as in the needle or one or two sizes smaller thread in bobbin is recommended.
3. Leather from 12 oz to 16 oz., 3/16" to 5/16":  
 Use Schmetz brand Needles number 794 D or S, NM:180 or 200, Size 24 or 25, Canu 53:20MF1.  
 We recommend using thread sizes 207, 277, or 346 and either same size thread as in the needle or one or two sizes smaller thread in bobbin for additional yield.
4. When stitching multiple plies of Leather beyond 7/16," we recommend the use of Schmetz brand 794 "D" point needle of at least a diameter of #25 (200). Any size thread may be used. However, the use of 207, 277, or 346 is recommended in the needle and one or two sizes smaller thread in the bobbin.

**NOTE:**

Your Bobbin Thread tension will require readjustment when using smaller thread diameters such as size 69 or 138 in the bobbin.

**SADDLE SKIRTING:** 794 D #25 (200) Needle  
 Thread 277 or 346 in the Needle  
 138, 207, OR 277 in the Bobbin

**HARNESS:** 794 D #24 (180) or #25 (200) Needle  
 Thread 207, 277, or 346 in the Needle  
 138, 207 or 277 in the Bobbin

**HOLSTERS:** 794 D #25 (200) NEEDLE  
 Thread 207 or 277 in the Needle  
 138, 207 or 277 in the Bobbin

**SHEATHS:** 794 D #24 (180) or #25 (200) Needle  
 Thread 207, 277, or 346 in the Needle  
 138, 207, 277 in the Bobbin

**CHAPS:** 794 S #24 (180) Needle  
 138 or 207 in the Needle  
 138 or 207 in the Bobbin

**BELTS:** 794 D #24 (180) Needle  
 Thread 138 or 207 in the Needle  
 138 or 207 in the Bobbin

**PURSES:** 794 D #24 (180) Needle  
 138 or 207 in the Needle  
 138 or 207 in the Bobbin

**MENUS, CHECKBOOKS, BOOK JACKETS, etc**  
 Round Point Needles 794 #22 (140)  
 Thread 69 or 138 in the Needle and Bobbin.

**NOTE:**

Change your needle to a non leather point needle when stitching fabrics other than leather.

**ARTISAN** recommends using a Schmetz brand #794 size 22, 23, or 24 needle on Canvas, Upholstery Fabrics, or Webbing. For Stitching "Bio-Plastics" use a needle 2 diameters larger than for leather. You must replace the leather presser feet, feed dog and needle plate with a "Blanket Set" for stitching on other than leather.

**ARTISAN** strongly recommends replacing your needle every 8 to 10 hours of actual stitching!

Leather Point Needles are like "knives". They get dull and require replacement.

Cutting point needles create significant heat going through heavy leather. Needles lose their temper (hardening) with heat and that leads to bending or broken needles. A broken needle may cause damage to your machine.

The potential damage to both your project and your machine will far outweigh the approximately \$1.<sup>00</sup>

Cost of replacing a damaged needle. Think of it a affordable preventative maintenance.



Spare Parts  
List

ARTISAN®

**TORO-3000,  
TORO-3200  
and  
TORO-4000**

# 1. FRAME AND COVER COMPONENTS

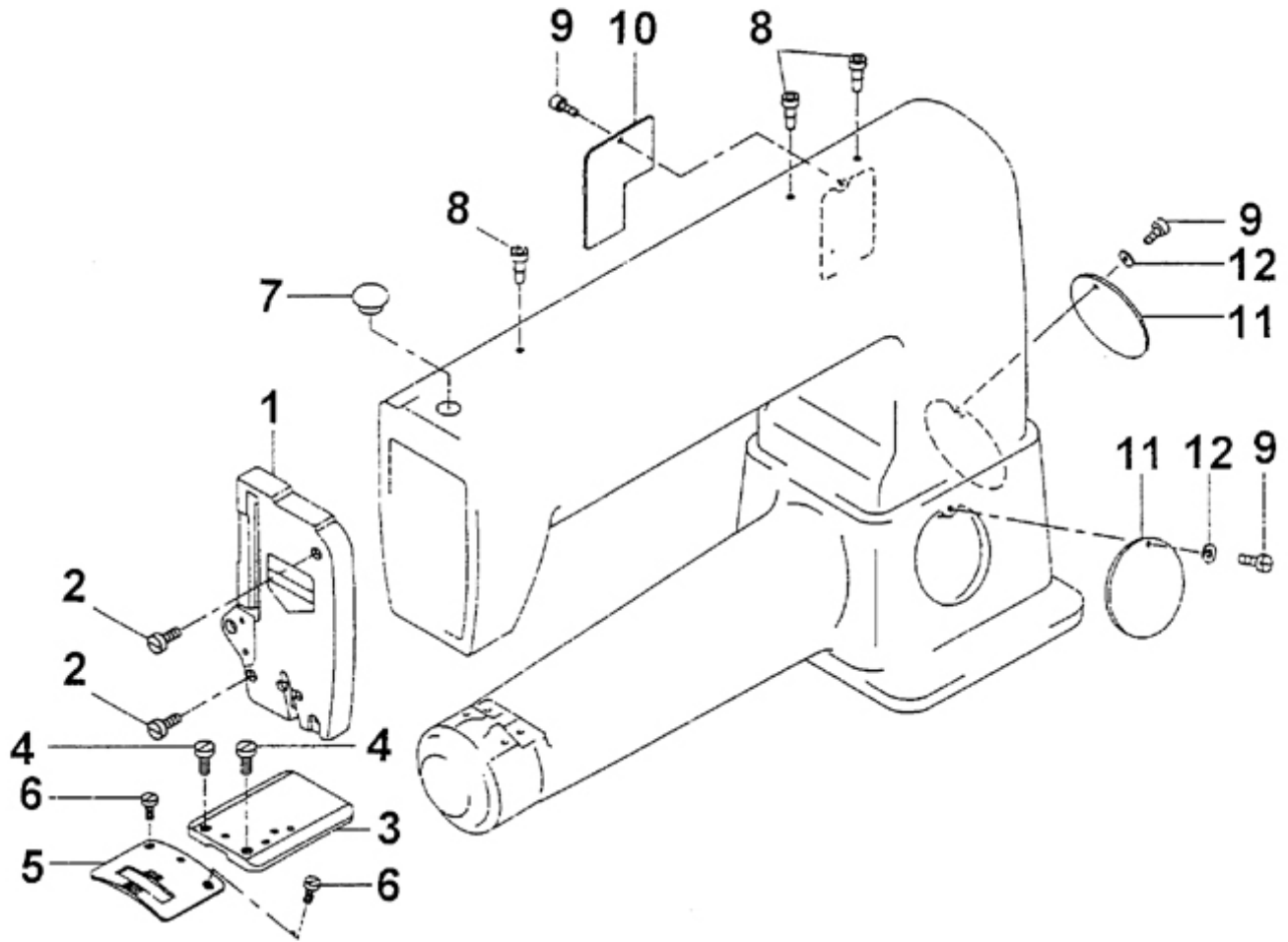

REF. NO.	NOTE	PART NO.	DESCRIPTION	ANT.
1.		210-90253	FACE PLATE ASM.	1
2.		SS-6151920-SP	SCREW 15/64-28 L=19.0	2
3.		211-51006	SLIDE PLATE	1
4.		SS-7111110-TP	SCREW 11/64-40 L=10.5	2
5.		211-60205	NEEDLE PLATE	1
6.		SS-7120910-SP	SCREW 3/16-28 L=9	2
7.		TA-1250406-RO	ROBBER PLUG	1
8.		B1156-026-000	OIL PIPE	3
9.		SS-7090710-SP	SCREW 9/64-40 L=6.8	3
10.		211-60106	SIDE COVER B	1
11.		211-33004	SIDE COVER	2
12.		WZ-0430390-KP	WASHER	2

## 2. MAIN SHAFT COMPONENTS

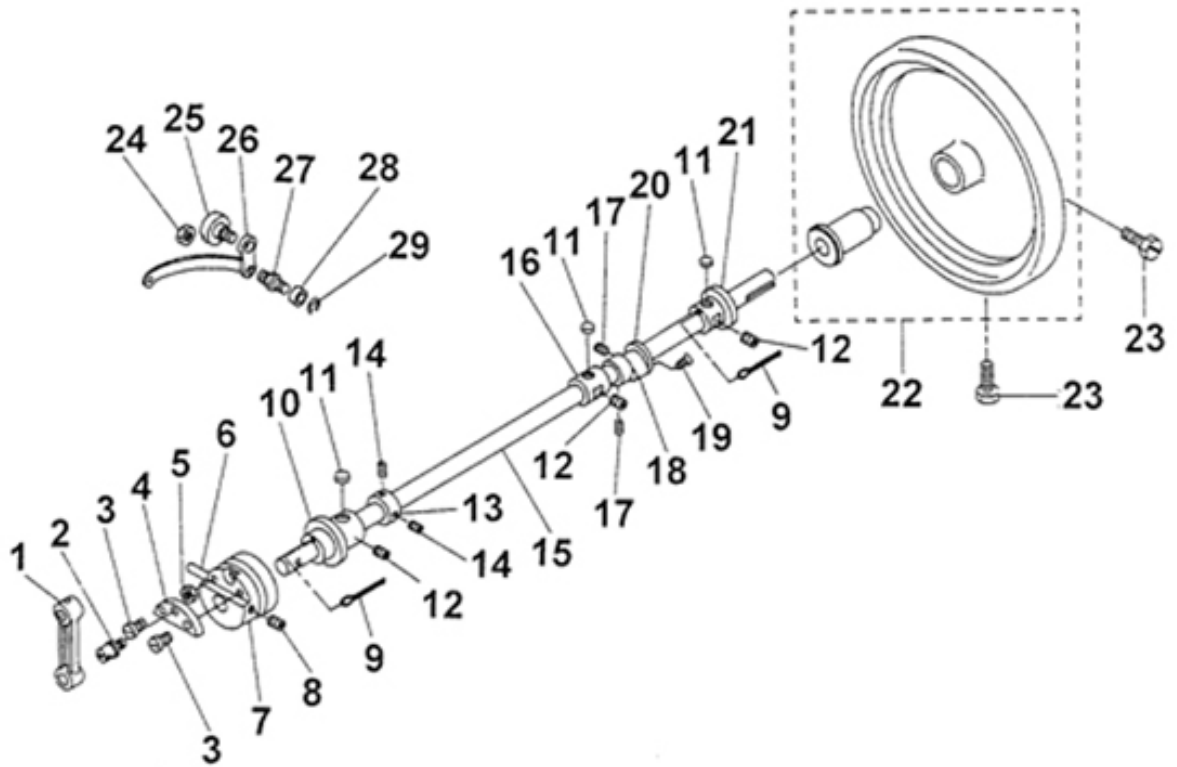

REF. NO.	NOTE	PART NO.	DESCRIPTION	ANT.
1.		210-91707	CRANK ROD	1
2.		210-45604	NEEDLE BAR CRANK SHAFT	1
3.		SS-1681140-SP	SCREW 9/32-28 L=11	2
4.		210-45109	CRANK PLATE	1
5.		NS-6680410-SP	NUT 9/32-28	1
6.		PT-0405600-SH	TAPER PIN	1
7.		210-44904	THREAD TAKE-UP CAM	1
8.		SS-8660612-TP	SCREW 1/4-40 L=6.0	2
9.		CQ-2020000-00	OIL WICK	0.2
10.		210-44607	MAIN SHAFT BUSHING, FRONT	1
11.		210-45406	FELT	3
12.		SS-8151550-SP	SCREW 15/64-28 L=15	3
13.		210-45703	THRUST COLLAR	1
14.		SS-8660610-TP	SCREW 1/4-40 L=6	2
15.		210-44508	MAIN SHAFT	1
16.		210-44706	MAIN SHAFT BUSHING, CENTER	1
17.		SS-8150710-SP	SCREW 15/64-28 L=7	2
18.		211-51402	FEED CAN	1
19.		SS-2110915-SP	SCREW 11/64-40 L=6.8	2
20.		210-45505	SIDE PLATE	1
21.		210-44805	MAIN SHAFT BUSHING, REAR	1
22.		210-40555	HEND WHEEL ASN.	1
23.		SS-9702110-SP	SCREW	2
24.		NS-6680410-SP	NUT 9/32-28	1
25.		SD-1070901-TP	HINGE SCREW	1
26.		210-91806	THREAD TAKE-UP LEVER	1
27.		210-46305	ROLLER STUD	1
28.		105-19502	ROLLER	1
29.		RE-0400000-KO	E-RING	1

### 3. NEEDLE BAR & UPPER FEED MECHANISM COMPONENTS

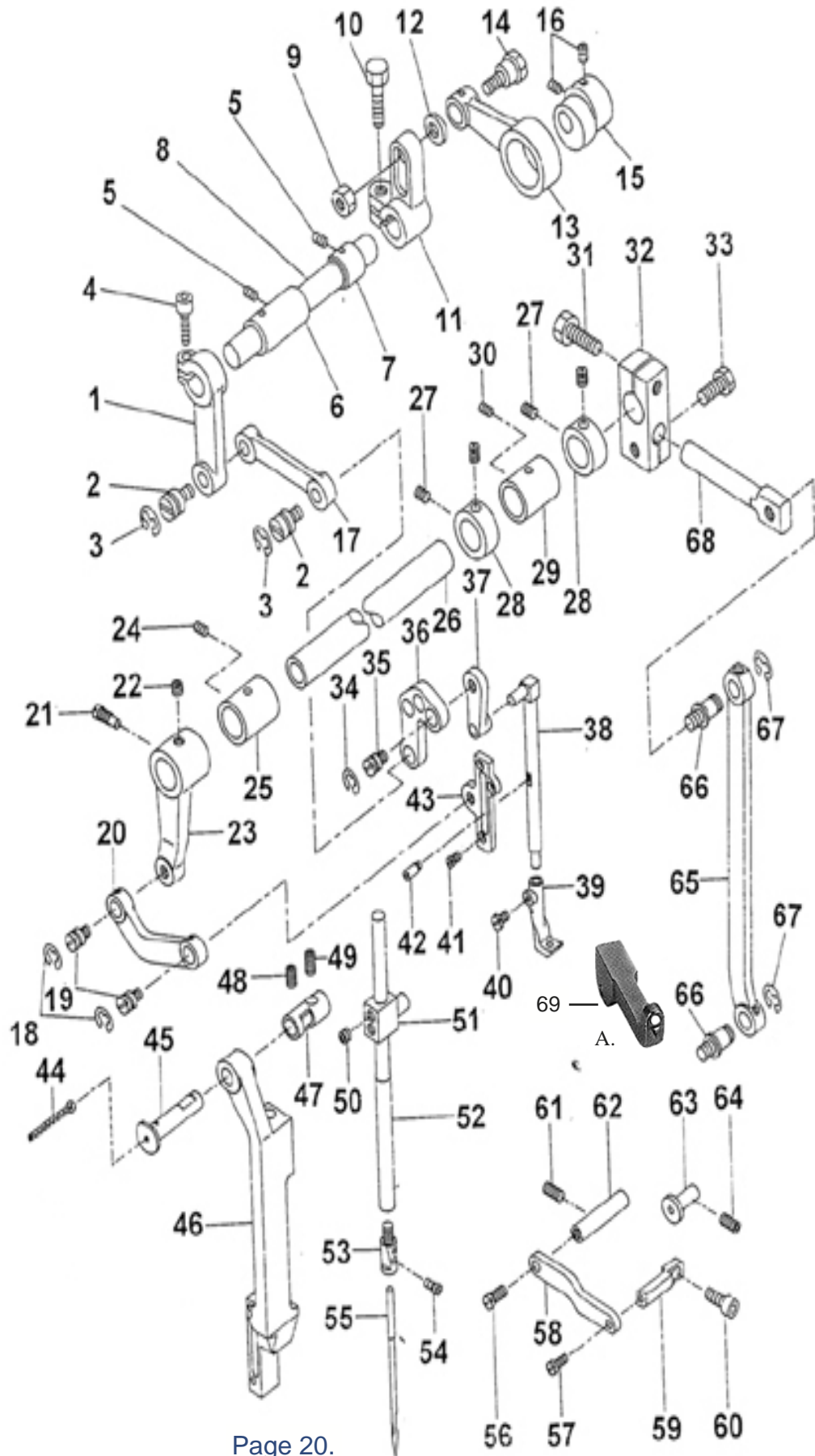



REF. NO.	PART NO.	DESCRIPTION	ANT.
1	210-49408	DRIVING SHAFT ARM FRONT	1
2	210-48707	HINGE SCREW	2
3	RE-0800000-00	E-RING	2
4	SM-6061552-TP	SCREW M6 L-15	1
5	SS-8150710-SP	SCREW 15/64.28 l=7	2
6	210-49705	BUSHING, FRONT	1
7	210-49804	BUSHING, REAR	1
8	210-49606	FEED ROCKER SHAFT	1
9	NS-6720440-SP	NUT 11/32-28	1
10	SS-9201813-CP	SCREW 5/46-18 l=18	1
11	210-49507	DRIVING SHAFT ARM, FRONT	1
12	210-50109	WASHER	1
13	210-49309	CONNECTING ROD	1
14	210-50000	HINGE SCREW	1
15	210-49200	DRIVING CAM	1
16	SS-8660610-TP	SCREW 1/4-40 L=6	2
17	210-49903	ROD	1
18	RE-0800000-KO	E-RING	2
19	210-48707	HINGE SCREW	2
20	210-93000	FRAME DRIVING LINE	1
21	SS-7151550-SP	SCREW 15/64-28 L=14.5	1
22	SS-8660512-TP	SCREW 1/4-40 L=5	1
23	210-92804	DRIVING SHAFT FRONT ARM	1
24	SS-8150710-SP	SCREW 15/64-28 L-7	1
25	210-92606	DRIVING SHAFT FRONT METAL	1
26	210-92507	DRIVING SHAFT	1
27	SS-8660810-TP	SCREW	4
28	CS-1801211-SH	THRUST COLLAR D-18 M-12	2
29	210-92705	DRIVING SHAFT REAR METAL	1
30	SS-8150710-SP	SCREW 15/64-28 l=7	1
31	SS-9202443-CP	SCREW 5/16-18 L=24	1
32	211-61609	DRIVING SHAFT REAR ARM A	1
33	SS-9201813-CP	SCREW 5/16-18 L=18	1
34	RE-0800000-KO	E-RING	2
35	210-48707	HINGE SCREW	2
36	210-93901	L LINK	1
37	210-94008	UPPER FEED FRAME DRIVING LINK	1
38	210-94701	UPPER FEED BAR	1
39	210-94107	PRESSURE FOOT	1
40	SS-7110840-SP	SCREW 11/64-40 L=7, 8	1
41	SS-7110540-SP	SCREW 11/64-40 L=5	3
42	210-94800	UPPER FEED BAR PIN	1
43	210-94909	UPPER FEED BAR GUIDE	1
44	CQ-2020000-00	OIL WICK	1
45	210-91406	FRAME DRIVING BASE SHAFT	1
46	210-92101	FRAME DRIVING BASE	1
47	210-93505	FRAME DRIVING BASE SHAFT METAL	1
48	D2446-141 E00	METAL SCREW	1
49	SM-8061212-TP	SCREW M6X12	1
50	SS-8660522-TP	SCREW 1/4-40 L=4.5	2
51	210-92309	NEEDLE BAR CONNECTION	1
52	210-92002	NEEDLE BAR	1
53	210-92408	NEEDLE STOPPER	1
54	SS-6110710-TP	SCREW 11/64-40 L=6.5	1
55	MC-5320023-00	NEEDLE (7794- NM=230)	1
56	SS-7151120-SP	SCREW 15/64-28 L=11	1
57	SS-7111120-SP	SCREW 11/64-40 L=10.5	1
58	210-92200	PRESSURE PLATE	1
59	210-93208	PRESSURE PLATE	1
60	SM-6061552-TP	SCREW M6 L=15	1
61	SM-8061212-TP	SCREW M6X12	1
62	210-93307	PRESSURE SHAFT	1
63	210-93604	FRAME DRIVING BASE GUIDE	1
64	SM-8061212-TP	SCREW M6X12	1
65	211-61807	FRAME DRIVING ROD	1
66	B1424-158-000	HINGE SCREW	2
67	RE-0700000-KO	E-SHAPED SNAP RING (704)	2
68	211-61708	DRIVING SHAFT REAR ARM B	1
69	43423	INSIDE LEATHER STITCHING PRESSER FOOT	1

#### 4. PRESSER BAR COMPONENTS

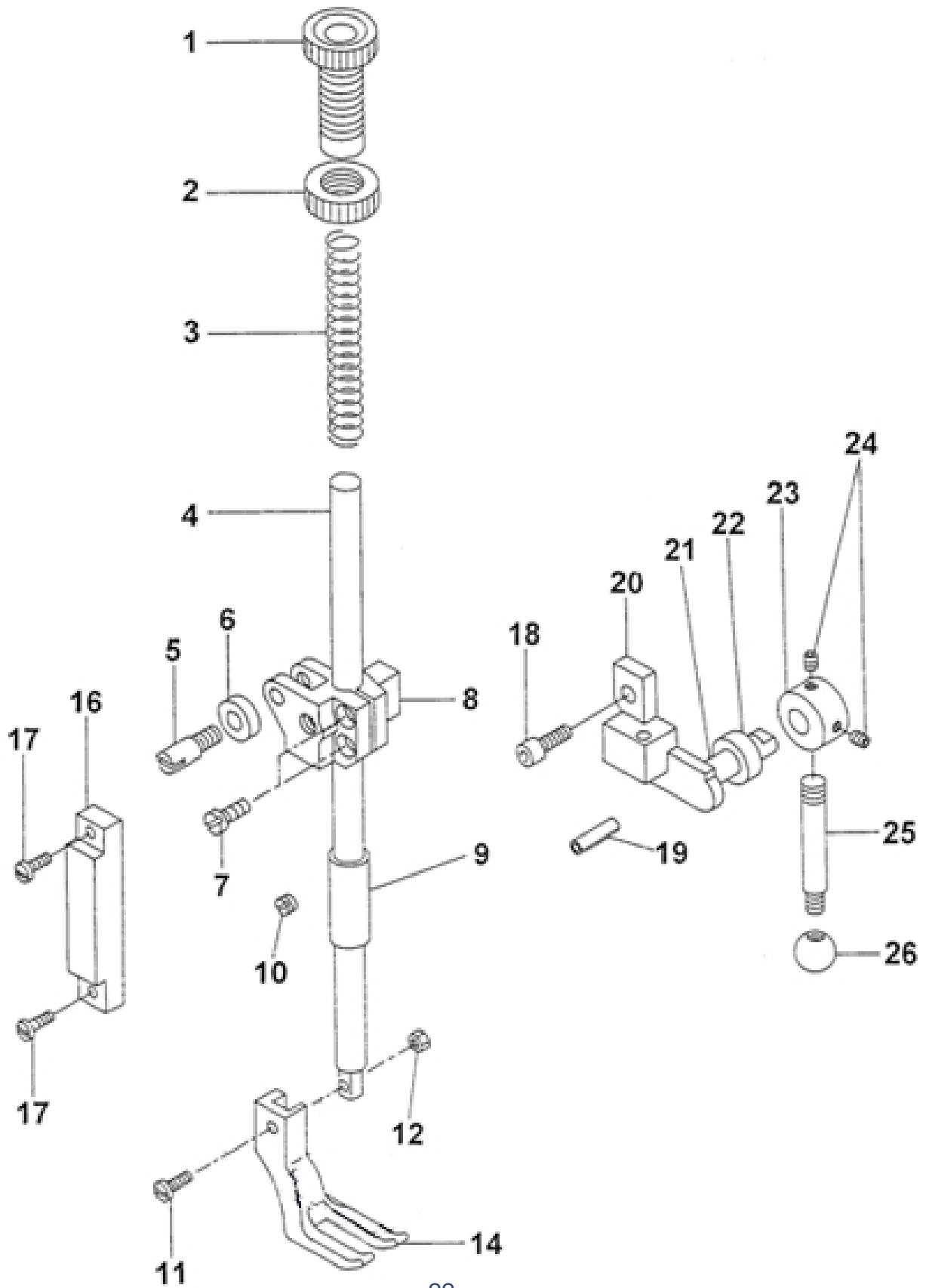

REF. NO.	PART NO.	DESCRIPTION	ANT.
1.	210-50703	SCREW	1
2.	210-51305	NUT	1
3.	210-50802	SPRING	1
4.	210-50505	PRESSER BAR	1
5.	210-51800	GUIDE NUT	1
6.	210-51701	ROLLER FOLLOWER	1
7.	SS-6121210-SP	SCREW 3/16-28 L=12	2
8.	210-95005	PRESSURE BAR	1
9.	210-50604	PRESSER BAR BUSHING	1
10.	SS-8150410-SP	SCREW 15/64-28 L=4	1
11.	SS-7091410-SP	SCREW 9/64-40 L=13.5	1
12.	NS-6090310-SP	NUT 9/64-40	1
14.	210-95104	OUTSIDE PRESSER FOOT WITH TEETH FOR FABRICS	1
16.	210-51503	GUIDE PLATE	1
17.	SS-7621040-SP	SCREW 3/16-32 L=9.5	2
18.	SS-6660622-TP	SCREW	1
19.	PS-0300201-KP	SPRING PIN 3.0X20	1
20.	210-51008	HAND LIFTER LINK	1
21.	210-51107	HAND LIFTER CAM	1
22.	B1662-562-000	COLLAR	1
23.	210-51602	THRUST COLLAR	1
24.	SS-8660522-TP	SCREW 1/4-40 L=4.5	2
25.	210-51206	HAND LIFTER LEVER	1
26.	210-51404	GRIP	1

- A. 43423 Center Grover Leather Presser Foot
- B. 43424 Left Side Leather Presser Foot
- C. 43425 Right Side Leather Presser Foot
- D. 43426 Double Toe Leather Presser Foot
- E. 43405 Double Toe Presser Foot with Teeth for Fabric or Webbing (aka Blanket)
- F. 43406 Center Presser Foot with Teeth for Fabric or Webbing (aka Blanket)
- G. 43424S Short Toe, Left Side Leather Presser Foot
- H. 43425S Short Toe, Right Side Leather Presser Foot

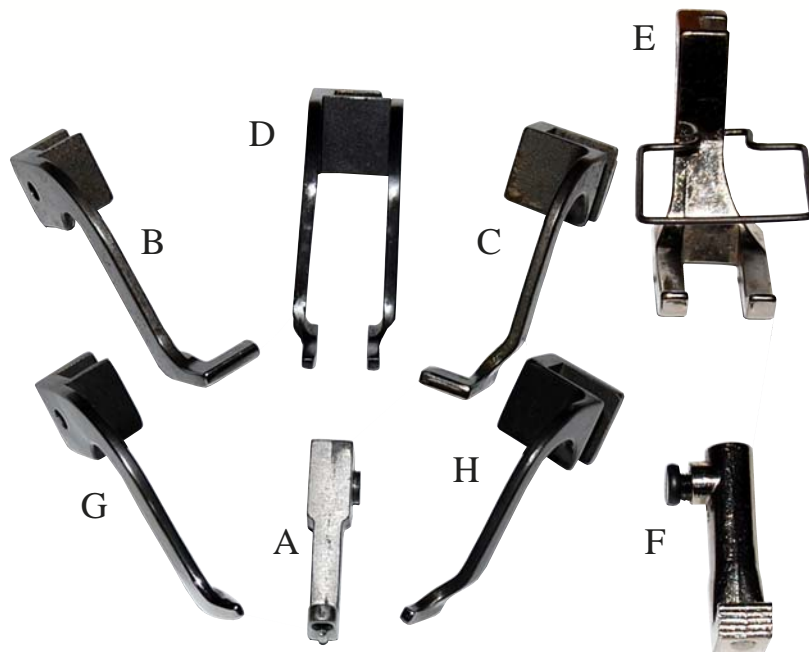

# 5. FEED MECHANISM COMPONENTS

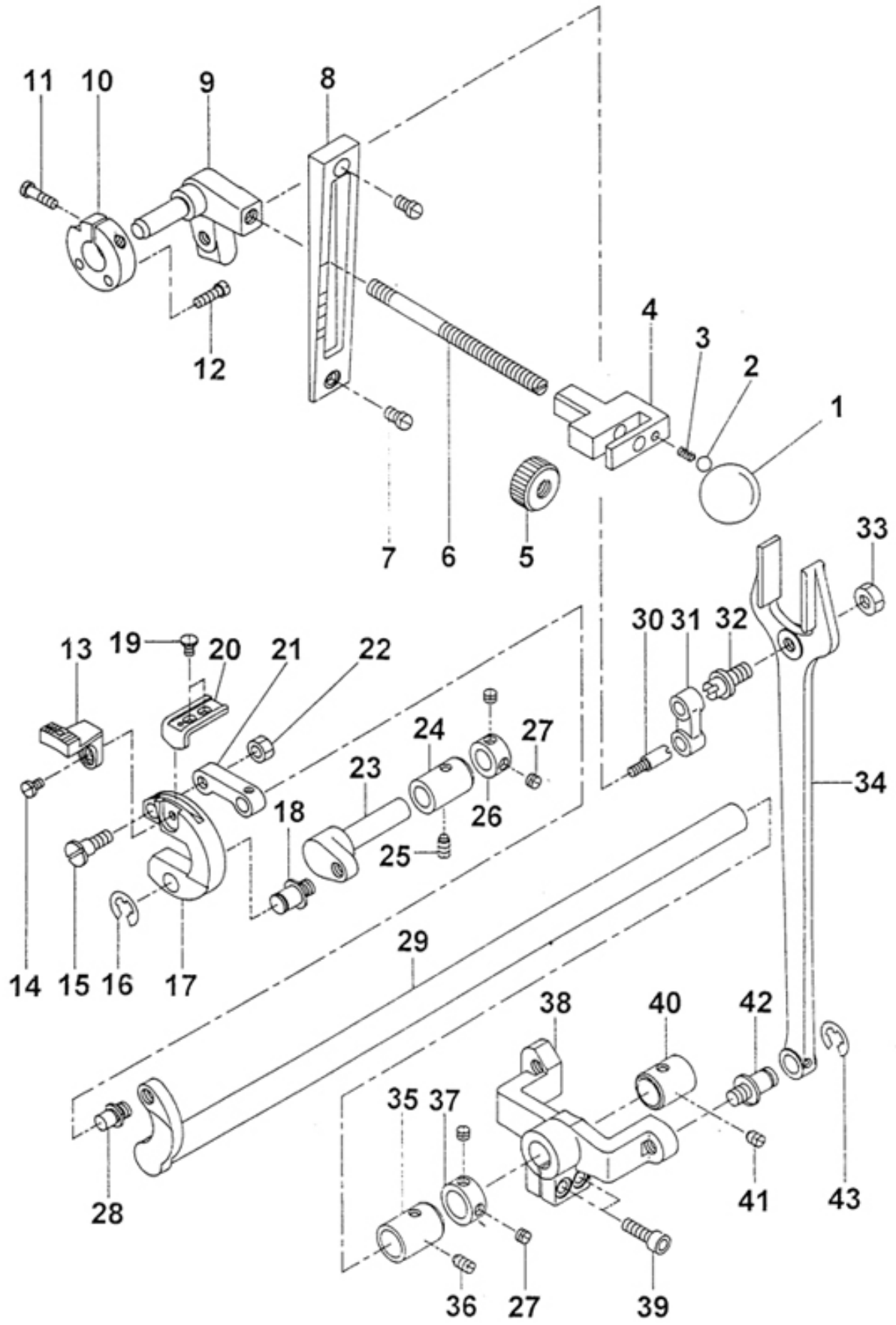



5. NO.	NOTE	PART NO.	DESCRIPTION	ANT.
1.		210-54507	LEVER GRIP	1
2.		210-54903	BALL	1
3.		210-54804	SPRING	1
4.		210-54606	LEVER	1
5.		210-54705	NUT	1
6.		210-54408	LEVER SHAFT	1
7.		SS-7150940-SP	SCREW 15/64-28 L=9	2
8.		211-52905	SIDE COVER	1
9.		211-52806	FEED REGULATOR	1
10.		211-53903	SUPPORT PLATE	1
11.		SS-6621840-SP	SCREW 3/16-32 L=18.0	1
12.		SS-6121210-SP	SCREW 3/16-28 L=15.5	2
13.		211-62300	FEED DOGK	1
14.		SS-7110840-SP	SCREW 11/64-40 L=7.8	1
15.		SD-0790801-SP	HINGE SCREW D=7.94 H=8	1
16.		RE-0800000-KO	E-RING	1
17.		211-51907	FEED BAR	1
18.		210-26901	HINGE SCREW	1
19.		SS-6110610-TP	SCREW 11/64-40 L=6	2
20.		211-53705	FEED BAR PRESSURE	1
21.		211-52004	FEED BAR LINK	1
22.		NS-6160520-SP	NUT 1/4-24	1
23.		211-52103	DRIVING SHAFT	1
24.		211-53606	DRIVING SHAFT MEAL	1
25.		SS-8151150-SP	SCREW 15/64-28 10.5	1
26.		CS-1111019-SH	THRUST COLLAR D=11.11 W=10	1
27.		SS-8660330-SP	SCREW 1/4-40 L=3.0	4
28.		211-53804	HINGE SCREW	1
29.		211-52251	FEED ROCKER SHAFT ASM.	1
30.		B1617-241-H00	HINGE SCREW, A	1
31.		B1619-241-H00	FEED CONNECTING LINK	1
32.		B1618-241-H00	HINGE SCREW, B	1
33.		NS-6680410-SP	NUT 9/32-28	1
34.		211-52707	ROD	1
35.		211-52400	BUSHING, FRONT	1
36.		SS-8151150-SP	SCREW 15/64-28 L=10.5	1
37.		CS-1471012-SH	THRUST COLLAR D=14.72 W=10	1
38.		211-62003	FEED ROCK SHAFT CRANK	1
39.		SM-6061802-TP	SCREW M6 L=18	2
40.		211-52509	BUSHING, REAR	1
41.		SS-8150750-SP	SCREW 15/64-28 L=7	1
42.		B1424-158-000	HINGE SCREW	1
43.		RE-0700000-KO	E-SHAPED SNAP RING (7MM)	1

## 6. Hook Driving Shaft Components

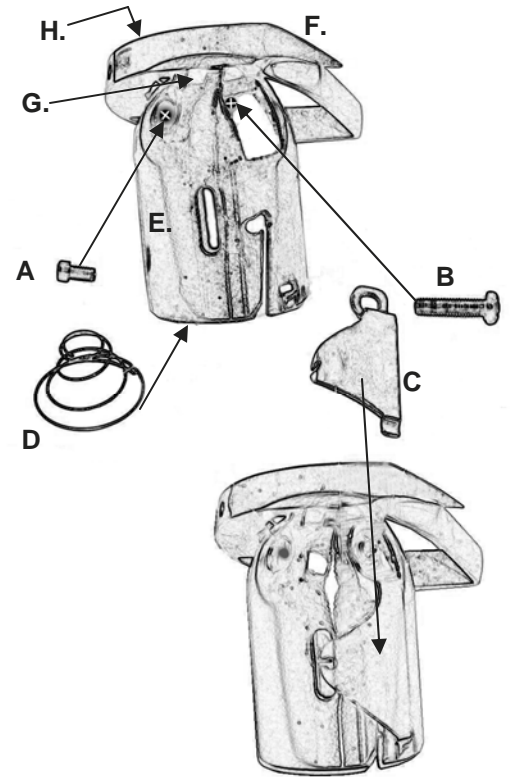
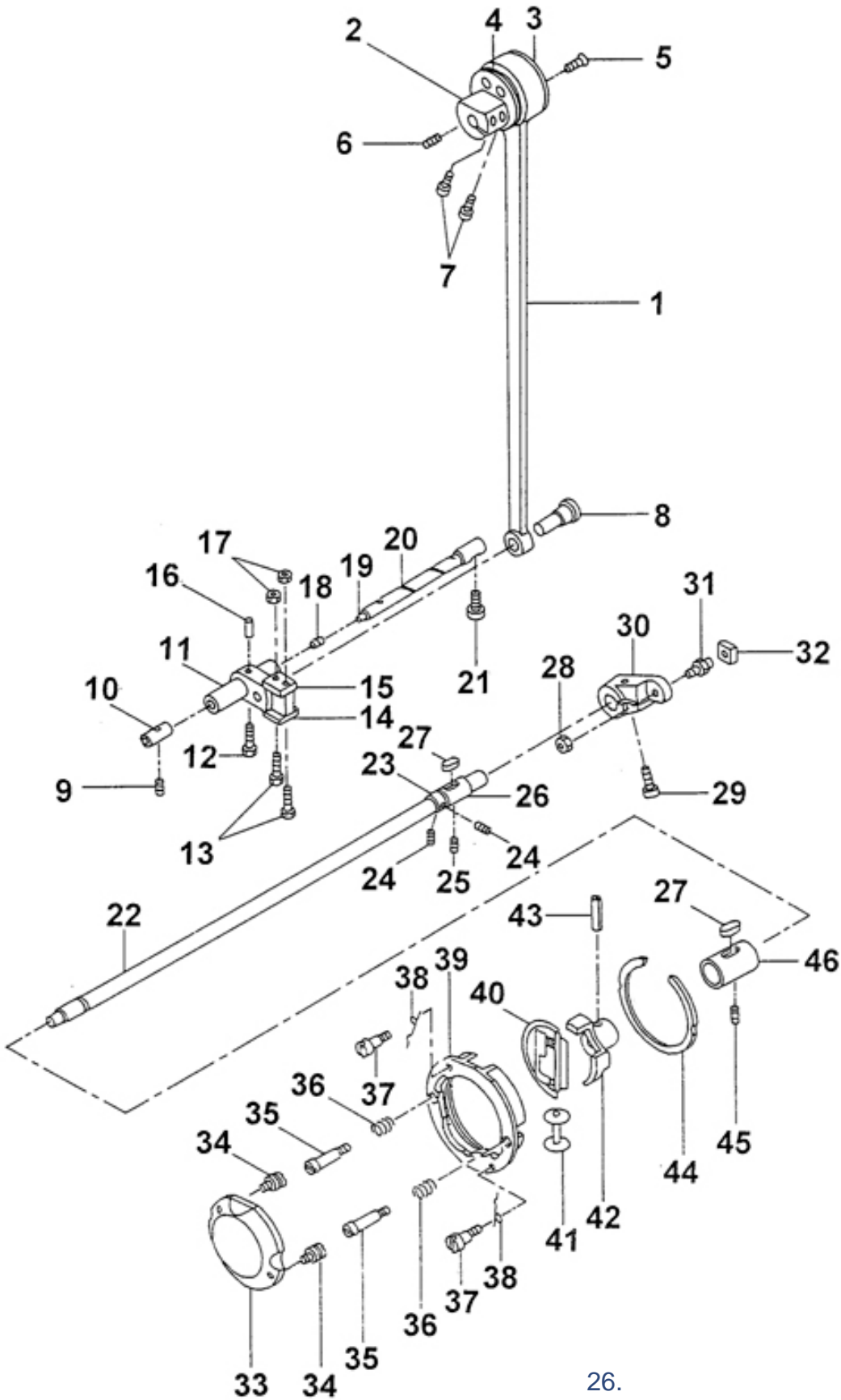

### Shuttle Hook Parts

- A. GS 184  
Locking Set Screw.
- B. GS 164  
Thread Tension Adjusting  
Screw.
- C. GW 113  
Thread Tension Spring.
- D. GW 114  
Bobbin Push-out Spring.
- E. GN 115  
Bobbin Case Body.
- F. GN 112  
Shuttle Body.
- G. GW 112  
Bobbin Case Opening Spring.
- H. GN 114  
Bobbin Case Body  
Latch.
- I. GS 120  
Bobbin Case Body Latch  
Screw.

6.

REF. NO.	PART NO.	DESCRIPTION	ANT.
1.	210-55504	CONNECTING ROD	1
2.	210-55603	CON-ROD ECCENTRIC CAM	1
3.	210-55702	CAM SLIDE PLATE	1
4.	210-57609	CAGE & ROLLER	1
5.	SS-2110920-TP	SCREW 11/64-40 L=8.5	2
6.	SS-8151550-SP	SCREW 15/64-28 L=15	1
7.	SM-6081802-TP	SCREW	2
8.	210-57203	CON-ROD PIN	1
9.	SS-8150750-SP	SCREW 15/64-28 L=7	1
10.	211-54109	ROCK SHAFT BUSHING	1
11.	210-55801	OSCILATING ROCK SHAFT	1
12.	SS-7621510-SP	SCREW	1
13.	210-57708	SCREW	2
14.	210-57005	SLIDE PLATE A	1
15.	210-57104	SLIDE PLATE B	1
16.	210-57302	CON-ROD PIN WEDGE	1
17.	NS-6110420-SP	NUT 11/64-40	2
18.	TA-0290301-MO	PLUG 2.9X3.2X3	1
19.	CQ-3030000-00	OIL WICK	1
20.	211-54000	HINGE SCREW	1
21.	SS-6151142-TP	SCREW 15/64-28 L=10.5	1
22.	211-54307	HOOK CRIVING SHAFT	1
23.	CS-1471012-SH	THRUST COLLAR D=14.72 W=10	1
24.	SS-8660330-SP	SCREW 1/4-40 L=3.0	2
25.	SS-8151550-SP	SCREW 15/64-28 L=15	1
26.	211-54505	DRIVING SHAFT BUSHING, REAR	1
27.	B1806-038-000	OIL FELT	2
28.	NS-6680320-SP	NUT 9/32-28	1
29.	SM-6081802-TP	SCREW	1
30.	211-54208	HOOK DRIVING SHAFT CRANK	1
31.	210-56304	SLIDE BROCK STUD	1
32.	210-56205	CRANK SLIDE BLOCK	1
33.	211-54802	HOOK COVER	1
34.	211-55007	HOOK COVER SCREW	2
35.	210-57906	SCREW	2
36.	210-57500	HOOK COUNTER SPRING	2
37.	SD-0260271-SP	HINGE SCREW D=2.60 H=2.7	2
38.	211-54901	HOOK COVER SPRING	2
39.	211-54703	SHUTTLE RACE BODY	1
40.	210-41850	OSCILLATING SHUTTLE HOOK	1
41.	210-57401	BOBBIN	1
42.	211-63001	SHUTTLE DRIVER	1
43.	PT-0401800-SO	TAPERED PIN 4.0X18	1
44.	211-55106	SPACER	1
45.	SS-8151550-SP	SCREW 15/64-28 L=15	1
46.	211-54406	DRIVING SHAFT BUSHING, FRONT	1

## 7. TENSION POST COMPONENTS

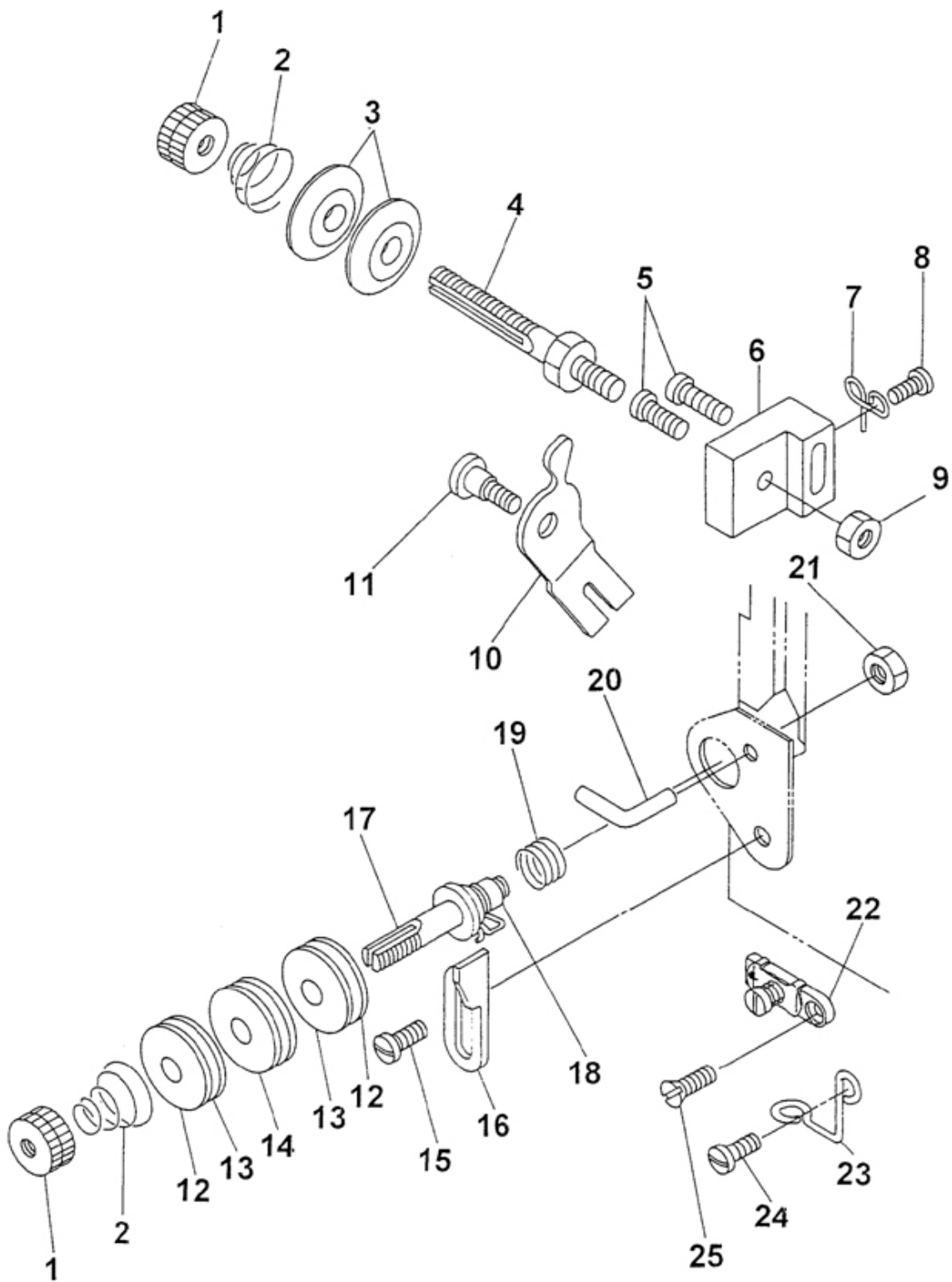



7.	REF.NO.	NOTE	PART NO.	DESCRIPTION	ANT.
	1.		B3125-012-000	THREAD TENSION STUD NUT	2
	2.		210-59100	THREAD TENSION SPRING	2
	3.		B3126-012-000	TENSION DISC	2
	4.		210-59001	THREAD TENSION POST	1
	5.		SS-7111120-SP	SCREW 11/64-40 L=10.5	2
	6.		210-59209	THREAD TENSION POST BRACKET	1
	7.		210-59308	THREAD TENSION GUIDE	1
	8.		SS-7090710-SP	SCREW 9/64-40 L=6.8	1
	9.		NS-6680320-SP	NUT 9/32-28	1
	10.		210-59407	THREAD RELEASING PLATE	1
	11.		SD-0600321-SP	HINGE SCREW D=6 H=3.2	1
	12.		210-60207	FELT SUPPORT PLATE	2
	13.		210-60108	WHEEL FELT	2
	14.		210-60009	THREAD TENSION WHEEL	1
	15.		SS-7090610-SP	SCREW 9/64-4 L=6	1
	16.		210-59803	SPRING SUPPORT PLATE	1
	17.		210-59902	THREAD TENSION WHEEL POST	1
	18.		210-59605	SPRING A	1
	19.		210-59704	THREAD TAKE-UP SPRING GUIDE	1
	20.		210-59506	SLACK THREAD GUIDE	1
	21.		NS-6150310-SP	NUT 15/64-28	1
	22.		D1129-141-EAO	ARM THREAD GUIDE BOTTOM ASM.	1
	23.		B1131-562-000	FRAME THREAD GUIDE, LOWER	1
	24.		SS-7090710-SP	SCREW 9/64-40 L=6.8	1
	25.		SS-1090410-SL	SCREW 9/64-40 L=4	1

# 8. BOBBIN WINDER AND THREAD GUIDE COMPONENTS

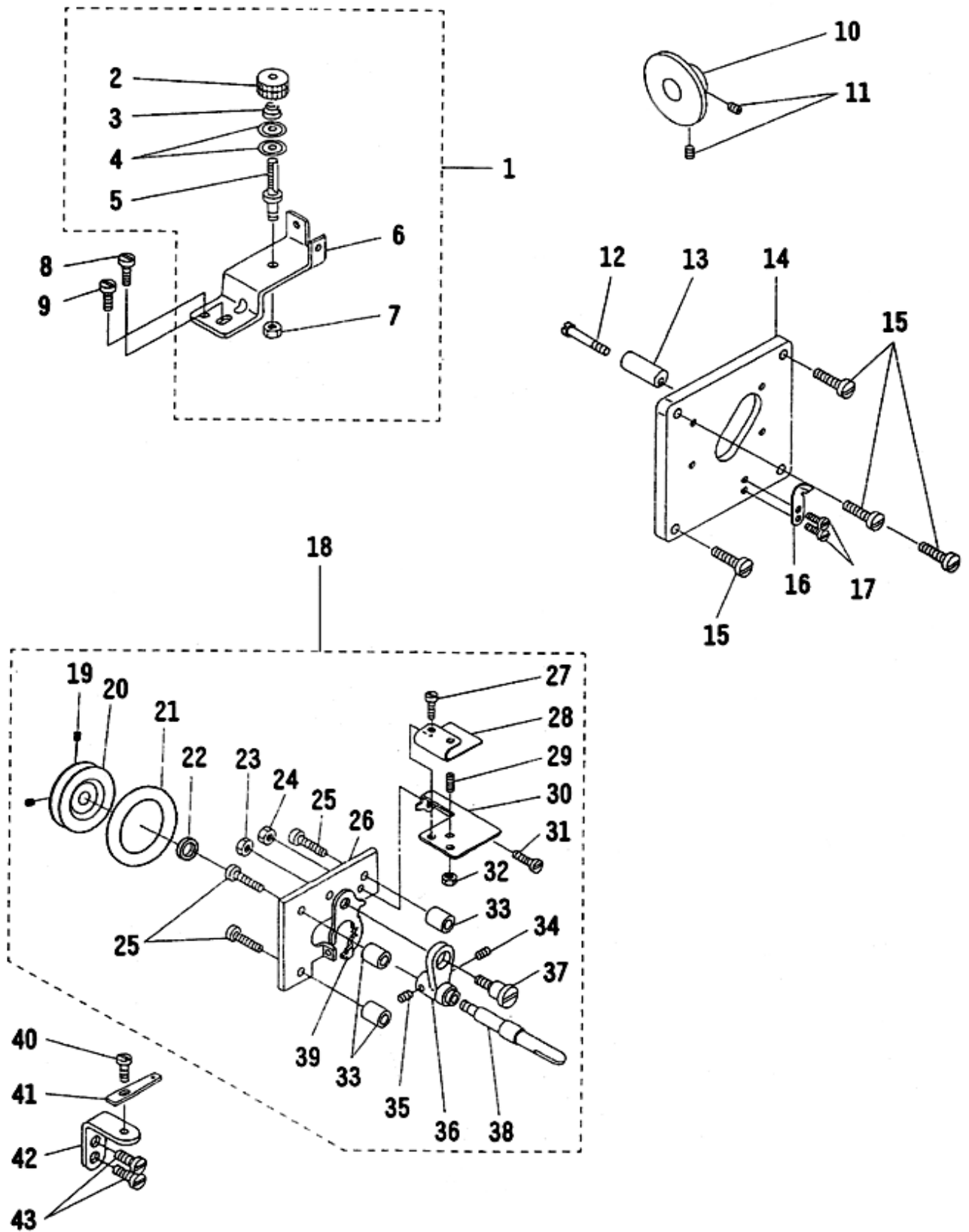

8.	REF.NO.	NOTE	PART NO.	DESCRIPTION	ANT.
	1.		210-61759	THREAD WINDER GUIDE BASE ASM.	1
	2.		B3125-012-000	THREAD TENSION STUD NUT	1
	3.		B3129-012-B00	TENSION SPPING B	1
	4.		B3126-012-000	TENSION DISC	2
	5.		210-59001	THREAD TENSION POST	1
	6.		210-61700	THREAD WINDER GUIDE	1
	7.		NS-6680320-SP	NUT 9/32-28	1
	8.		SS-7110910-SP	SCREW 11/64-40 L=8.5	1
	9.		SS-4080610-SP	SCREW 11/8-44 L=6.4	1
	10.		210-61601	FRICTION WHEEL	1
	11.		SS-8150710-SP	SCREW 15/64-28 L=7	2
	12.		SS-7112810-SP	SCREW 11/64-40 L=28	1
	13.		210-61403	STOPPER	1
	14.		210-42908	THREAD WINDER PLATE	1
	15.		SS-7111120-SP	SCREW 11/64-40 L=10.5	4
	16.		210-61502	THREAD CUT & CLAMP PLATE	1
	17.		SS-6080410-SP	SCREW 1/8-44 L=4	2
	18.		210-61056	THREAD WINDER ASM.	1
	19.		NS-6120310-SP	NUT 3/16-28	1
	20.		B3209-232-000	WASHER	2
	21.		B3203-232-000	BOBBIN WINDER WORM WHEEL	1
	22.		B3207-158-000	THREAD WINDING SHAFT COLLAR	1
	23.		NS-6110310-SP	NUT 11/64-40	1
	24.		NS-6110310-SP	NUT 11/64-40	1
	25.		SS-7111810-SP	SCREW 11/64-40 L=18	3
	26.		B3201-158-000	THREAD WINDER BASE	1
	27.		SS-5060410-SP	SCREW 3/32-56 L=3.5	2
	28.		210-61205	BOBBIN PRESSURE SPRING	1
	29.		D2443-141-E00	ADJUSTING SCREW	1
	30.		210-61106	BOBBIN PRESSER	1
	31.		SD-0720193-SP	HINGE SCREW D=7.24 H=1.9	1
	32.		NS-6080210-SP	NUT 1/8-44	1
	33.		B3203-158-000	WASHER	3
	34.		B3208-232-000	SPRING	1
	35.		A3222-958-000	BOBBIN WINDER SPPING, LONG	1
	36.		B3204-232-000	BOBBIN WINDER FRAME	1
	37.		B3205-232-000	HINGE SCREW,	1
	38.		210-61007	THREAD WINDER SHAFT	1
	39.		B3206-232-000	BOBBIN WINDER TENSION BRACKET	1
	40.		SS-7090710-SP	SCREW 9/64-40 L=6.8	1
	41.		B2510-158-000	THREAD WINDER THREAD GUIDE	1
	42.		210-61908	GUIDE BRACKET	1
	43.		SS-7151120-SP	SCREW 15/64-28 L=11	2

## 9. KNEE LIFTER COMPONENTS

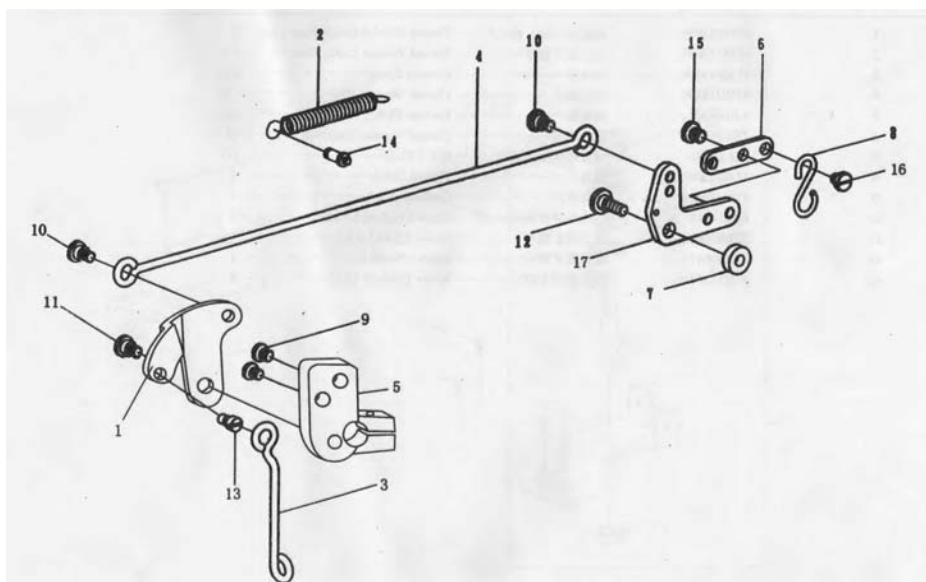

Ref No.	Part No.	DESCRIPTION	AMT.
1.	4710340100	Presser Bar Lifting Link	1
2.	B-1342-591-000	Presser Bar Lifting Return Spring	1
3.	210-62500	Presser Bar Lifting Bar	1
4.	211-56005-3000	Side Connecting Lever Bar	1
4b.	211-56005-3200	"	1
4c.	211-56005-4000	"	1
5.	4710340500	Adjustable Link Base	1
6.	211-56104	Link Plate	1
7.	181-25609	Link Collar Washer	1
8.	211-57607	"S" Hook	1
9.	SS-7150740-SP	Screw 15/64-28 L=7	2
10.	SD-0790431-SP	Shoulder Screw D=7.94 H=4.3	2
11.	SD-0790431-SP	"	1
12.	SD-0790432-SP	"	1
13.	210-62609	Hinge Screw	1
14.	B3413-227-000	Spring Mount Screw	1
15.	SS7150740-SP	Screw 15/64-28 L=7	1
16.	SD-0800341-SP	Hinge Screw D=7.94 H=4.3	1
17.	210-62807	Presser Bar Lifting Link	1

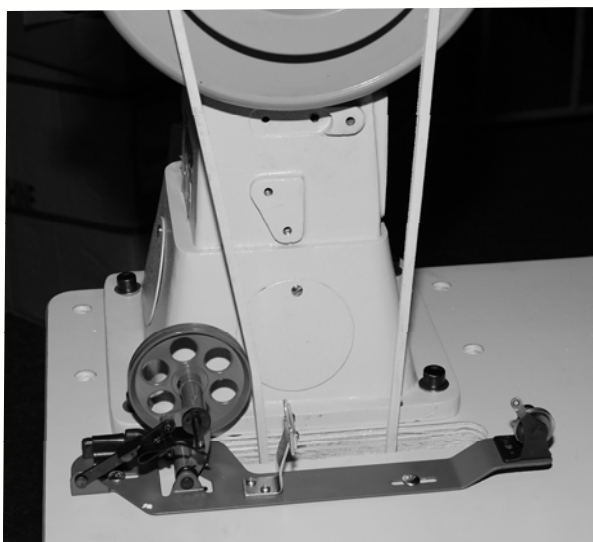

### TORO-3000 Bobbin Winder Instructions:

- Place the bobbin on the spindle. Align the small pin on the spindle with the hole or slot in the bobbin.
- Insert the thread into the eye above the bobbin winder tension.
- Pull the thread between the two tension discs in a clockwise fashion.
- Continue pulling the thread over to the bobbin and place the thread through the small hole on the right side of the bobbin and thread it from the inside of the bobbin to the outside of the bobbin.  
Leave about 3 or 4 inches outside the bobbin. Trim the excess after the bobbin is wound.
- Push the Latch up against the center of the bobbin.
- Operate the machine and the bobbin will begin to fill.  
Several bobbins can be wound while the machine is in operation.

If the thread is wound too loosely, tighten the tension nut,  
if too tight, loosen the nut.





for Artisan BT machines:  
 Remove Allen head screws  
 from presser bar lifting link,  
 Install the Lifting Handle  
 and reinsert screws.  
 Tighten screws securely.

Installation:  
 Presser Foot Lifting Handle  
 TORO-3200 BT

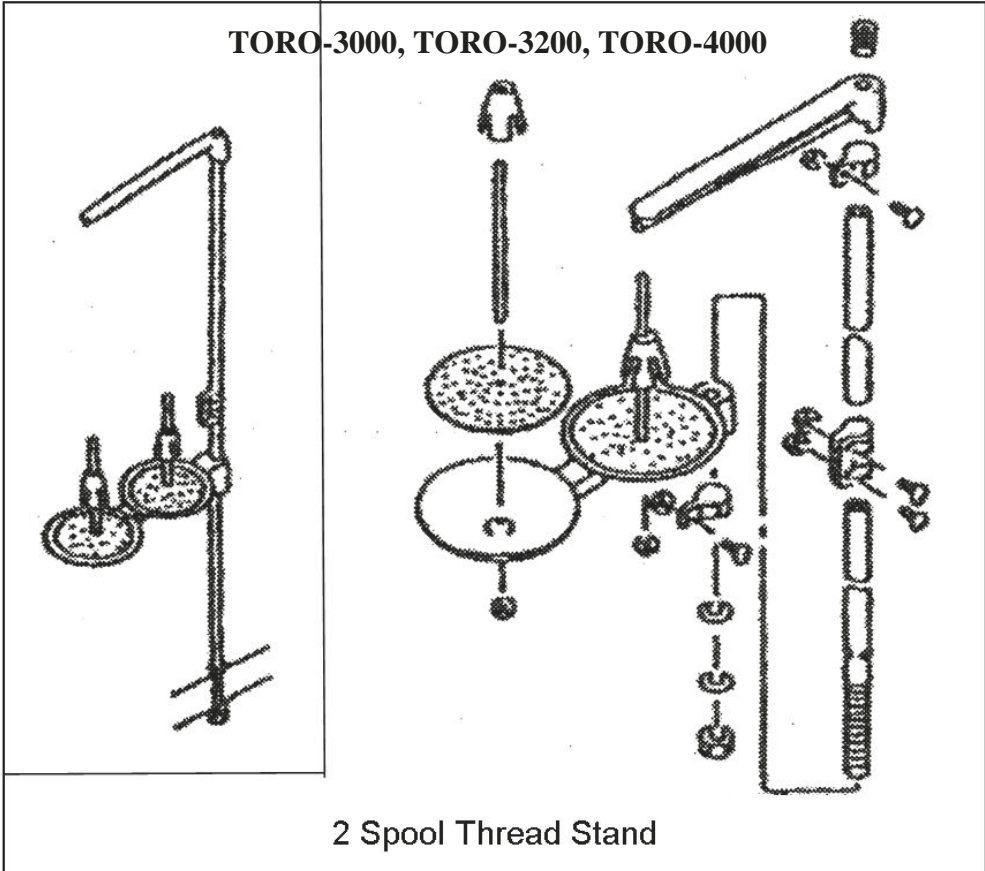



# ARTISAN®

TORO-3200 BT and TORO-4000 BT



# Thread Specifications

Mil Spec VT-295E

Sizes 15 to 92						
Commercial Size	<u>15</u>	<u>23</u>	<u>33</u>	<u>46</u>	<u>69</u>	<u>92</u>
Government Size	00	A	AA	B	E	F
Tex Size	T-16	T-24	T-30	T-45	T-70	T-90
<b>U.S.</b>						
Yards Per Pound	28,000	20,000	13,800	10,000	6,000	4,200
Tensile Strength (Pounds)	2	3	5	8	11	15
Diameter (Inches)	.0059	.0064	.0080	.0094	.0115	.0133
<b>Metric</b>						
Tensile Strength (Kilos)	0.9	1.4	2.3	3.6	5.0	6.8
Diameter (Millimeters)	0.1499	0.1626	0.2032	0.2388	0.2921	0.3378
Sizes 138 to 554						
Commercial Size	<u>138</u>	<u>207</u>	<u>277</u>	<u>346</u>	<u>415</u>	<u>554</u>
Government Size	FF	3 Cord	4 Cord	5 Cord	6 Cord	8 Cord
Tex Size	T-135	T-210	T-270	T-350	T410	T-600
<b>U.S.</b>						
Yards Per Pound	3,000	2,000	1,500	1,200	1,050	655
Tensile Strength (Pounds)	22	32	45	53	72	83
Diameter (Inches)	0,0163	0.0200	0.0231	0.0258	0.0283	0.0408
<b>Metric</b>						
Tensile Strength (Kilos)	10.0	14.5	20.4	24.0	32.7	37.6
Diameter (Millimeters)	0.4140	0.5080	0.5867	0.6553	0.7188	1.0358

## ARTISAN TORO-3000, 3200 and 4000 THREADING

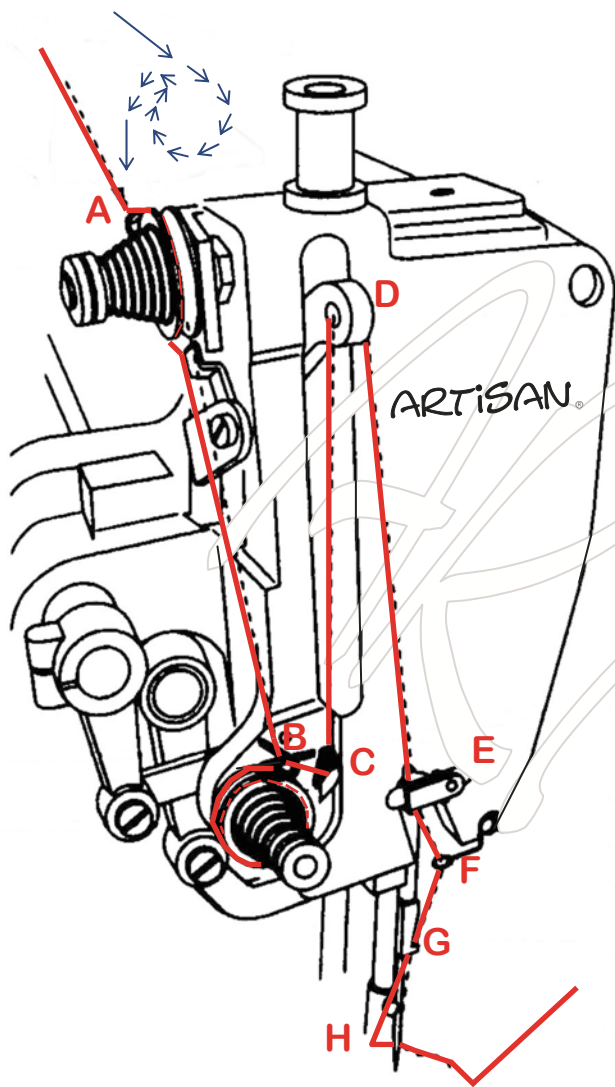

Insert the thread through the upper wire thread guide (A), then around the top tension (auxiliary tension) in a clockwise rotation between the 2 disks, one revolution and back up to the same wire thread guide (A).

Bring the thread down and insert it into the main tension thread guide (B) as shown. Then wind your thread in a counter-clockwise rotation 2 full revolutions around the main tension rotary disk, and then back up through the same thread guide (B) a second time.

Next pass the thread through the hole in the "check spring" (C). Then pull the thread up and pass it through the hole in the take-up lever (D) from the left side to right hand side. The lever moves up and down. Then pass the thread down and through the left side of lower middle thread guide (E).

Next pass the thread through the lower wire thread guide (F) and through the thread guide hole in the bottom of the needle bar (G).

Lastly pass the thread through the eye of the needle (H) from the left to to right side towards the hand wheel. Always leave about 6 to 10 inches of thread beyond the needle.

Remember to hold the bobbin and needle threads tightly while stitching the first few stitches.

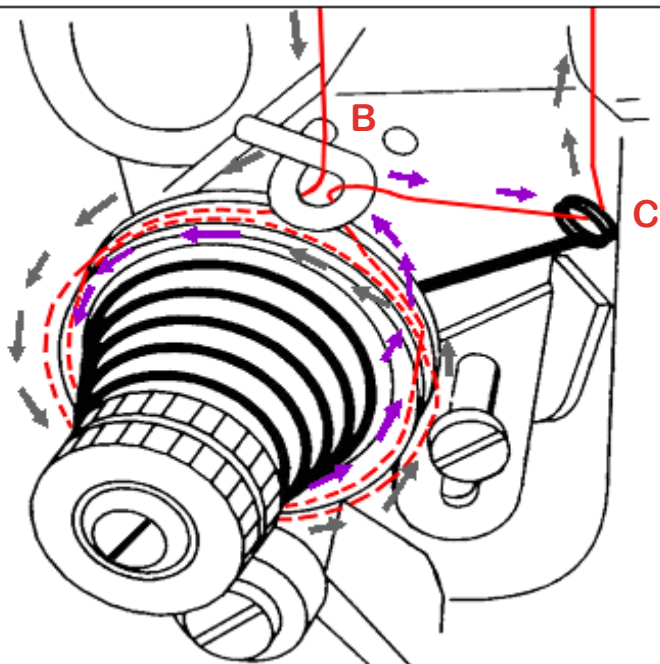

See Page 6 for Another View of Correct Threading Instructions