

# ARTISAN®

Model

# 2097-2 and 2097-3 Operators & Spare Parts Manuals

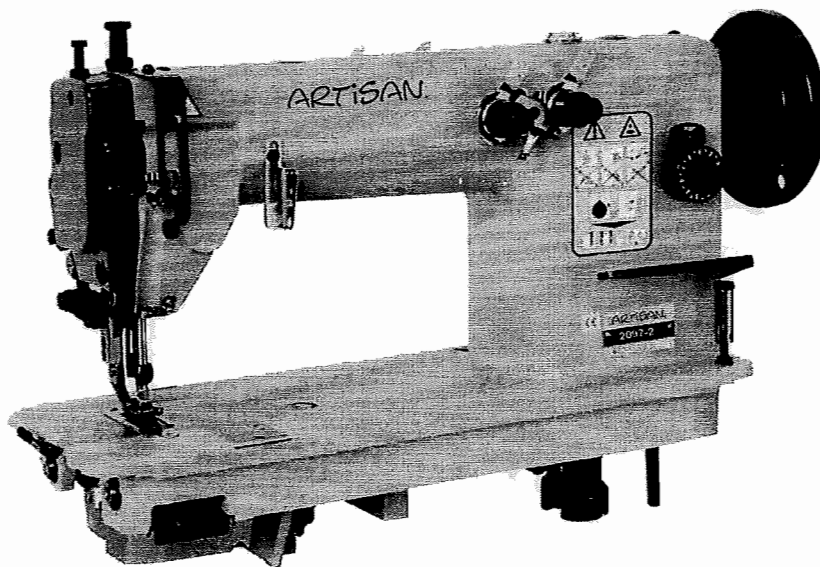

ARTISAN® SEWING SUPPLIES, INC

888 838 1408 toll free

323 838 1408 COMMERCE, CALIFORNIA USA fax 323 838 1508  
www.artisansew.com E-mail: info@artisansew.com

# CONTENTS

## OPERATION INSTRUTION

1. PRECAUTIONS BEFORE STARTING OPERATION.....	1
2. SPECIFICATIONS .....	1
3. INSTALLING THE MACHINE .....	2
4. OILING .....	2
5. THREADING NEEDLE THREAD .....	2
6. THREADING BOBBIN THREAD .....	3
7. THREAD TENSION.....	3
8. ADJUSTING THE PRESSURE OF PRESSER FOOT .....	3
9. ADJUSTING THE FEED MECHANISM .....	4
10. ADJUSTING THE ALTERNATING MOVEMENT .....	4
11. ADJUSTING THE STITCH LENGTH .....	4
12. INSTALLING THE NEEDLE .....	5
13. ADJUSTING THE HEIGHT OF PRESSER FOOT .....	5
14. ADJUSTING THE HEIGHT OF FEED DOG .....	5
15. TIMING OF FEED DOG AND NEEDLE .....	5
16. ADJUSTING THE HEIGHT OF NEEDLE BAR .....	6
17. ADJUSTING THE NEEDLE AND THE LOOPER .....	6
18. TIMING OF LOOPER AND NEEDLE .....	6
19. LOOPER TAKE-UP THREAD .....	6
20. CLEARANCE BETWEEN LOOPER AND NEEDLE .....	7
21. TIMING OF LOOPER GUARD .....	7
22. POSITION OF LOOPER GUARD .....	7
23. BOBBIN THREAD TAKE-UP CAM.....	7
24. THE POSITION OF THE THREAD-AMOUNT ADJUSTING PLATE OF THE THREAD TAKE-UP LEVER.....	8
25. THREAD GUIDE HOOK.....	8
26. CHANGING THE NEEDLE SPACE.....	8
27. MAINTAIN THE MACHINE .....	8
28. MEASURES OF COMMON TROUBLES .....	9

## PARTS CATALOG

A. ARM BED AND IT'S ACCESSORIES.....	11
B. ARM SHAFT AND NEEDLE BAR MECHANISM.....	13
C. PRESSER FOOT MECHANISM.....	15
D. FEEDING AND FEED LIFTING MECHANISM.....	17
E. STITCH REGULATOR MECHANISM.....	20
F. UPPER FEED LIFTING ROCK SHAFT MECHANISM.....	22
G. LOOPER MECHANISM.....	25
H. TAKE-UP THREAD TENSION AND RELEASE MECHANISM(1) .....	28
TAKE-UP THREAD TENSION AND RELEASE MECHANISM(2) .....	30
I. LUBRICATION MECHANISM .....	32
J. OIL PAN AND KNEE CONTROLMECHANISM.....	34
K. ACCESSORIES.....	36
L. SPECIAL PARTS FOR 2097-1 .....	38
M. SPECIAL PARTS FOR 2097-2 .....	40
PARTS FOR OTHER NEEDLE-SPACE.....	42

---

# 1. PRECAUTIONS BEFORE STARTING OPERATION

## 1) Safety precautions

(1) When turning the power on, keep your hands and fingers away from the area around/under the needle and the area around the pulley.

(2) Power must be turned off when the machine is not in use, or when the operator leaves the seat.

(3) Power must be turned off when tilting the machine head, installing or removing the “V” belt, adjusting the machine, or when replacing.

(4) Avoid placing fingers, hairs, bars etc., near the pulley, “V” belt, bobbin winder pulley, or motor when the machine is in operation.

(5) Do not insert fingers into the thread take-up cover, under/around the needle, or pulley when the machine is in operation.

(6) If a belt cover, finger guard, eye guard are installed, do not operate the machine without these safety devices.

## 2) Precautions before starting operation

(1) If the machine’s oil pan has an oil sump, never operate the machine before filling it.

(2) If the machine is lubricated by a drop oiler, never operate the machine before lubricating.

(3) When a new sewing machine is first turned on, verify the rotational direction of the pulley with the power on. (The pulley should rotate counterclockwise when viewed from the pulley).

(4) Verify the voltage and phase (single or three) with those given on the machine nameplate.

## 3) Precautions for operating conditions

(1) Avoid using the machine at abnormally high temperatures (35°C or higher) or low temperatures (5°C or lower) .

(2) Avoid using the machine in dusty conditions.

# 2. SPECIFICATIONS

MODEL	2097-1	2097-2	2097-3
MAX. SPEED (s. p. m. )	2500		
STITCH (mm)	1. 4-8		
MAX. LIFT OF FOOT (mm)	By hand 6, By knee 13		
NEEDLE	Schmetz: 149 x 5 #12 to 24 (80 to 180)		
LUBRICATION SYSTEM	Automatic		
THREAD TAKE-UP TYPE	Needle bar thread take up		
MOTOR	Artisan Electronic Servo		
NEEDLE SPACING (gauge)	6. 4, 7. 9, 9. 5, 12. 7	3. 2-3. 2, 6. 4-6. 4	

### 3. INSTALLING THE MACHINE (Fig.1)

Installing the oil reservoir:

Put the oil reservoir rubber cushion (1) and oil reservoir felt cushion (2) on four corners of the opening of the table, fix them with wood screws, then install the oil reservoir.

Installing the machine:

Put the machine connecting hooks into the holes to engage respectively two hinges seated in the table, then place the machine on the four cushions.

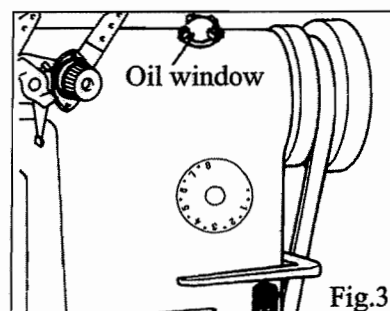
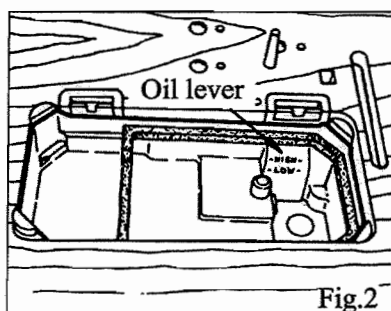
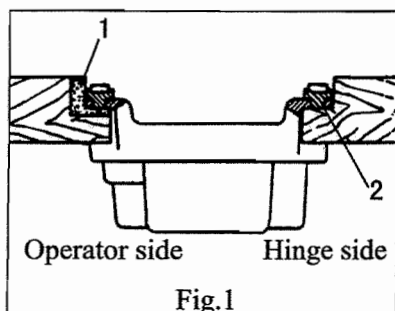

### 4. OILING (Figs.2, 3)

The machine should be oiled before starting operation. Oil should be in the lever "High". It should be oiled when the oil below the lever "Low". The normal condition of lubrication is that the oil spray onto the oil window. The amount of oil spray onto the oil window is no relation to the total amount of oil in the oil reservoir. Nothing to worry about. When change the oil, loosen the drain screw, the oil drain out then clean the oil reservoir and supply new oil. When operate new machine or after place for long time, presser foot shall be lifted and run idle in 1800-2000 s.p.m about ten minutes.

### 5. THREADING NEEDLE THREAD (Fig.4)

Pass the thread in the order as shown in Fig. 4 when the needle bar in high position. To make thread go through

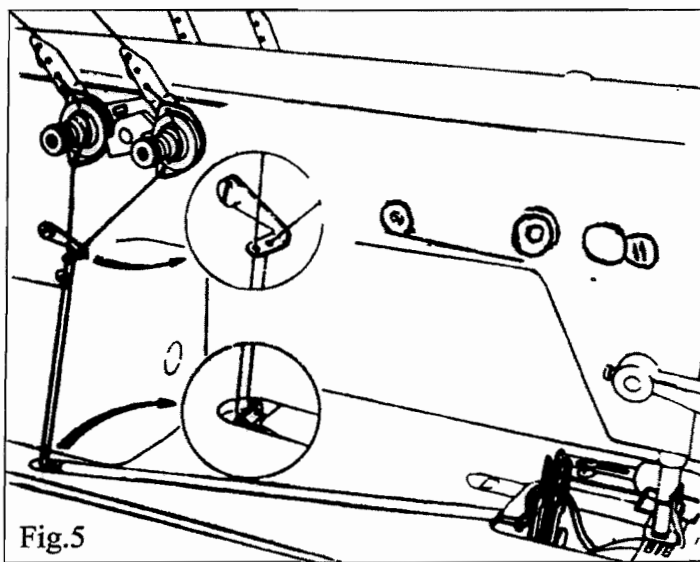
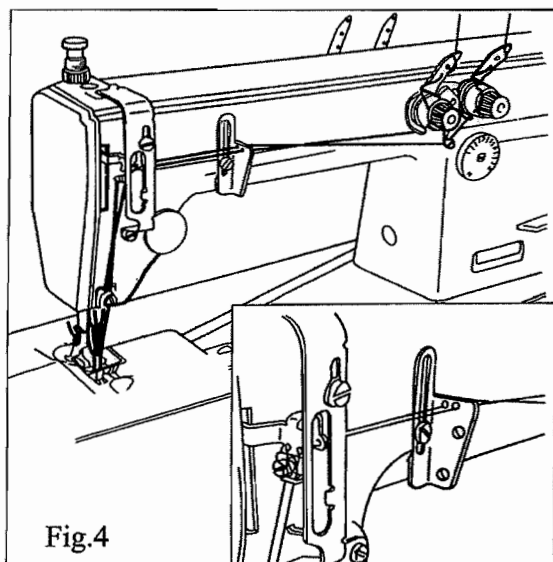

the eye of the needles outwards (view from the operator's side). To pull out 100mm of the remaining thread after needle thread going through the eye of the needles.

## 6. THREADING BOBBIN THREAD (Figs.5,6)

To make bobbin thread go through in the order as shown in(Figs. 5,6):

(1) Make the bobbin thread go through the needle tension regulator guide plate(single side);go through the two holes when thread of harder twist fiber is used or feed gauge is wider than usual.

(2) Pull the spring toward the operator,as shown in Fig.6 and part A will rise upwards.

(3) When threading the looper,the thread shall be made go through the eye of the needle with a tweezer as shown in Fig.6 and 50mm of remaining thread be pulled out.

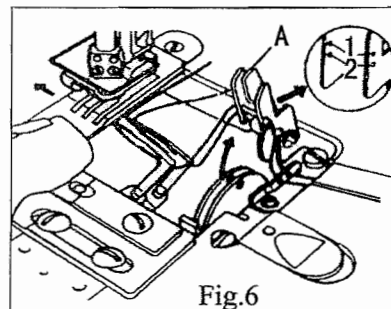

## 7. THREAD TENSION (Figs.7,8 and 9)

Needle thread tension is in accordance with sewing working condition,we can adjust needle thread tension by tension spring.Turn the tension nut clockwise to increase the tension;turn counter-clockwise to decrease the tension.

Bobbin thread tension is also in accordance with sewing working condition,we can adjust needle thread tension by tension spring.Turn tension screw clockwise to increase the tension;turn tension screw counter-clockwise to decrease the tension.The relation between the needle thread and the bobbin thread as shown in Fig. 9 depicts the forming of chain stitch.

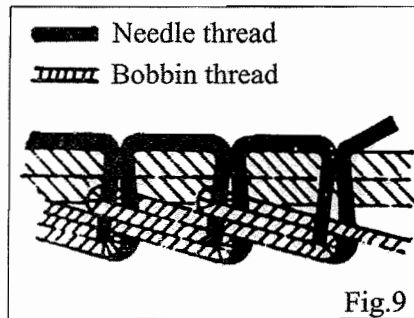
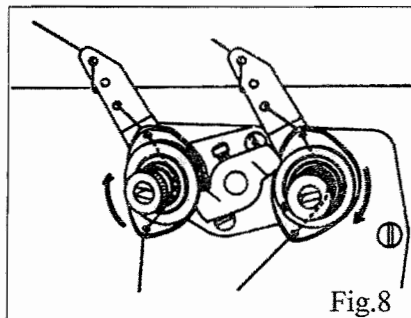
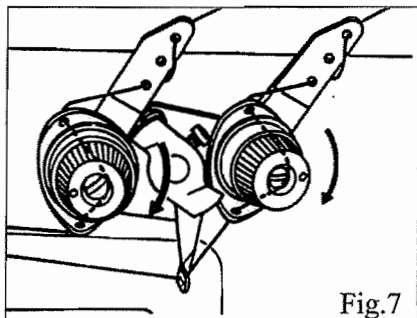

## 8. ADJUSTING THE PRESSURE OF PRESSER FOOT (Fig.10)

Pressure of the presser foot is to be adjusted in accordance with thickness of materials to be sewn.

First loosen Lock Nut(A).For heavy materials,turn the pressure regulating thumb screw as shown in Fig. 10 to increase the pressure,while for light materials,turn the pressure regulating thumb screw as shown in Fig. 10 to decrease the pressure.Then tighten Lock Nut(A).

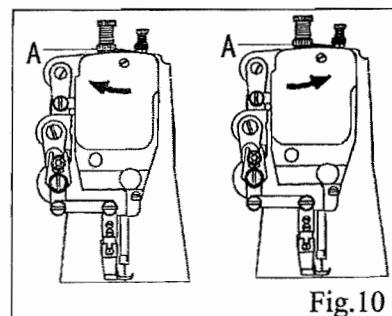

**The pressure of presser foot is recommended to be normal feeding.**

## 9. ADJUSTING THE FEED MECHANISM(Fig.11)

The top and bottom synchronised feeding is one important performance of all important performances. In practice, according to different friction of materials and the sewing craft, adjust the distance(L) between the lifting presser swing crank shaft and the presser swing shaft.

Adjustment method:

Increase L—the feeding quantity increase      Reduce L—the feeding quantity reduce

Regarding certain product special sewing request, if the top feeding quantity request is bigger than (or is smaller than) the bottom feeding quantity, also can be adjusted according to above principle.

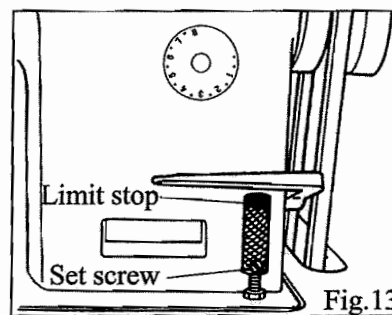
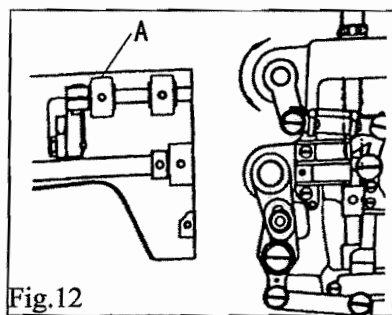
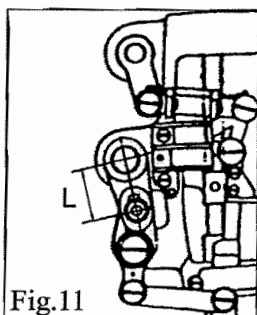

## 10. ADJUSTING THE ALTERNATING MOVEMENT(Fig.12)

In practice, according to different materials to be sewn. The alternating movement on the walking foot and the presser foot can be adjusted in certain range. According to the normal heavy material, the rise of the walking foot is below 3mm, the rise of the presser foot is about 2.5mm. When other mechanism is invariable, the sum of the walking foot and presser foot rise is also in constant. The regulation of the rise change in accordance with inverse ratio (the rise of walking foot increases, meanwhile the rise of the presser foot decreases). Otherwise also.

Adjustment method: loosen the screw(A) of the presser lifting shaft, turn the presser lifting crank as the Fig.12. Turn clockwise the rise of the walking foot increases and the rise of the presser foot decreases. Turn counter-clockwise the rise of the presser foot increases and the rise of the walking presser foot decreases. But the adjustment of the rise must be limited in a range. After adjustment tighten the screw(A), and turn the pulley by hand, use the machine after checking.

## 11. ADJUSTING THE STITCH LENGTH(Fig.13)

(1) To adjust the stitch length, turn the stitch dial to the number. The value of graduation is shown in millimeter (mm) .

(2) If need to change the stitch length, press down the reverse feed lever while turning the dial.

(3) Max. stitch length is 8mm; Min. stitch length is 1.4mm.

(4) When press down the reverse feed lever, the stitch become tight-needle stitch(1.4mm). This function often be used in beginning and seaming or reinforce sewing.

(5) **The machine can not reverse stitching.**

## 12. INSTALLING THE NEEDLE (Figs.14,15)

When the thread is chemical fibre thread, the direction of the needle eye should not be in that one, as shown in Fig.14(C).

2097 series machines are set up to use standard needle of 149 x 5 #12 TO 24. The size of needle to be used should be determined by the size of thread, type and thickness of the sewing materials.

Thread lubricants may be used when necessary. Fig. 15

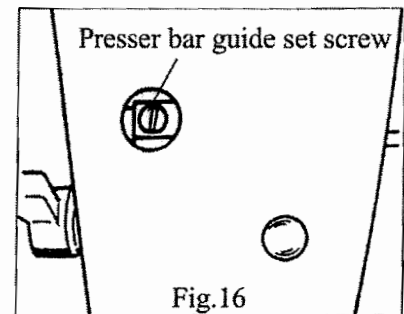
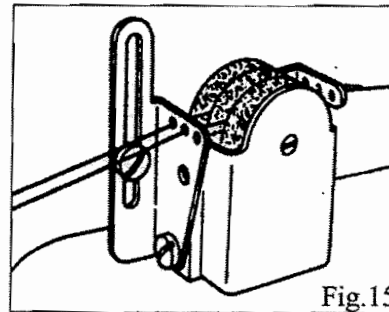
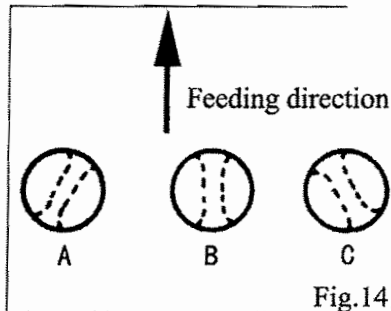

## 13. ADJUSTING THE HEIGHT OF PRESSER FOOT (Fig.16)

For the requirements of either replacing the presser foot or changing the height and angle of presser foot, the following shall be observed.

Take off the rubber plug in the hole from the face plate, as shown in Fig.16.

Loosen the presser bar guide bracket set screw.

After adjusting, tighten the screw.

## 14. ADJUSTING THE HEIGHT OF FEED DOG (Figs.17,18)

Loosen the set screw as shown in Fig.18, the angle of the feed dog can be adjusted to the specified one of standard, A type and B type. The Max. height of the feed dog 0.8mm is adjustable by the adjusting screw as shown in Fig.17.

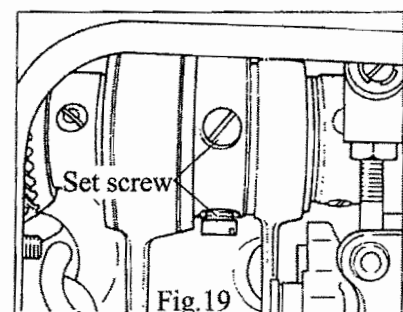
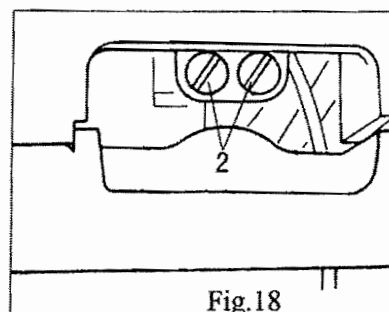
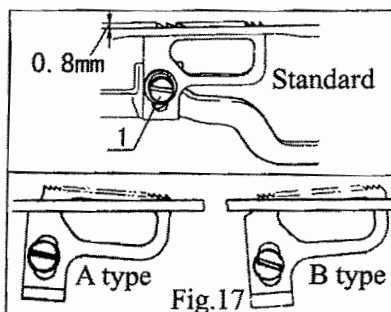

## 15. TIMING OF FEED DOG AND NEEDLE (Fig.19)

When the point of needle fall down to the location of 3mm from the upper surface of the needle plate, the feed dog is right at the position below the upper surface of needle plate, the motion of feed dog being well regulated relation to the motion of needle.



## 16. ADJUSTING THE HEIGHT OF NEEDLE BAR(Fig.20)

Set the needle bar height as shown in Fig 20 when using a needle 149 x 5.

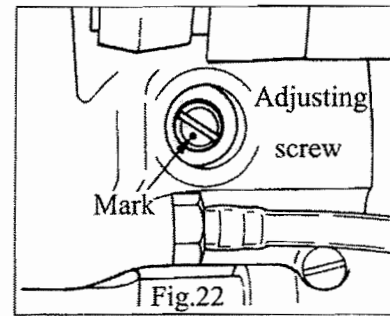
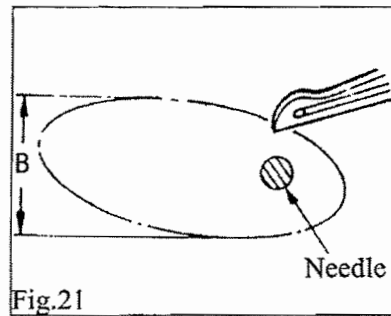
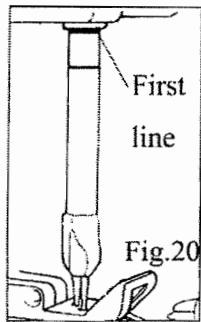

## 17. ADJUSTING THE NEEDLE AND THE LOOPER(Figs.21,22)

Adjustment of forward & backward motion of the looper: The dimension B is the looper in an elliptical motion can be measured (refer to Fig.21). The Max. dimension of part B is usually 3.7mm, suitable for sewing operation of needle of all kinds of sizes.

The adjusting procedure is as follows:

- (1) Take off the rubber plug on the crank case of the looper.
- (2) Turn the balance wheel by hand.
- (3) First loosen set screw and position screw, and then adjust marked screw.
- (4) Turn clockwise the adjustable screw on which punch mark is printed, and the dimension of part B will be increased in value. Otherwise also.
- (5) Tighten set screw and position screw.

## 18. TIMING OF LOOPER AND NEEDLE(Fig.23)

The looper shall be moved backward to the lowest position while the needle is at the bottom dead point; loosen the screw on the gear and make timing adjustment of the looper in relation to the needle (refer to Fig.23)

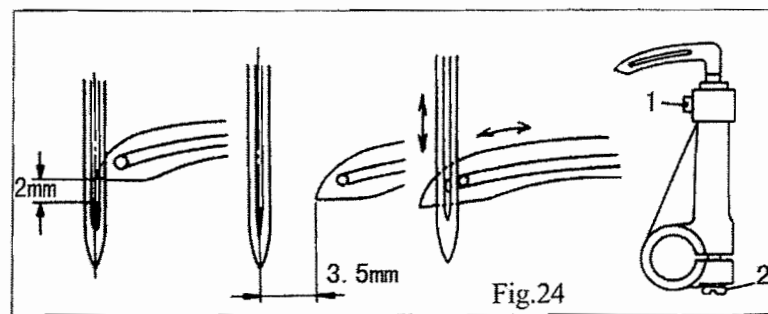
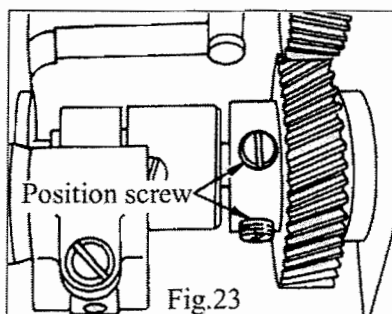

## 19. LOOPER TAKE-UP THREAD(Fig.24)

(1) The standard value of the vertical distance of the point of the looper away from the upper end of the needle eye is 2mm, then the graduation mark on the lower part of the needle bar shall be in line with the lower

end of the needle bar bushing.

(2) The value of the stroke moved backward by the looper is about 3.5mm.

(3) The relation between the eye of the needle and the eye of the looper is indicated in Fig.24.

**(Note: That the left looper and the right one can be separately adjusted.)**

## 20. CLEARANCE BETWEEN LOOPER AND NEEDLE

After adjusting the looper guard, the clearance of a given value between the needle and looper shall be kept unchanged; the needle shall not touch at the point of the looper when it is pressed down softly. If the clearance is narrower than usual, the side of the needle and the point of the looper are apt to incur breakage due to the impact of the needle side against the looper point.

## 21. TIMING OF LOOPER GUARD (Fig.25)

The timing of the looper guard depends on the condition of the surface on the rock shaft of the looper when first screw has been screwed into this rock shaft.

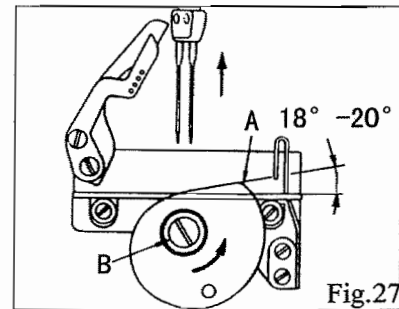
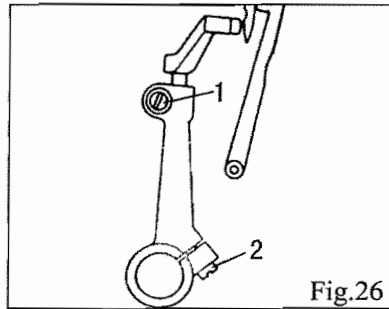
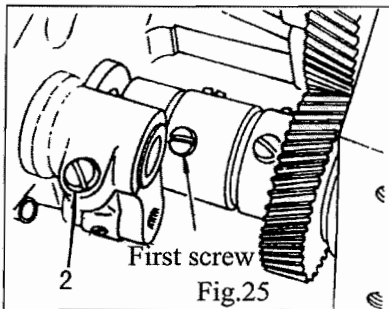

## 22. POSITION OF LOOPER GUARD (Fig.26)

Oscillating the looper guard to make the needle tip contact with needle gauge slightly.

It is recommended that the height adjustment shall not fall within the area of the looper guard; loosen screws (1) (2) then adjust. The relation between looper guard and the swing looper guard is as represented in Fig.26. The clearance is about 0.1 to 0.2mm between the needle and looper guard.

**(Note: That the forced clamp of the needle shall be prohibited when the machine is in motion.)**

## 23. BOBBIN THREAD TAKE-UP CAM (Fig.27)

Its position can be seen as shown in Fig.27 when the needle bar is at the top dead point, the surface of the cam and the steel wire at the angle of  $18^{\circ}$  to  $20^{\circ}$ ; first loosen screw B, then make adjustment, finally tighten the screw firmly. Pay close attention to the following: Bobbin thread take off from the projecting part (A) of the cam, the needle tip shall entirely come into the bobbin thread loop.

## 24. THE POSITION OF THE THREAD-AMOUNT ADJUSTING PLATE OF THE THREAD TAKE-UP LEVER(Fig.28)

The thread-amount adjusting plate will retain the bobbin thread when the needle bar at the bottom dead point;in such a way the loop of the needle thread is to become bigger when the needle thread is hooked.In addition,there is a function of the tight pulling of the needle thread loop.The thread-amount adjusting plate usually reduces to the lowest point when a thread thinner than normal is used.

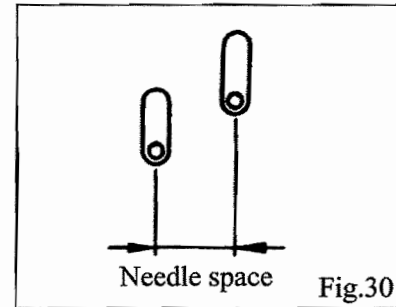
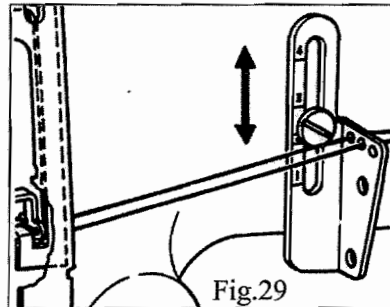
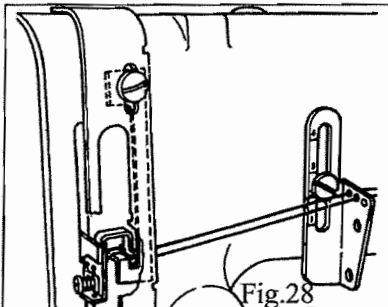

## 25. THREAD GUIDE HOOK(Fig.29)

The improper-position of the frame thread eyelet may be the cause of occurrence of skipping stitch.

The following location are generally regarded as criteria.

Cotton	thread # 80~ # 50	Graduation on thread guide	2-3
Cotton	thread # 30~ # 20	Graduation on thread guide	3-4
Thread of chemical fibre	# 80~ # 50	Graduation on thread guide	1-2
Thread of chemical fibre	# 30~ # 20	Graduation on thread guide	2-3

## 26. CHANGING THE NEEDLE SPACE(Fig.30)

The replacement of the following components is usually needed when changing the needle space:

- 1.Needle plate    2.Walking foot                    3.Needle plate
- 4.Feed dog    5.Swing looper guard            6.Curler    7.Presser foot

The left and right loopers can be used when the needle plate within the sizes of 1/8"-1/2".

In addition to the aforesaid,the replacement of slide plate and cam cover shall be made when the width of needle plate is on the increase.

## 27. MAINTAIN THE MACHINE

The following shall be adhered to in order to keep the machine in good working condition:

Daily checking:

- (1) The oil shall spray onto the oil window when the machine is running.
- (2) Repairman shall be sent for when abnormal sound is heard during the operation of the machine.

Weekly checking:

(1) Remove needle plate, slide plate, and cam cover; to clean dust of the the slotted feed dog with a brush.

(2) To turn over the head to rid both the oil filter on the oil pump and the interior of the oil reservoir of oil stain and dust.

(3) Loosen drain screw and take it off; drain all the dirty oil from the oil reservoir and reoil it.

(4) Oil lever must be above the lowest oil-lever-indicating line marked "Low".

(5) The black powder, adhering to the magnet in the oil reservoir shall be wiped with sponge cloth.

## 28. MEASURES OF COMMON TROUBLES

No.	Troubles	Cause	Measures to be taken
1	Thread breakage	1. Poor thread quality 2. Thread being too thick  3. Fusing thread due to high temperature of needle 4. Thread's tension too higher 5. Breakage of needle, looper, and looper guard at the location of thread guide 6. Failure to adjust thread amount	1. Using quality thread 2. Replacement to be made by an appropriate thread 3. Silicone oil to be used and speed to be reduced 4. The tension nut to be loosened 5. First grinding with oil stone and then polishing 6. Adjusting the thread amount adjusting plate
2	Skipping stitch	1. Skipping stitch of needle thread (leaking of two stitches due to the loopers failure to hook the needle thread)  2. Skipping stitch of bobbin thread (leaking of one stitch, needle's failure to enter the looper eyelet)	1. Adjusting thread-hooking amount of looper 2. Adjusting clearance between looper and needle 3. The timing of needle in reference to looper 4. Adjusting the thread-amount adjusting plate on thread amount changing conditions 5. Adjusting the frame thread eyelet 6. Checking whether the mounting position of the needle is proper or not 7. Checking if the location of looper guard is in an appropriate way and the timing of it is well 8. Checking if the needle thread threading is in a proper way  1. Reference to the above cases 1 and 2, as to skipping stitch of the needle thread 2. Checking if the timing of the bobbin thread cam has been well regulated 3. Increasing tension of bobbin thread a bit

			higher 4. Checking if the threading of bobbin thread is in a correct way
		3. Skipping stitch when thread of chemical fiber being in use	1. Using silicone oil 2. Reducing speed 3. Using needle for thread of chemical fibre
		4. Skipping stitch when thread of polyester fiber being in use	1. Reducing speed 2. Silicone oil to be used
3	Twisted stitches	1. Needle thread tension being too low 2. Bobbin thread tension being too low 3. Sewing thread being too thick 4. Improper position of the frame thread eyelet 5. Improper position of thread take-up tension plate 6. Needle plate	1. Tightening tension nut of needle thread 2. Tightening tension nut of bobbin thread 3. Needle of large size to be used 4. Readjusting it to a proper position  5. Readjusting its position in an appropriate way 6. The eyelet of needle plate to be used being bigger than normal one
4	Breakage of needle	1. Needle being bent  2. The operation of feed dog being not well regulated in reference to the motion of needle 3. Setting-up of the presser foot  4. The problem of the timing of looper guard remaining unsolved 5. Needle thread tension being too high 6. Needle being too thick	1. Needle to be replaced by another of proper size 2. Readjusting the timing to feed dog on respect to the needle  3. To make both the centre of the hole of the presser foot and the centre of the eyelet of the needle plate be in line with that of the eye of the needle 4. The position & the timing of the looper guard to be taken into account 5. Relaxing needle thread 6. Appropriate needle to be used
5	Puckering	1. Thread tension being too high  2. The problem of the timing of the bobbin thread cam for thread guiding failing 3. The problem of surface finish arising from bobbin thread going through the parts on the thread guide 4. The force on the presser foot being too high	1. Decreasing thread tension, esp. tension of bobbin thread 2. Readjusting the timing of the cam  3. Surface finishing all the parts on the thread guide 4. Loosen the pressure-regulating screw

# A. ARM BED AND IT'S ACCESSORIES

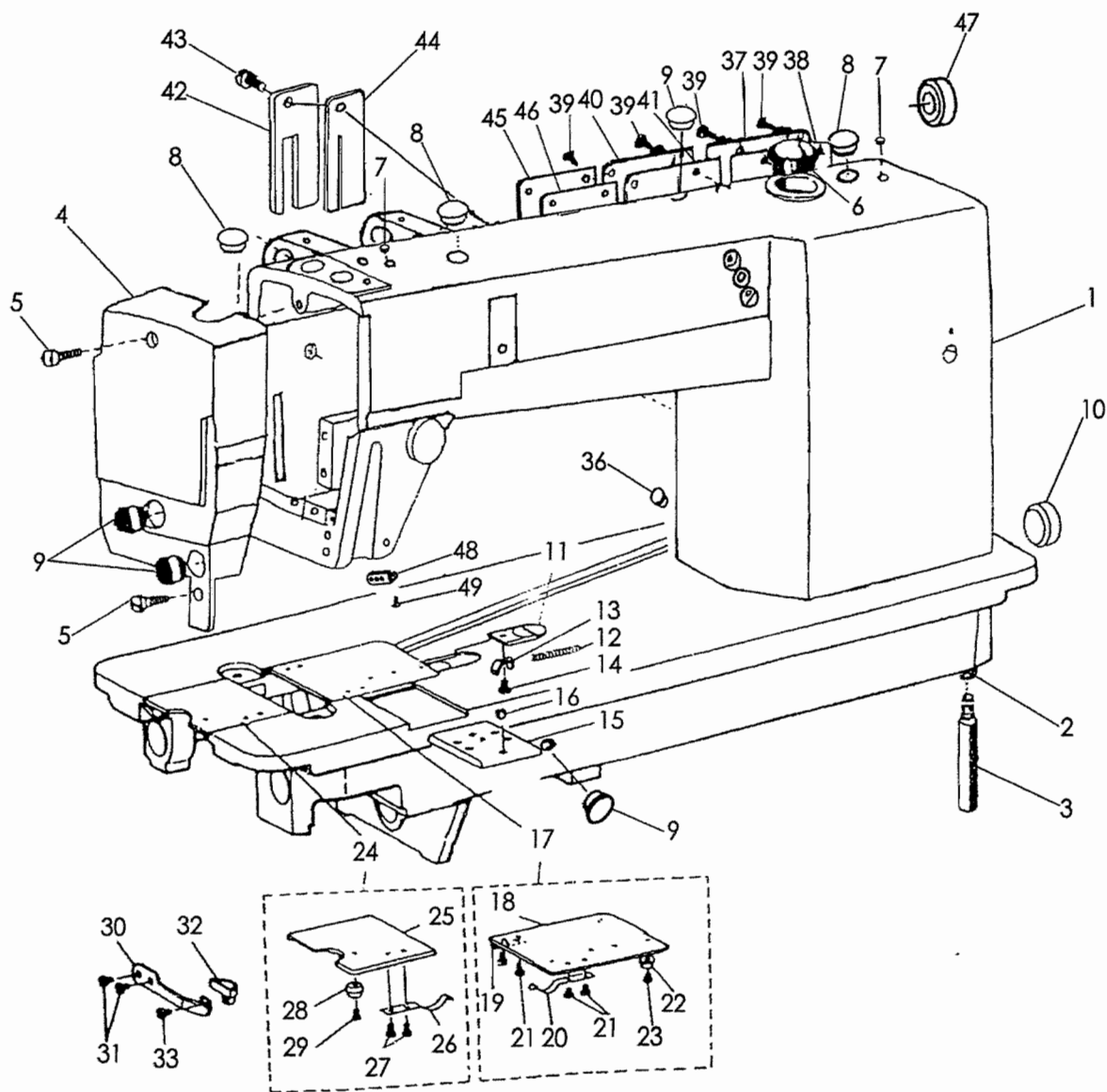

## A. ARM BED AND IT'S ACCESSORIES

Fig. No.	Part No.	Description	Pcs.	Notes
A01		Arm bed	1	
A02	H005008060	Washer	1	
A03	7WF4-013	Machine supporting bolt	1	
A04	H2005B0065	Face plate	1	
A05	7WF4-004	Screw	2	
A06	14WF4-004	Oil window	1	
A07	HA300B2110	Rubber plug	2	φ 5.7
A08	HA307B0673	Rubber plug	3	φ 19
A09	HA306B0674	Rubber plug	4	φ 11.8
A10	HA300B2100	Rubber plug	1	φ 27
A11	GR1813	Cam cover plate	1	
A12	GW287	Spring	1	
A13	GR1814-1	Spring block	1	
A14	GS069-1	Screw	1	
A15	GM241	Bracket	1	
A16	GS012(T)	Position screw	1	
A17	GM242/9	Cam cover complete	1	
A18	GM243	Cam cover	1	1/4"
A19	GW289	Supporting plate	1	
A20	GW290	Spring	1	
A21	GS045	Screw	4	
A22	GR1815	Guiding wheel	1	
A23	GS0129	Screw	1	
A24	GM244/6	Slide plate complete	1	
A25	GM245	Slide plate	1	1/4"
A26	GW291	Spring	1	
A27	GS045	Screw	2	
A28	GR1816	Guiding wheel	1	
A29	GS0129	Screw	1	
A30	GW292	Lock spring	1	
A31	GS010	Screw	2	
A32	GR1817	Handle	1	
A33	GS44	Screw	1	
A36	HA300B2090	Rubber plug	1	φ 8.8
A37	H6409B8001	Back cover plate	1	
A38	H6410B8001	Gasket	1	
A39	HA300B2160	Screw	13	
A40	H6028B8001	Side cover plate	1	
A41	H6029B8001	Gasket	1	
A42	7WF4-011	Oil block plate	1	
A43	HA100E2040	Screw	1	
A44	H2100B2130	Felt	1	
A45	GK186	Bracket	1	
A46	GR1812	Gasket	1	
A47	H6030B8001	Rubber plug	1	φ 22
A48	GR1880/2	Thread guide	1	
A49	GS100	Screw	1	SM9/64×40

# B. ARM SHAFT AND NEEDLE BAR MECHANISM

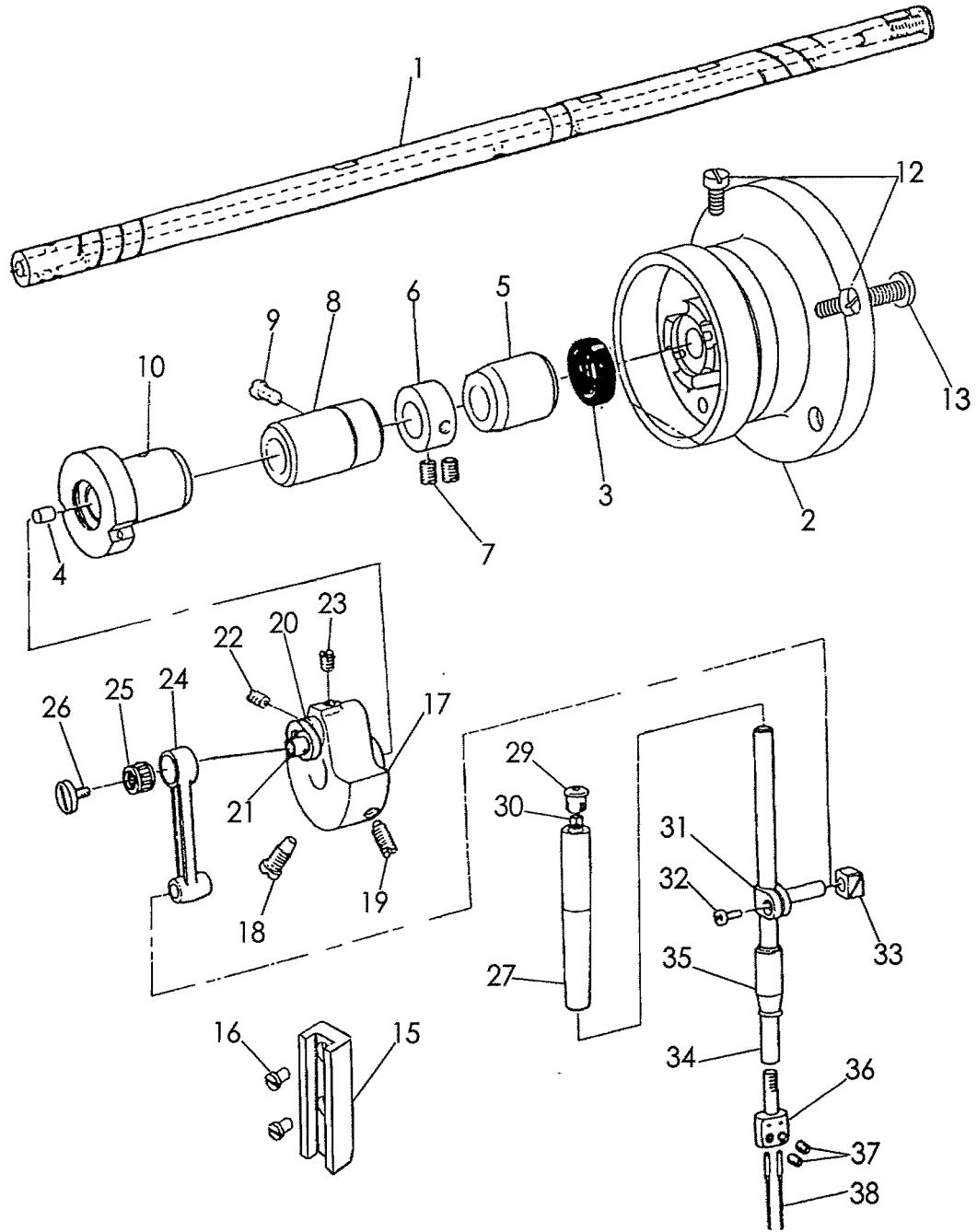



## B. ARM SHAFT AND NEEDLE BAR MECHANISM

Fig. No.	Part No.	Description	Pcs.	Notes
B01	H2604C0651	Arm shaft	1	
B02	7WF1-001	Machine pulley	1	
B03	HA306D0066	Oil seal	1	
B04	HA104D0652	Rubber plug	2	
B05	HA300D2020	Arm shaft bushing(back)	1	
B06	GR1824	Collar for arm shaft	1	
B07	GS033	Screw	2	
B08	GC15-1	Arm shaft bushing(center)	1	
B09	GS05	Screw	1	
B10	33T1-007D1	Arm shaft bushing(front)	1	
B12	HA110D0672	Screw	2	
B13	HA100D2080	Screw	1	
B15	33T1-012	Guide for slide block	1	
B16	HA100C2190	Screw	2	
B17	33T1-006C1	Needle bar crank	1	
B18	61-04-01/B2	Position screw	1	
B19	33T1-006C2	Screw	1	
B20	GR1838	Stop ring	1	
B21	GH379	Thread take-up crank	1	
B22	HA108C0663	Position screw	1	
B23	33T1-006C3	Screw	1	
B24	GH334	Needle bar link	1	
B25	G0270	Needle bearing	1	
B26	GS09	Screw(left hand)	1	
B27	HA100C2080	Needle bar bushing(upper)	1	
B29	HA100C2110	Rubber plug	1	φ 8.8
B30	HA100C2100	Felt	1	
B31	HA104C0658	Needle bar joint	1	
B32	GS011	Screw	1	
B33	33T1-013	Slide block	1	
B34	GZ304	Needle bar	1	
B35	34T1-001	Needle bar bushing(lower)	1	
B36	GR1826	Needle clamp	1	1/4"
B37	GS0130	Screw	2	
B38	GV18	Needle	2	TV×5 18-23#

# C. PRESSER FOOT MECHANISM

---

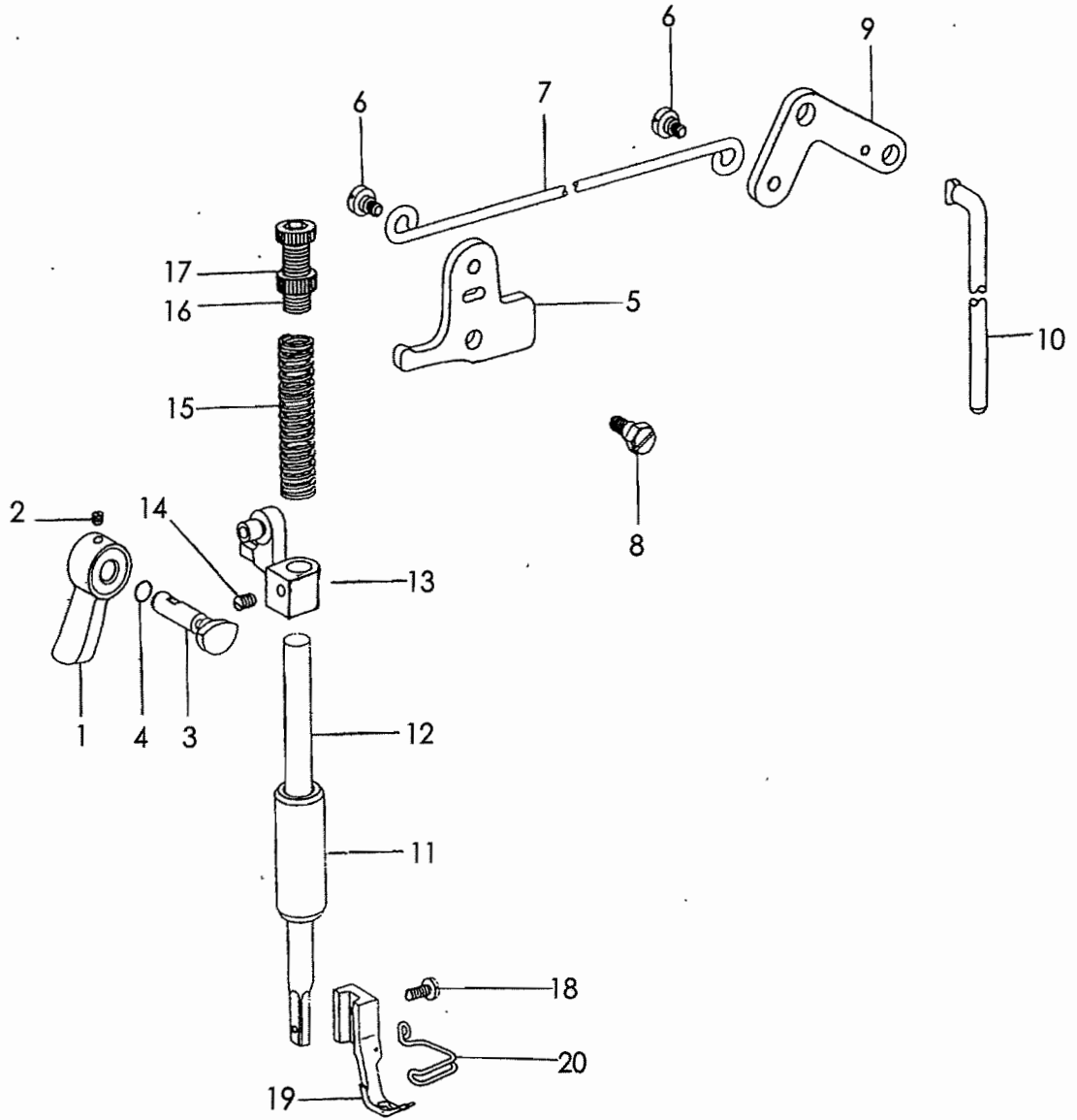

### C. PRESSER FOOT MECHANISM

Fig. No.	Part No.	Description	pcs.	Notes
C01	H2104H0651	Presser bar lifter	1	
C02	HA100B2110	Screw	1	
C03	H2104H0661	Presser bar lifter cam	1	
C04	HA300H2080	O-ring	1	
C05	HA107H1013	Knee lifter lever(left)	1	
C06	HA107H0662	Hinged screw	2	
C07	HA107H0663	Knee lifter rod	1	
C08	H3211E0692	Screw	2	
C09	HA110H0671	Knee lifter lever(right)	1	
C10	GR3370	Knee lifter connecting rod	1	
C11	HA300H2090	Presser bar bushing	1	
C12	H2000I2010	Presser bar	1	
C13	7WF3-001	Presser bar bracket	1	
C14	61-04-01/B308	Screw	1	
C15	20T4-002	Presser spring	1	
C16	34T3-301	Presser regulating thumb screw	1	
C17	HA117H0692	Lock nut	1	
C18	HA100H2150	Screw	1	
C19	GM322	Presser foot	1	1/4"
C20	GR1499	Presser foot guard	1	

# D. FEEDING AND FEED LIFTING MECHANISM

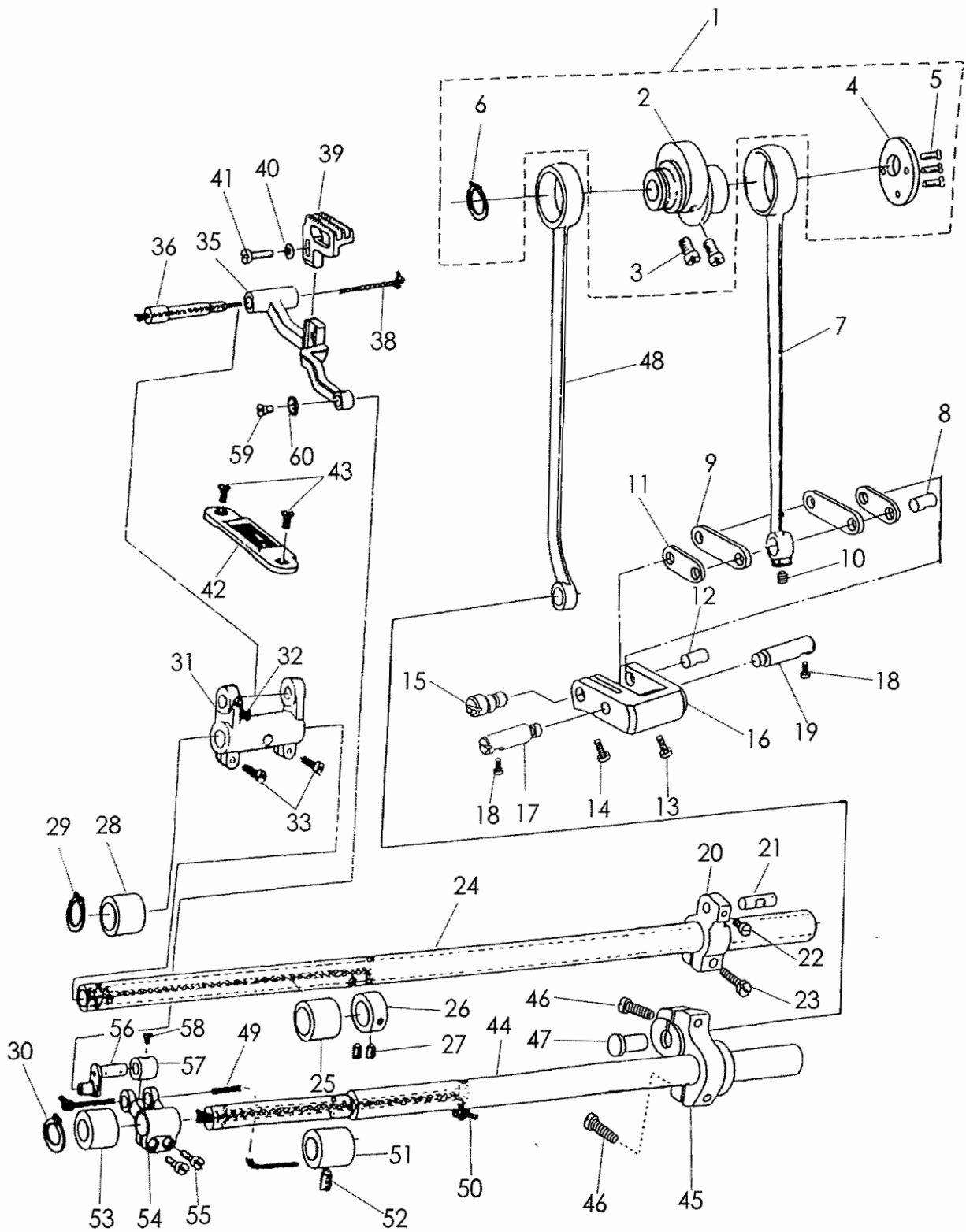

## D. FEEDING AND FEED LIFTING MECHANISM

Fig. No.	Part No.	Description	Pcs.	Notes
D01	GT160/10	Feed cam complete	1	
D02	H6510D8001	Feed cam	1	
D03	GS034	Screw	2	
D04	H6511D8001	Feed cam cover plate	1	
D05	GS035	Screw	3	
D06	GR1535	C-type retaining ring	1	
D07	HA7311C506	Feed link	1	
D08	HA706C11B1	Link stud	1	
D09	36T5-008E4H02	Link(long)	2	
D10	36T5-008E5	Screw	1	
D11	36T5-008E4H01	Link(short)	2	
D12	HA7311CE06	Link stud	1	
D13	36T5-008E7	Screw	1	
D14	36T5-008E8	Screw	1	
D15	36T5-008E9	Eccentric shaft	1	
D16	36T5-008E10	Feed regulator crank	1	
D17	HA700C2050	Position pin(left)	1	
D18	HA111G0683	Screw	2	
D19	5WF1-001	Position pin(right)	1	
D20	HA8211C205	Feed rock shaft crank ( right )	1	
D21	HA7311CB06	Hinge pin	1	
D22	HA7311C806	Screw	1	
D23	HA7311C606	Screw	1	
D24	7WF-004	Feed shaft	1	
D25	7WF2-003	Feed shaft bushing(center)	1	
D26	HA108G0661	C-type retaining ring	1	
D27	HA105D0662	Screw	2	
D28	7WF2-002	Feed shaft bushing(front)	1	
D29	GR1542	C-type retaining ring	1	
D30	H007009150	C-type retaining ring	1	
D31	HA104G0011	Feed lifting rock shaft fork	1	
D32	HA100C2190	Screw	1	
D33	HA304G0656	Screw	2	
D35	GR1839	Feed bar assay	1	
D36	H241010110	Eccentric shaft	1	
D38	GR1837	Oil braid	1	
D39	GM247	Feed dog	1	1/4"
D40	GR1528	Washer	1	
D41	GS019	Screw	1	
D42	GM248	Needle plate	1	1/4"
D43	GS044	Screw	2	
D44	GZ306	Feed dog lifting shaft	1	
D45	4WF2-003	Feed dog lifting crank	1	

## D. FEEDING AND FEED LIFTING MECHANISM

Fig. No.	Part No.	Description	Pcs.	Notes
D46	J0. 0. 71	Screw	2	
D47	HA100G2070	Hinge pin	1	
D48	HA112D0681	Feed lifting rod	1	
D49	GR1837	Oil braid for feed bar rod	1	
D50	GR1837	Oil braid	2	
D51	G0300	Feed dog lifting shaft bushing(center)	1	
D52	GS04	Screw	1	
D53	G0306	Feed dog lifting shaft bushing(front)	1	
D54	GH382	Feed dog lifting shaft crank(front)	1	
D55	GS0132	Screw	2	
D56	GH383	Feed bar rod	1	
D57	GR1841	Stop ring	1	
D58	GS032	Screw	1	
D59	GS0133	Screw	1	
D60	GR1842	Washer	1	

# E. STITCH REGULATOR MECHANISM

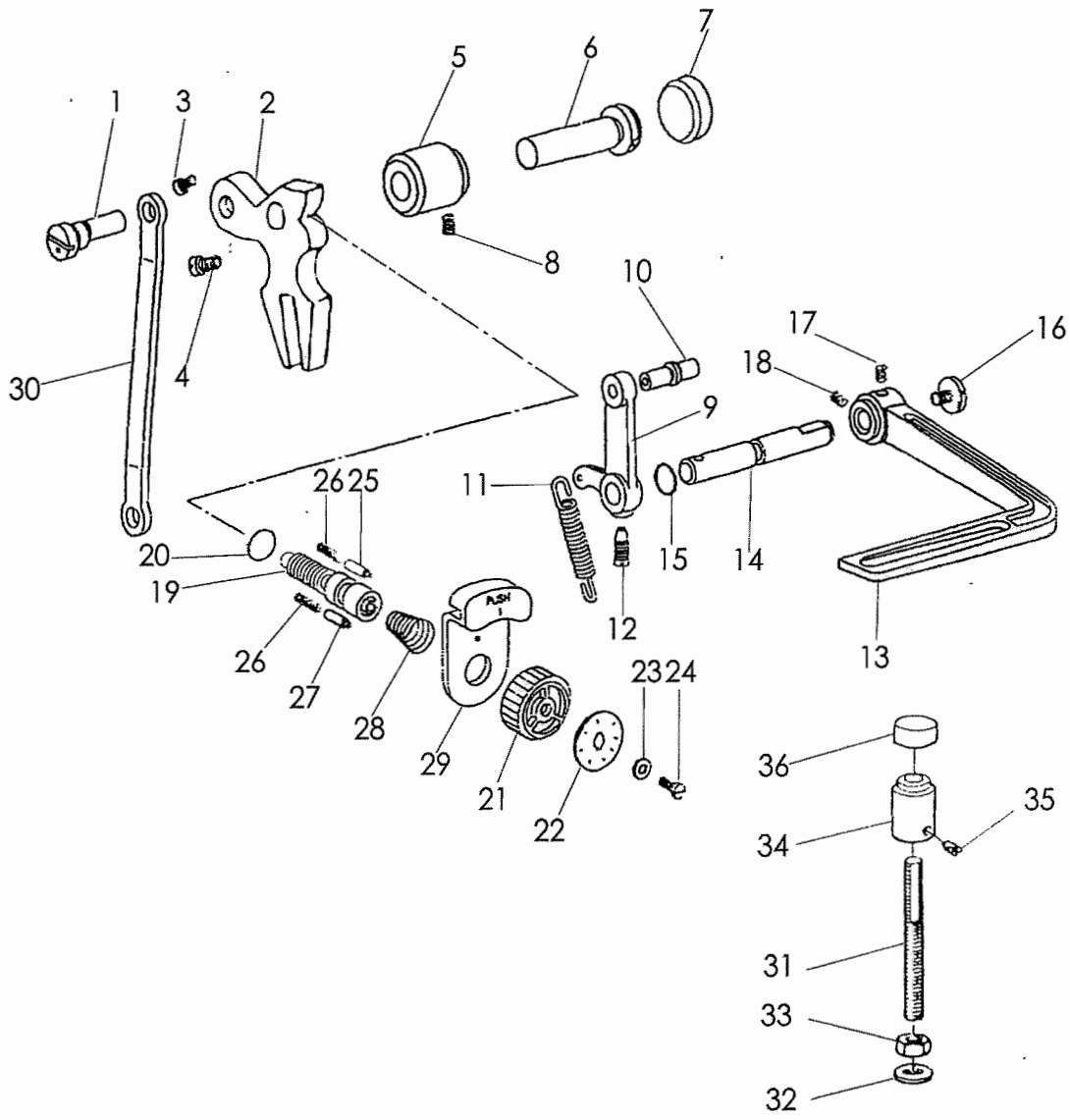

## E. STITCH REGULATOR MECHANISM

Fig. No.	Part No.	Description	Pcs.	Notes
E01	H1204E0652	Hinge pin	1	
E02	H1404E0651	Feed regulator	1	
E03	HA111G0683	Screw(long)	1	
E04	HA113F0684	Screw(short)	1	
E05	4WF2-008	Feed regulator bushing	1	
E06	HA100F2040	Hinge pin	1	
E07	36T5-003	Rubber plug	1	φ 20
E08	JO. 0. 40	Set screw	1	
E09	7WF2-009	Reverse feed crank	1	
E10	7WF2-008A	Roller shaft assy	1	
E11	HA115F0692	Spring for feed crank	1	
E12	HA100F2130	Screw	1	
E13	7WF2-007A	Reverse feed lever	1	
E14	HA113F3021	Reverse feed lever shaft	1	
E15	HA113F3022	O-ring	1	
E16	HA113F0683	Screw	1	
E17	17T5-016	Screw	1	
E18	17T5-017	Screw	1	
E19	36T5-007D1	Feed regulator screw bar	1	
E20	HA109F0674	O-ring	1	
E21	36T5-007D2	Stitch pan	1	
E22	HB5253F081	Dail	1	
E23	36T5-007D4	Bushing	1	
E24	36T5-007D5	Screw	1	
E25	36T5-012	Stop pin	1	
E26	HA100F2090	Spring for stop pin	1	
E27	7WF2-006	Pin	1	
E28	36T5-011	Spring	1	
E29	7WF2-005	Keystoke	1	
E30	HA7311C406	Connecting rod stud	1	
E31	GS0134	Screw bar	1	
E32	GR1599	Washer	1	
E33	GL21	Nut	1	
E34	GR1844	Reverse feed block	1	
E35	GS0135	Screw	1	
E36	GR1845	Rubber mat	1	



# F. UPPER FEED LIFTING ROCK SHAFT MECHANISM

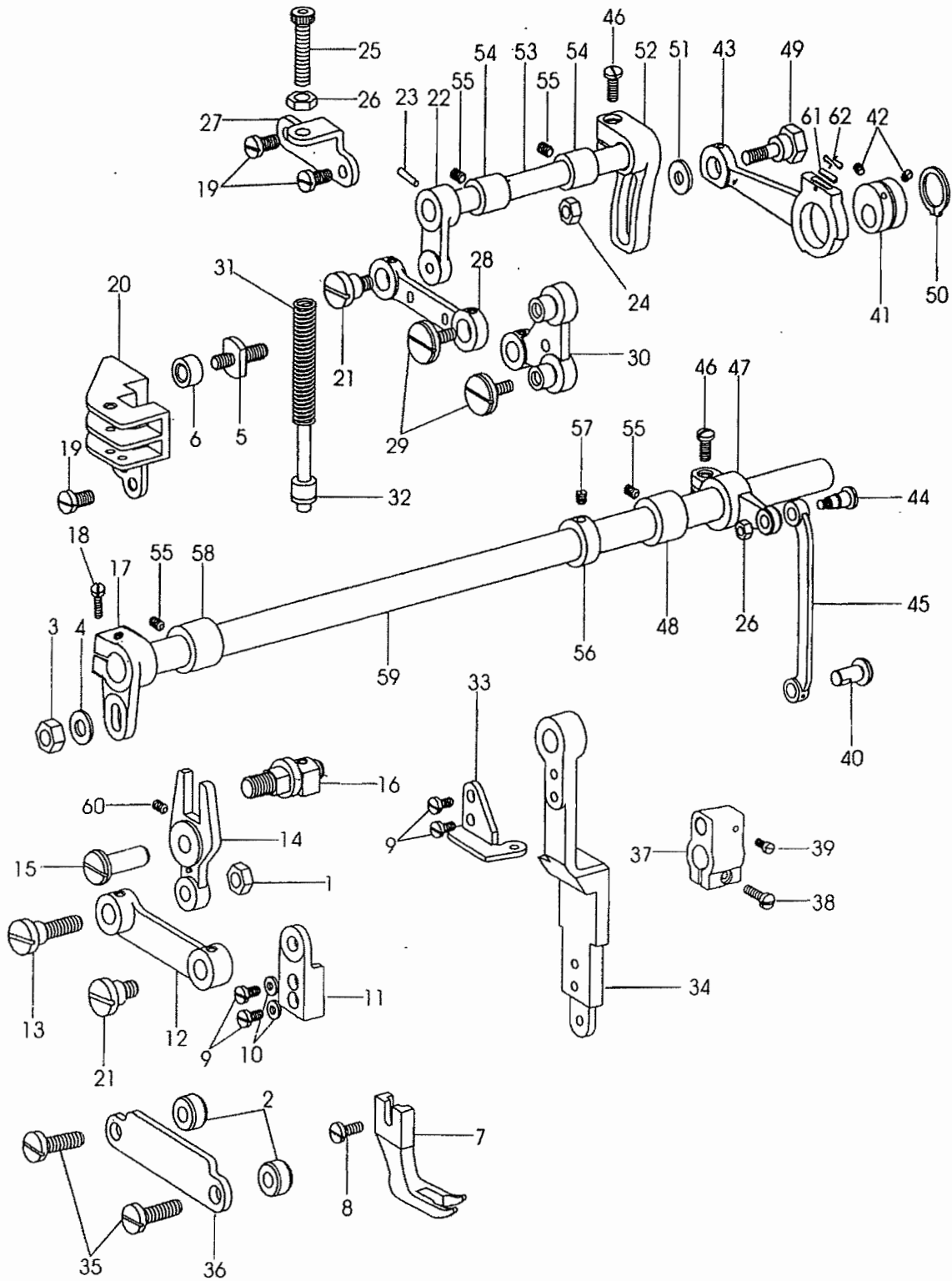

## F. UPPER FEED LIFTING ROCK SHAFT MECHANISM

Fig. No.	Part No.	Description	Pcs.	Notes
F01	7WF5-001	Lock nut	1	
F02	7WF5-002	Space for presser rod plate	2	
F03	7WF5-003	Presser crank connecting nut	1	
F04	35T5-504	Washer	1	
F05	7WF5-004	Feed crank guide pin	1	
F06	7WF5-005	Presser lifting roller shaft	1	
F07	GM328	Walking foot	1	1/4"
F08	7WF5-007	Screw	1	
F09	7WF5-008	Screw	4	
F10	HA100I2050	Spring washer	2	
F11	7WF5-009	Presser rod guide	1	
F12	7WF5-010	Presser swing crank	1	
F13	7WF5-011	Screw	1	
F14	7WF5-012	Lifting presser swing crank	1	
F15	7WF5-013	Lifting presser swing crank guide pin	1	
F16	7WF5-014A	Lifting presser swing crank shaft	1	
F17	7WF5-016	Presser swing crank (front)	1	
F18	H6017F8001	Set screw	1	
F19	7WF5-017	Screw	4	
F20	7WF5-018	Lifting presser plate	1	
F21	7WF5-019	Screw	2	
F22	7WF5-020	Presser lifting crank (front)	1	
F23	H602040200	Pin	1	
F24	H0030020608	Nut	1	
F25	7WF5-021	Lifting presser adjusting screw	1	
F26	7WF5-022	Lifting presser adjusting nut	2	
F27	7WF5-023	Lifting presser bracket for spring	1	
F28	7WF5-024	Presser feed crank link	1	
F29	7WF5-025	Screw	2	
F30	7WF5-026	Presser feed crank	1	
F31	7WF5-027	Lifting presser spring	1	
F32	7WF5-028	Presser spring guide	1	
F33	7WF5-029	Lifting presser guide plate	1	
F34	7WF5-030	Presser rod	1	
F35	HA111G0683	Screw	2	
F36	7WF5-031	Lifting presser rod plate	1	
F37	H6504G8001	Feed shaft crank (center)	1	
F38	HA104G0012	Screw	1	
F39	HA104F0654	Screw	1	
F40	H6505G8001	Hinge pin	1	
F41	7WF5-032	Eccentric wheel	1	
F42	7WF5-033	Screw	1	
F43	7WF5-034A	Eccentric wheel rod	2	

## F. UPPER FEED LIFTING ROCK SHAFT MECHANISM

Fig. No.	Part No.	Description	Pcs.	Notes
F44	7WF5-037	Screw	1	
F45	7WF5-038	Presser swing crank(back) rod	1	
F46	7WF5-039	Screw	2	
F47	7WF5-040	Presser swing crank(back)	1	
F48	7WF5-041	Presser swing crank(back) bushing	1	
F49	7WF5-042	Screw	1	
F50	H007009250	C-type ring	1	
F51	7WF5-049	Washer	1	
F52	7WF5-043	Eccentric rod adjusting crank	1	
F53	7WF5-044	Presser lifting shaft	1	
F54	7WF5-045	Presser lifting shaft bushing	2	
F55	J0. 0. 35	Screw	4	
F56	HA105D0661	Presser swing shaft collar	1	
F57	HA105D0662	Screw	2	
F58	7WF5-046	Presser swing shaft bushing(front)	1	
F59	7WF5-047	Presser swing shaft	1	
F60	7WF5-048	Screw	1	
F61	H20111C206	Felt	1	
F62	H20111C106	S-type spring	1	

# G. LOOPER MECHANISM

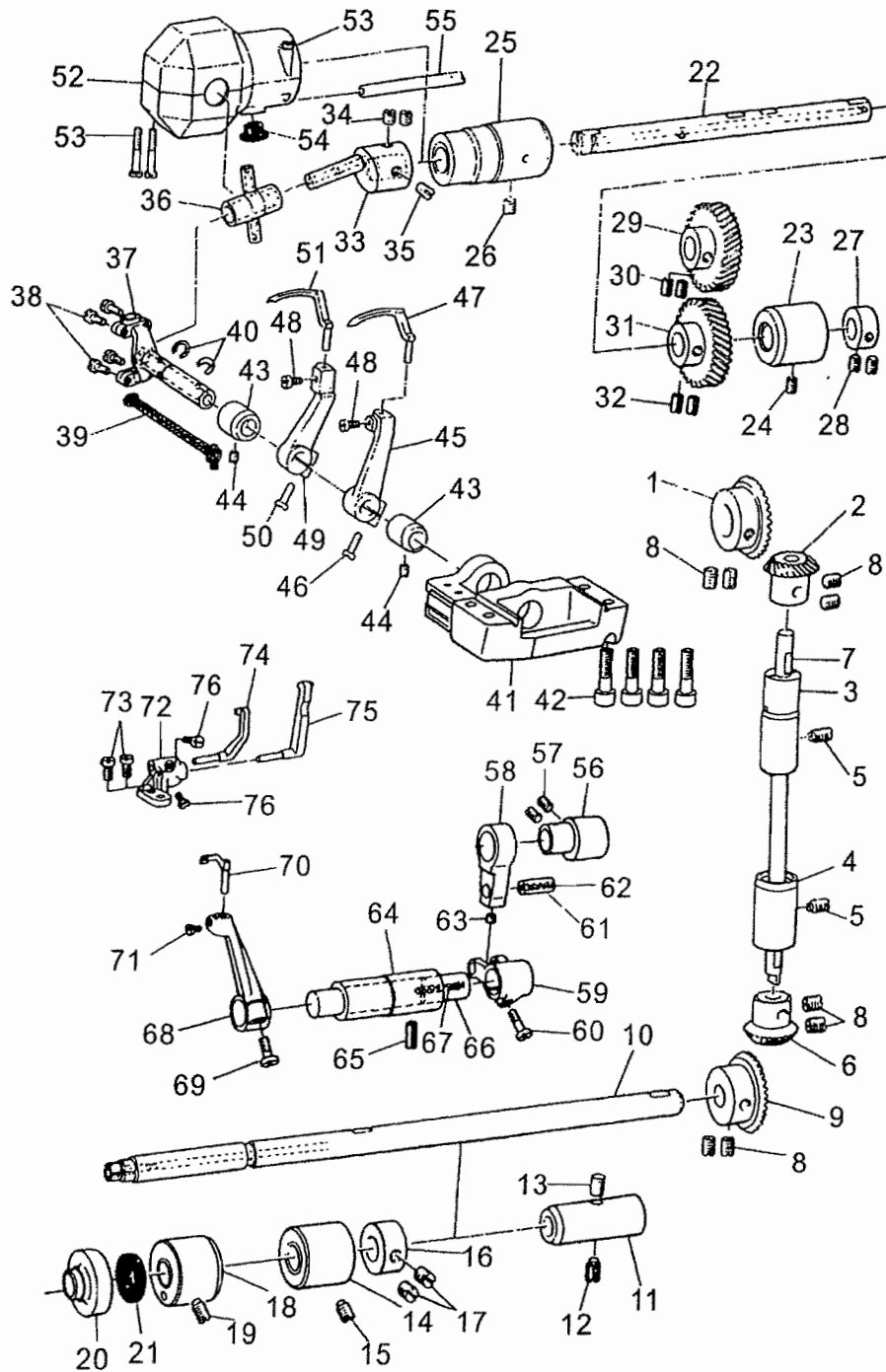

## G. LOOPER MECHANISM

Fig. No.	Part No.	Description	Pcs.	Notes
G01	GC168	Bevel gear for arm shaft	1	
G02	GC167/4	Bevel gear for vertical shaft(upper)	1	
G03	G0283	Vertical shaft bushing(upper)	1	
G04	G0280/2	Vertical shaft bushing(lower)	1	
G05	GS04	Screw	2	
G06	GC167	Bevel gear for vertical shaft(lower)	1	
G07	GZ307	Vertical shaft	1	
G08	GS033	Screw	8	
G09	GC169	Bevel gear for hook shaft	1	
G10	GZ308	Hook shaft	1	
G11	G0307	Hook shaft bushing(back)	1	
G12	GS04	Screw	1	
G13	GR1847	Felt	1	
G14	G0308/2	Hook shaft bushing(back)	1	
G15	GS04	Screw	1	
G16	GR1848	Hook shaft collar	1	
G17	GS033	Screw	2	
G18	G0311/2	Hook shaft bushing(front)	1	
G19	GS04	Screw	1	
G20	GR1849	Oil seal bushing	1	
G21	GR1850	Oil seal	1	
G22	GZ309	Looper shaft	1	
G23	G0308/2	Looper shaft bushing(back)	1	
G24	GS04	Screw	1	
G25	G0314/2	Looper shaft bushing(front)	1	
G26	GS48	Screw	1	
G27	GR1848	Looper shaft collar	1	
G28	GS033	Screw	2	
G29	GC170	Initiative looper gear	1	
G30	GS033	Screw	2	
G31	GC171	Passivity looper gear	1	
G32	GS033	Screw	2	
G33	GH384	Looper crank	1	
G34	GS033	Screw	2	
G35	GS0136	Adjusting screw	1	
G36	GR1851/5	Looper cross joint	1	
G37	GZ310/3	Looper swing shaft	1	
G38	GS0100	Screw	1	
G39	GR1533	Oil braid	1	
G40	GR1854	Looper swing shaft collar	2	
G41	GR1855	Looper bracket	1	
G42	GS0137	Screw	4	
G43	G0318	Looper swing shaft bushing	2	

## G. LOOPER MECHANISM

Fig. No.	Part No.	Description	Pcs.	Notes
G44	GS032	Screw	2	
G45	GH385	Looper crank (left)	1	
G46	GS040	Screw	1	
G47	GN169	Looper (left)	1	
G48	GS0138	Screw	2	
G49	GH386	Looper crank (right)	1	
G50	GS0561	Screw	1	
G51	GN170	Looper (right)	1	
G52	GK187/7	Looper crank cover	1	
G53	GS0139	Screw	3	
G54	GR1462	Plug	1	
G55	GR1856	Oil drain pipe	1	
G56	GT162	Looper guard cam	1	
G57	GS48	Screw	2	
G58	GH387	Looper guard rod	1	
G59	GH388	Looper guard furcation crank	1	
G60	GS019	Screw	1	
G61	GX380	Looper guard crank pin	1	
G62	GR1837	Oil braid	1	
G63	GS032	Screw	1	
G64	G0319	Looper guard shaft bushing	1	
G65	GS48	Screw	1	
G66	GZ312	Looper guard shaft	1	
G67	GR1837	Oil braid	1	
G68	GH389	Looper guard crank	1	
G69	GS0561	Screw	1	
G70	GR1857	Looper guard swing rod	1	1/4"
G71	GS0100	Screw	1	
G72	GR1858	Looper guard rod bracket	1	
G73	GS0106	Screw	2	
G74	GR1859	Looper guard rod (left)	1	
G75	GR1860	Looper guard rod (right)	1	
G76	GS0138	Screw	2	

# H. TAKE-UP THREAD TENSION AND RELEASE MECHANISM (1)

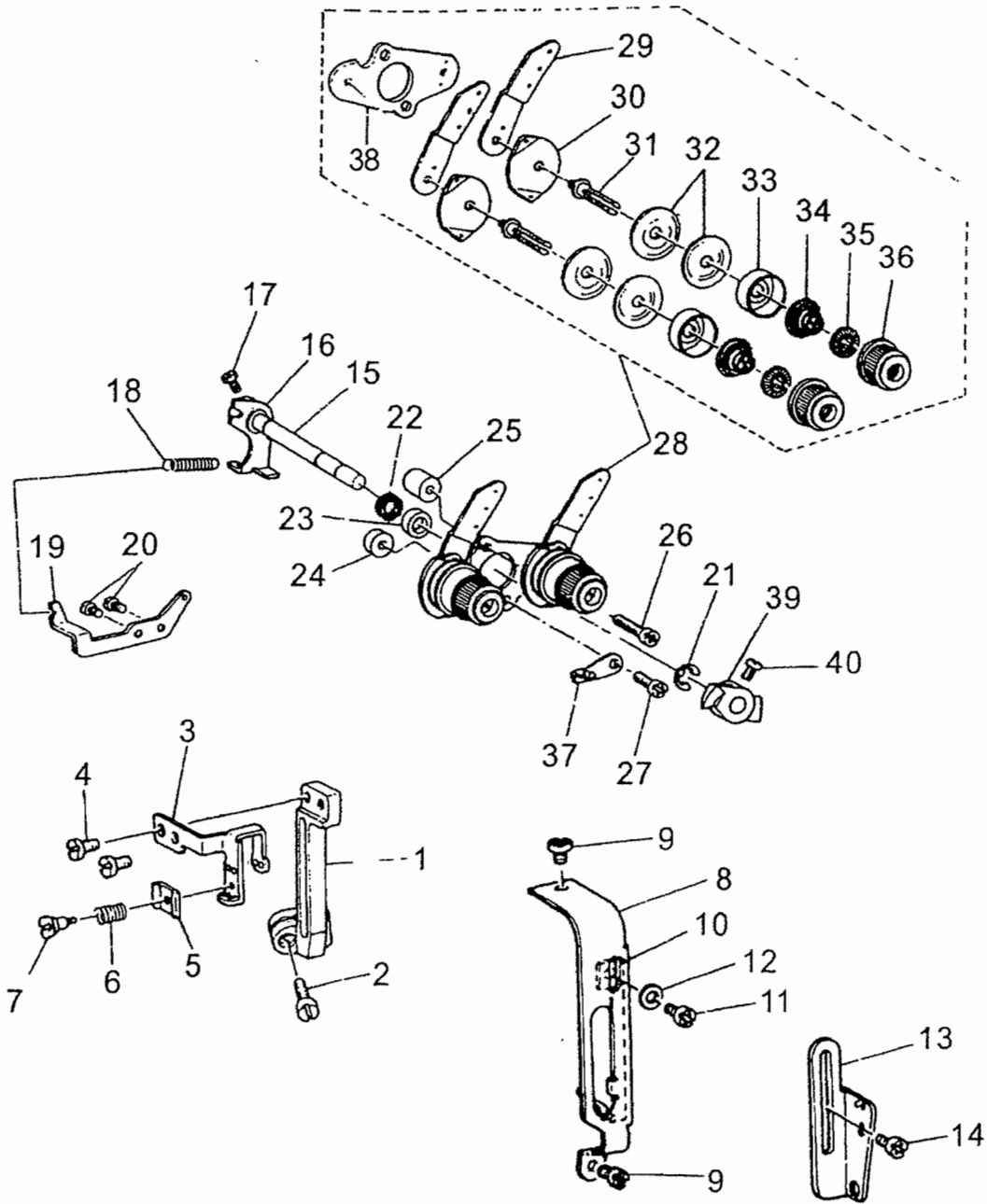

## H. TAKE-UP THREAD TENSION AND RELEASE MECHANISM (1)

Fig. No.	Part No.	Description	Pcs.	Notes
H01	GH390	Thread take-up lever link	1	
H02	GS0140	Screw	1	
H03	GH392	Thread take-up lever	1	
H04	GS011	Set screw	2	
H05	GR1861	Thread tension disc	1	
H06	GW294	Thread tension spring	1	
H07	GS0141	Screw	1	
H08	GK190-1	Thread take-up lever guard	1	
H09	GS010	Screw	2	
H10	GR1862	Thread adjusting disc	1	
H11	GS010	Screw	1	
H12	GR1528	Washer	1	
H13	GR1863	Thread guide hook	1	
H14	GS010	Screw	1	
H15	GZ313	Thread releasing shaft	1	
H16	GH393/2	Needle thread releasing crank	1	
H17	GS082	Screw	1	
H18	GW295	Spring	1	
H19	GR1865	Bracket	1	
H20	GS81	Screw	2	
H21	GR1507	Thread releasing shaft collar	1	
H22	GR1866	Oil seal	1	
H23	GR1867	Thread releasing shaft ring	1	
H24	GR1868	Thread tension regulator mat(upper)	1	
H25	GR1869	Thread tension regulator mat(lower)	1	
H26	GS0142	Screw	1	
H27	GS079	Screw	1	
H28	GR1870/19	Needle thread tension	1	
H29	GR1871	Needle thread guide plate(single side)	2	
H30	GR1872	Needle thread guide plate(double side)	2	
H31	GS0143	Thread tension screw	2	
H32	GR1488	Needle thread tension plate	4	
H33	GR1873	Needle thread tension bushing	2	
H34	GW251	Needle thread tension spring	2	
H35	GR1490	Needle thread stop plate	2	
H36	GL34/2	Needle thread tension nut	2	
H37	GR1875	Thread guide hook	2	
H38	GR1892	Thread tension bracket	1	
H39	GR1876	Needle thread releasing claw	1	
H40	GS082	Screw	2	



# H. TAKE-UP THREAD TENSION AND RELEASE MECHANISM (2)

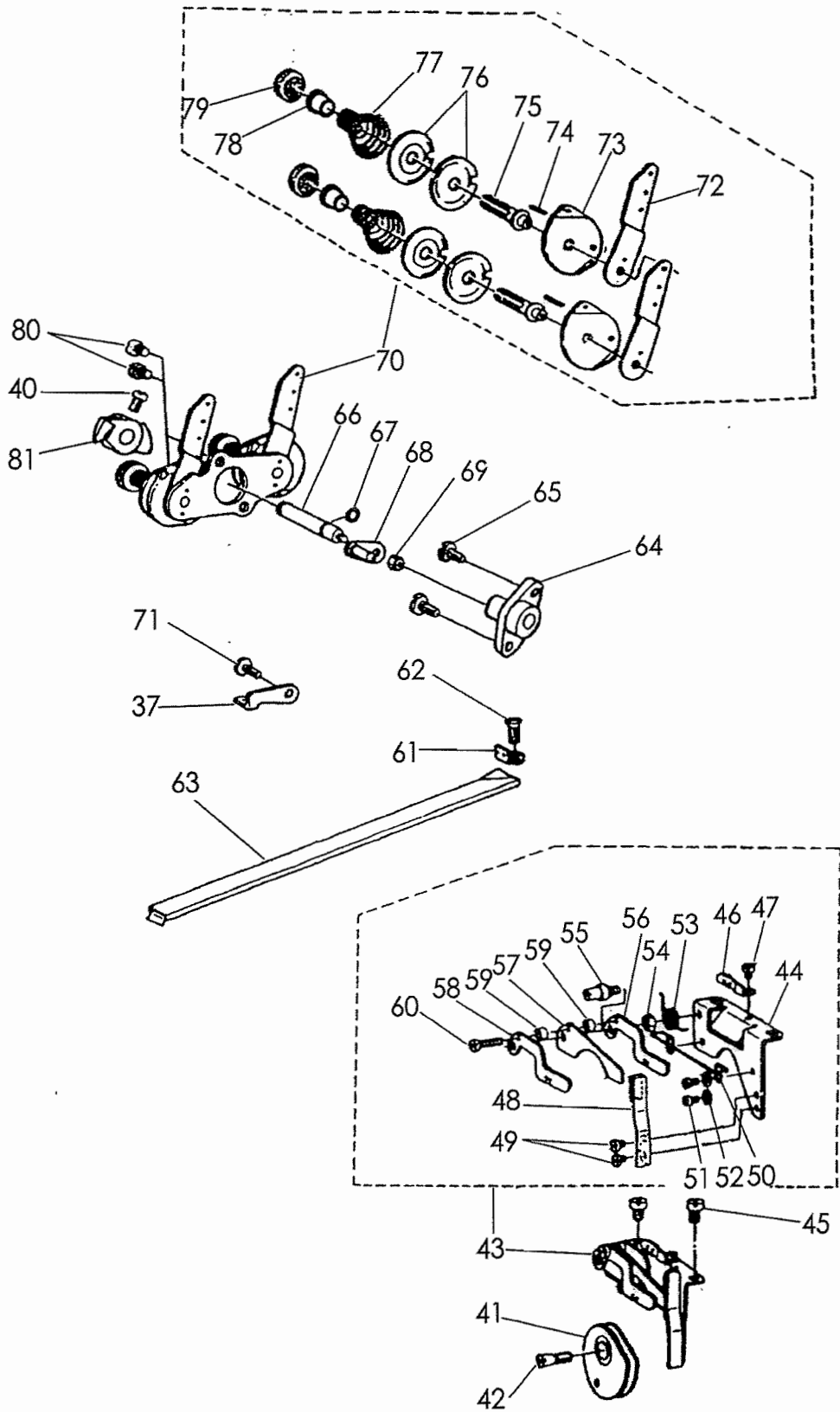

## H. TAKE-UP THREAD TENSION AND RELEASE MECHANISM (2)

Fig. No.	Part No.	Description	Pcs.	Notes
H41	GR1877	Bobbin thread take-up cam	1	
H42	GS0144	Set screw	1	
H43	GR1878/20	Thread guide hook	1	
H44	GR1879	Thread guide bracket	1	
H45	GS010	Screw	2	
H46	GR1880	Bobbin double-thread guide hook	1	
H47	GS069	Screw	1	
H48	GW296	Bobbin thread guide stop spring	1	
H49	GS069	Screw	2	
H50	GR1881	Bobbin thread take off steel wire	1	
H51	GS44	Screw	2	
H52	GR1882	Washer	2	
H53	GW297	Bobbin thread guide spring	1	
H54	GL31	Nut	1	
H55	GS0145	Screw	1	
H56	GR1883	Thread guide hook(right)	1	
H57	GR1884	Thread slippage claw	1	
H58	GR1885	Thread guide hook(left)	1	
H59	GR1886	Thread guide loop	2	
H60	GS065	Screw	1	
H61	GR1887	Bobbin thread guide hook	1	
H62	GS0146	Screw	1	
H63	GR1888	Bobbin thread guide tube	1	
H64	GR1889	Thread releasing shaft bushing	1	
H65	GS0150	Screw	2	
H66	GZ314	Bobbin thread releasing shaft	1	
H67	GR1503	O-type ring	1	
H68	GH395/2	Bobbin thread releasing shaft crank	1	
H69	GL31	Bobbin thread releasing shaft nut	1	
H70	GR1891/19	Bobbin thread tension regulator	1	
H71	GS010	Screw	1	
H72	GR1893	Bobbin thread guide plate(single side)	2	
H73	GR1894	Bobbin thread guide plate(double side)	2	
H74	GX382	Bobbin thread tension stop pin	2	
H75	GS0143	Thread tension nut	2	
H76	GR1895	Bobbin thread tension plate	4	
H77	GW298	Bobbin thread tension spring	2	
H78	GR1896	Bobbin thread tension stop ring	2	
H79	GL36	Bobbin thread tension nut	2	
H80	GS81	Screw	2	
H81	GR1897	Bobbin thread releasing claw	1	

I. LUBRICATION MECHANSISM

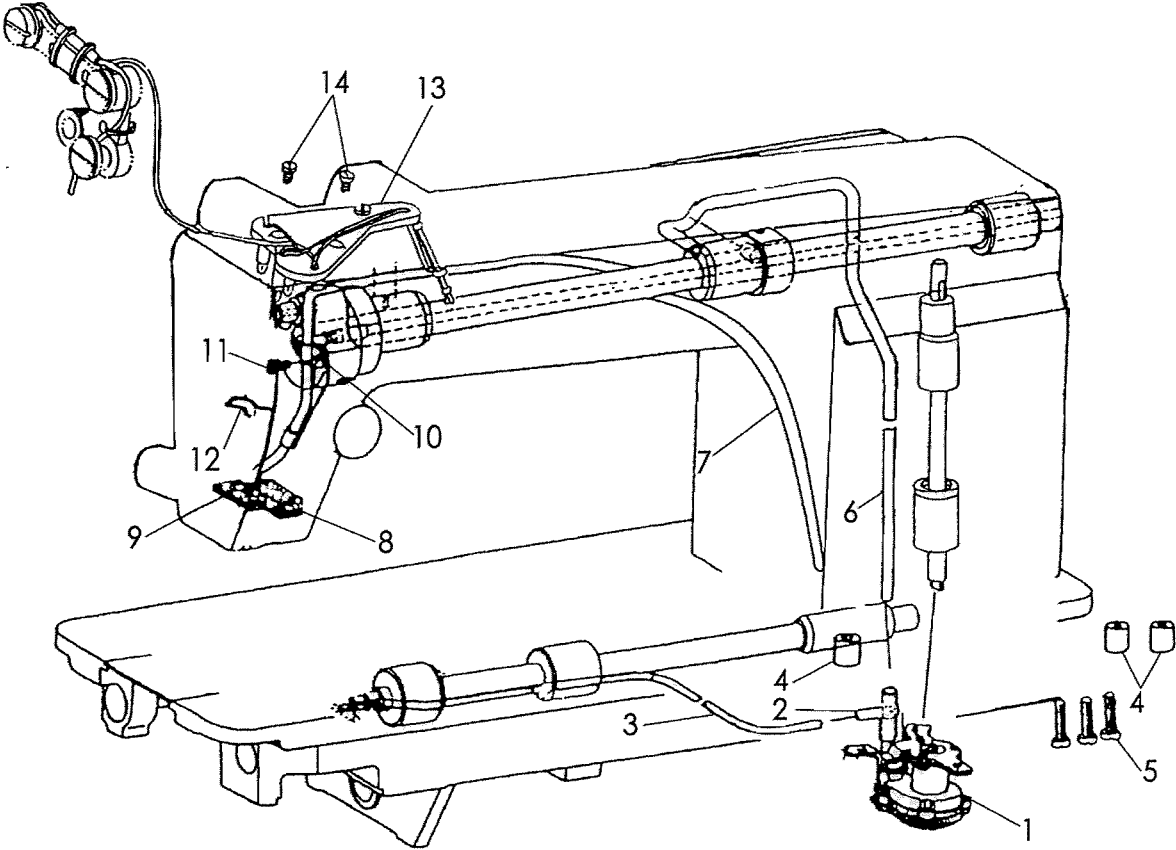

# I. LUBRICATION MECHAINS

Fig. No.	Part No.	Description	Pcs.	Notes
I01	GR1899/21-1	Oil pump complete	1	
I02	GR1903	Rubber joint for oil supply pipe	1	
I03	GR1909	Oil pipe for hook shaft	1	
I04	GR1901	Washer for oil pump	3	
I05	GS0109	Screw	3	
I06	GR1902	Oil pipe for arm shaft	1	
I07	GR1565/4	Oil return pipe	1	
I08	GR1567	Felt	1	
I09	GR1568	Felt	1	
I10	GR1566	Oil pipe clip	1	
I11	GS010	Screw	1	
I12	GR1569	Felt holder	1	
I13	HA100I2010	Oil braid fitting plate	1	
I14	HA100I2120	Screw	2	

# J. OIL PAN AND KNEE CONTROL MECHANISM

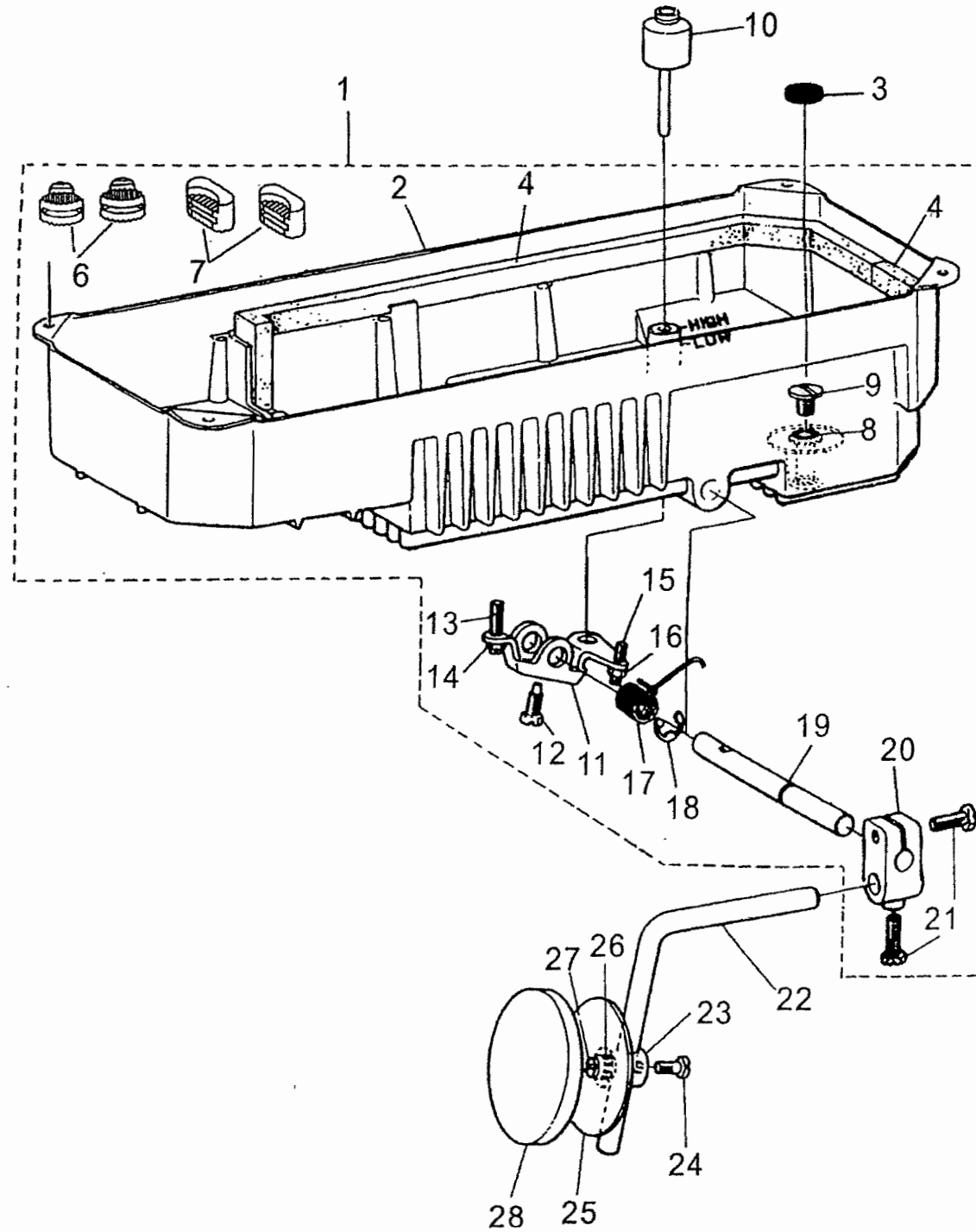

## J. OIL PAN AND KNEE CONTROL MECHANISM

Fig. No.	Part No.	Description	Pcs.	Notes
J01	GR1910/16	Oil pan complete	1	
J02	GR1911	Oil pan	1	
J03	GR1576	Oil magnet	1	
J04	GR1912	Gasket for oil pan	1	
J06	GR3408	Rubber cushion(small)	2	
J07	GR1578-D	Rubber cushion(big)	2	
J08	GR3409	Oil drain screw washer	1	
J09	GS02	Oil drain screw	1	
J10	GR1581	Knee lifter lifting rod	1	
J11	GR1582	Knee lifter stop bracket	1	
J12	GS056	Screw	1	
J13	GS057	Adjustment bolt	1	
J14	GL21	Lock nut	1	
J15	GS058	Adjustment bolt	1	
J16	GL21	Lock nut	1	
J17	GW261	Spring	1	
J18	GR1583	E ring	1	
J19	GZ283	Shaft for knee lifter	1	
J20	GR3410	Joint for knee lifter	1	
J21	GS0292	Screw	2	
J22	GR33411/6	Knee lifter rod	1	
J23	GR1587	Joint for knee lifter rod	1	
J24	GS08	Screw	1	
J25	GR1588	Knee lifter plate	1	
J26	GW262	Spring	1	
J27	GS060	Screw for knee lifter plate	1	
J28	GKR13	Pad for knee lifter plate	1	

K. ACCESSORIES

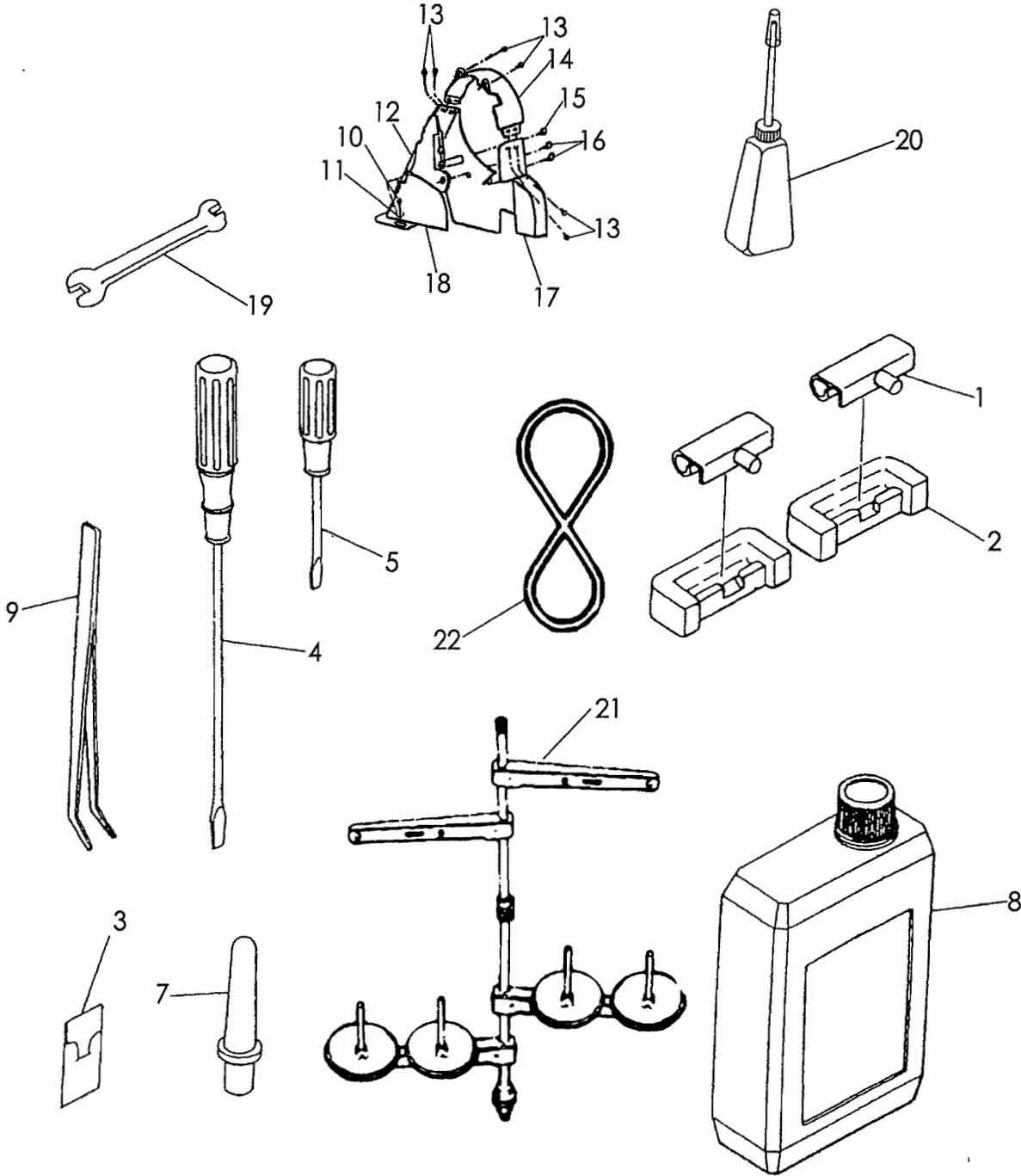

## K. ACCESSORIES

Fig. No.	Part No.	Description	GK0318-1	GK0318-2	GK0318-3	Notes
K01	GR1590/2	Bed hinge	2	2	2	
K02	GR1593	Rubber socket for hinge	2	2	2	
K03	GV18	Needle	3	3	3	TV×5
K04	GR1601	Screw drive (large)	1	1	1	
K05	GR1602	Screw drive (middle)	1	1	1	
K07	GBR148	Head support	1	1	1	
K08	GR1604/3	Oil container	1	1	1	
K09	GR558/2	Tweezer	1	1	1	
K10	GBS120-1	Screw	2	2	2	
K11	GBR147	Washer	2	2	2	
K12	H200800068	Belt cover (upper)	1	1	1	
K13	HA300B2170	Screw	6	6	6	
K14	H200800671	Belt mark complete	1	1	1	
K15	HA300J2250	Screw	1	1	1	
K16	HA300J2280	Screw	2	2	2	
K17	H200800067	Belt cover (lower)	1	1	1	
K18	HA305J0665	Belt cover complete	1	1	1	
K19	HA300J2220	Double head wrench	1	1	1	
K20	GR1799	Oiler	1	1	1	
K21	GR3420	Thread stand	1			
K21	GR1932/30	Thread stand		1		
K21	GR1932/38	Thread stand			1	
K22		Belt	1	1	1	M40



L. SPECIAL PARTS FOR 2097-1

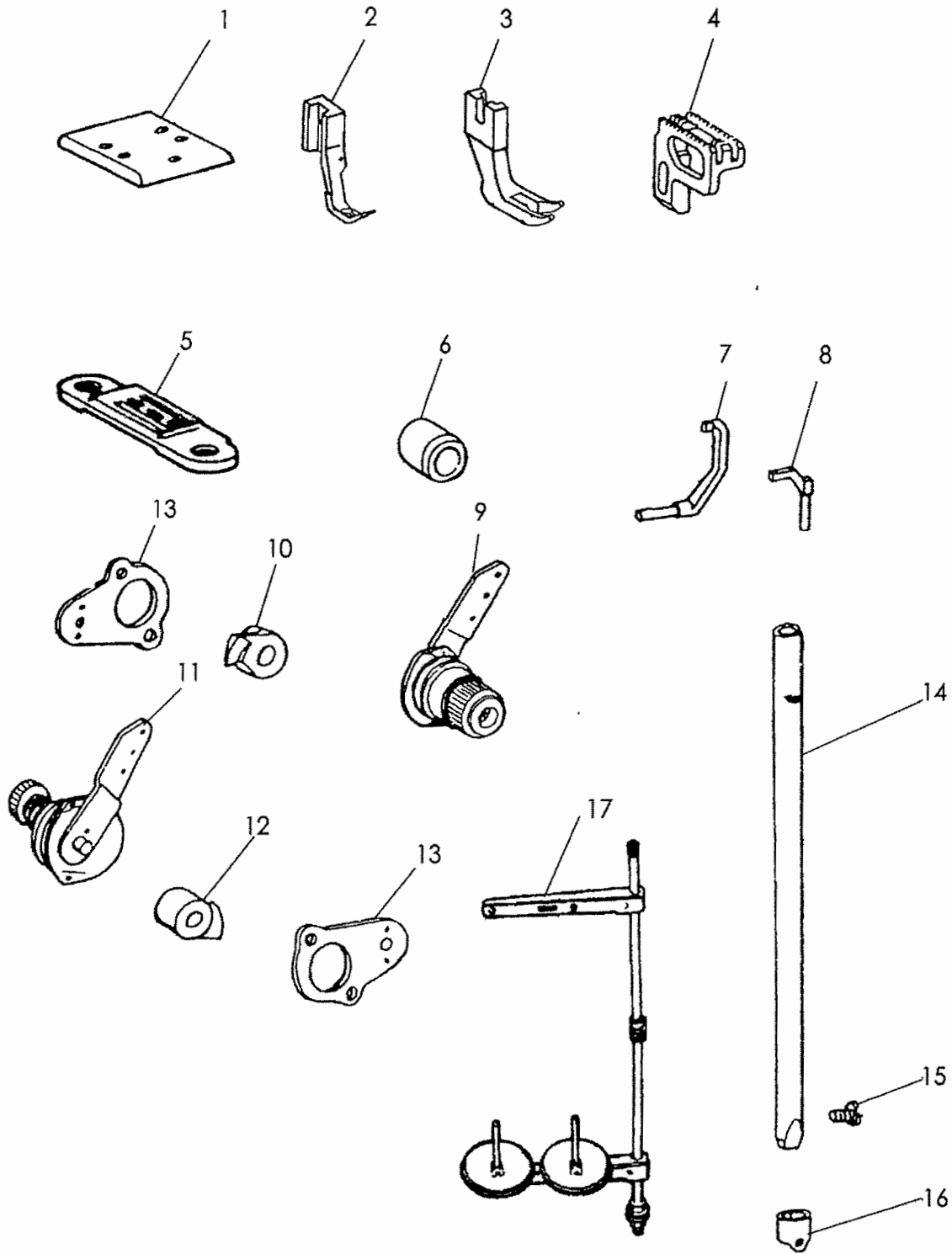

# L. SPECIAL PARTS FOR 2097-1

Fig. No.	Part No.	Description	Pcs.	Notes
L01	GM274	Bracket	1	
L02	7WF3-003(11WF3-001)	Presser foot	1	
L03	7WF5-006	Walking foot	1	
L04	GM276	Feed dog	1	
L05	GM277	Needle plate	1	
L06	GR1998	Looper crank collar	1	
L07	GR1999	Needle guard sway bar	1	
L08	GR2000	Needle guard fix bar	1	
L09	GR2001/9	Needle thread tension complete	1	
L10	GR2002	Needle thread relaxation crank	1	
L11	GR2003/11	Bobbin thread tension complete	1	
L12	GR2005	Bobbin thread relaxation crank	1	
L13	GR2004	Bracket	2	
L14	GZ318	Needle bar	1	
L15	GS071	Screw	1	
L16	GR1481	Needle bar thread guide	1	
L17	GR3420	Thread stand	1	

M. SPECIAL PARTS FOR 2097-3



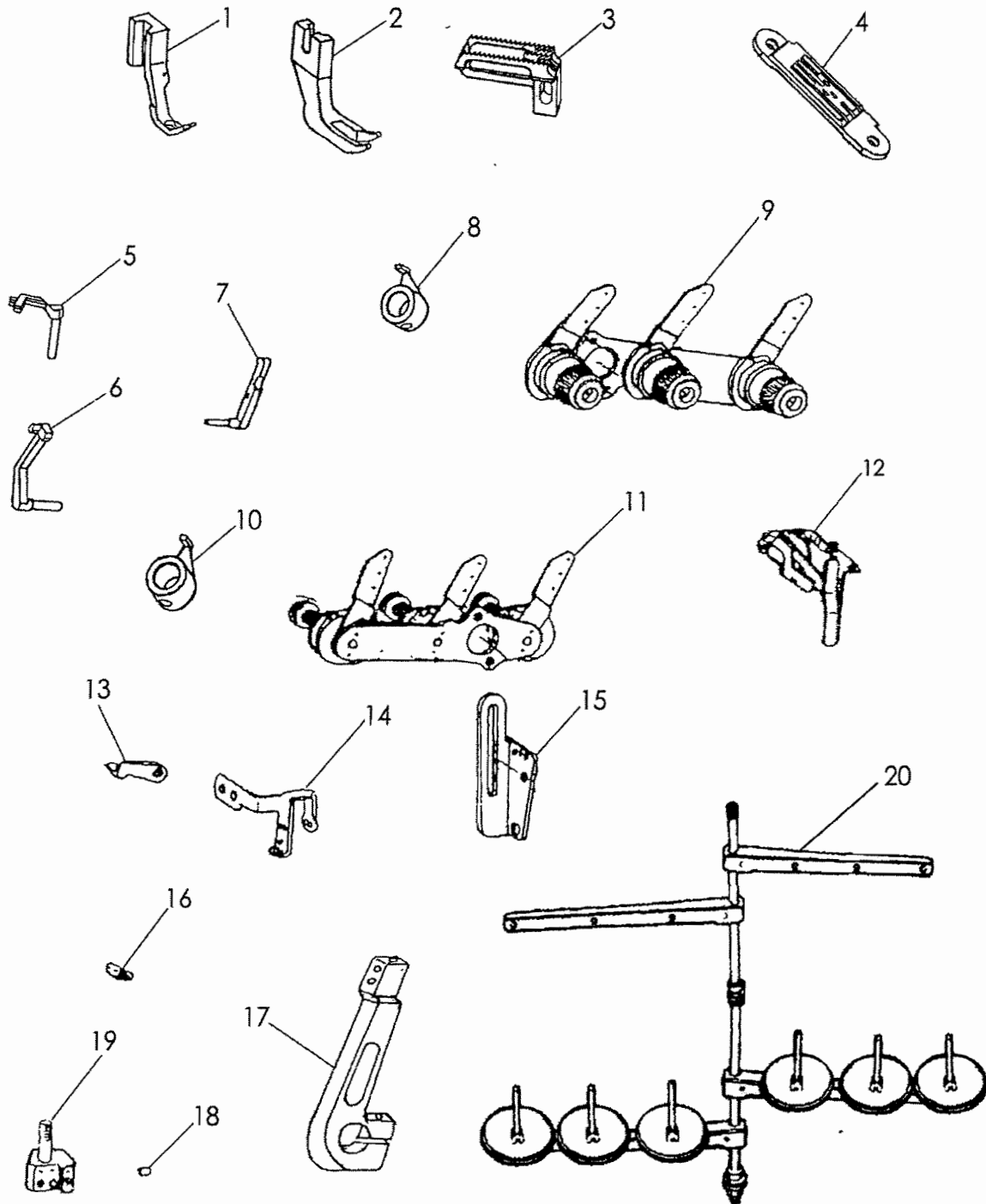





---

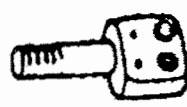
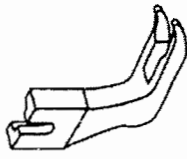
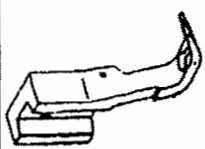

M. SPECIAL PARTS FOR 2097-3

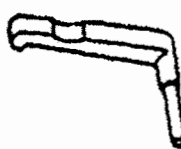
Fig No.	Part No.	Description	Pcs.	Notes
M01	GM323	Presser foot	1	3.2-3.2
M02	GM328	Walking foot	1	3.2-3.2
M03	GM247-3	Feed dog	1	3.2-3.2
M04	GM248-3	Needle plate	1	3.2-3.2
M05	GR1857-3	Lopper guard swing bar	1	3.2-3.2
M06	GR1859-3	Lopper guard fix bar(left)	1	
M07	GR1860-3	Lopper guard fix bar(right)	1	
M08	GR1876-3	Needle thread relaxation crank	1	
M09	GR1870-3	Needle thread tension complete	1	
M10	GR1897-3	Bobbin thread relaxation crank	1	
M11	GR1891-3	Bobbin thread tension complete	1	
M12	GR1878-3	Thread guide cam complete	1	
M13	GR1875-3	Thread guide	2	
M14	GH392-3	Thread take-up lever	1	
M15	GR1863-3	Thread guide	1	
M16	GR1887-3	Bobbin thread guide	1	
M17	GR386-3A	Looper crank A	1	
M17	GR386-3B	Looper crank B	1	
M17	GR386-3C	Looper crank C	1	
M18	GS0138-3	Screw	6	
M19	GR1826-3	Needle clamp	1	3.2-3.2
M20	GR1932/38	Thread stand	1	

Parts for Optional Needle Spacing

DEFINITION	NEEDLE PLATE	NEEDLE CLAMP	WALKING FOOT	PRESSER FOOT	LOOPER (LEFT)	LOOPER (RIGHT)									
 MODEL 1/4" (6.4mm) 5/16" (7.9mm) 3/8" (9.5mm) 1/2" (12.7mm) 1/8" (3.2-3.2mm) 1/4" (6.4-6.4mm)	 GR1826 GR1958 GR1966 GR1973 GR1826-3 GR1973-3	 GM328 GM348 GM368 GM388 GM328 GM388	 GM322 GM342 GM352 GM362 GM323 GM363	 GN169 2097-3 (2 Loopers)	 GN170										
						LOOPER GUARD BAR LOOPER GUARD FIX BAR (RIGHT)	LOOPER GUARD FIX BAR (LEFT)	SLIDE PLATE CAM COVER	FEED DOG						
						 MODEL 1/4" (6.4mm) 5/16" (7.9mm) 3/8" (9.5mm) 1/2" (12.7mm) 1/8" (3.2-3.2mm) 1/4" (6.4-6.4mm)	 GR1860 GR1860-3	 GR1859 GR1859-3	 GM245 GM269 GM245 GM269	 GM243 GM262 GM270 GM243 GM270	 GM247 GM261 GM265 GM268 GM247-3 GM268-3				
												LOOPER GUARD BAR LOOPER GUARD FIX BAR (RIGHT)	LOOPER GUARD FIX BAR (LEFT)	SLIDE PLATE CAM COVER	FEED DOG
												LOOPER GUARD BAR LOOPER GUARD FIX BAR (RIGHT)	LOOPER GUARD FIX BAR (LEFT)	SLIDE PLATE CAM COVER	FEED DOG
												LOOPER GUARD BAR LOOPER GUARD FIX BAR (RIGHT)	LOOPER GUARD FIX BAR (LEFT)	SLIDE PLATE CAM COVER	FEED DOG
												LOOPER GUARD BAR LOOPER GUARD FIX BAR (RIGHT)	LOOPER GUARD FIX BAR (LEFT)	SLIDE PLATE CAM COVER	FEED DOG
LOOPER GUARD BAR LOOPER GUARD FIX BAR (RIGHT)	LOOPER GUARD FIX BAR (LEFT)	SLIDE PLATE CAM COVER	FEED DOG												
LOOPER GUARD BAR LOOPER GUARD FIX BAR (RIGHT)	LOOPER GUARD FIX BAR (LEFT)	SLIDE PLATE CAM COVER	FEED DOG												